

1. Mechanical Dimensions:

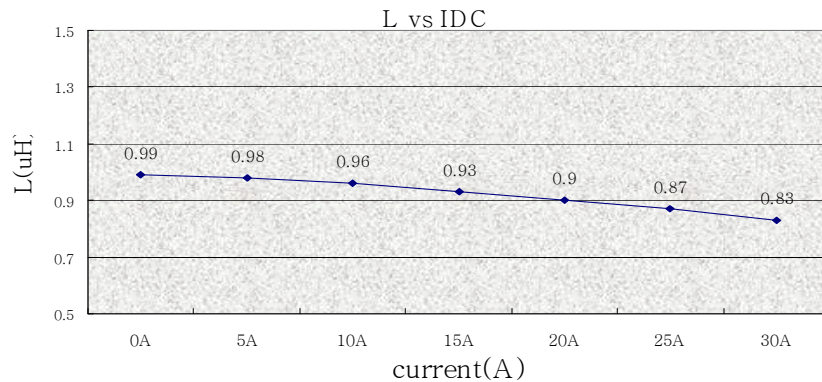

2. Schematic:

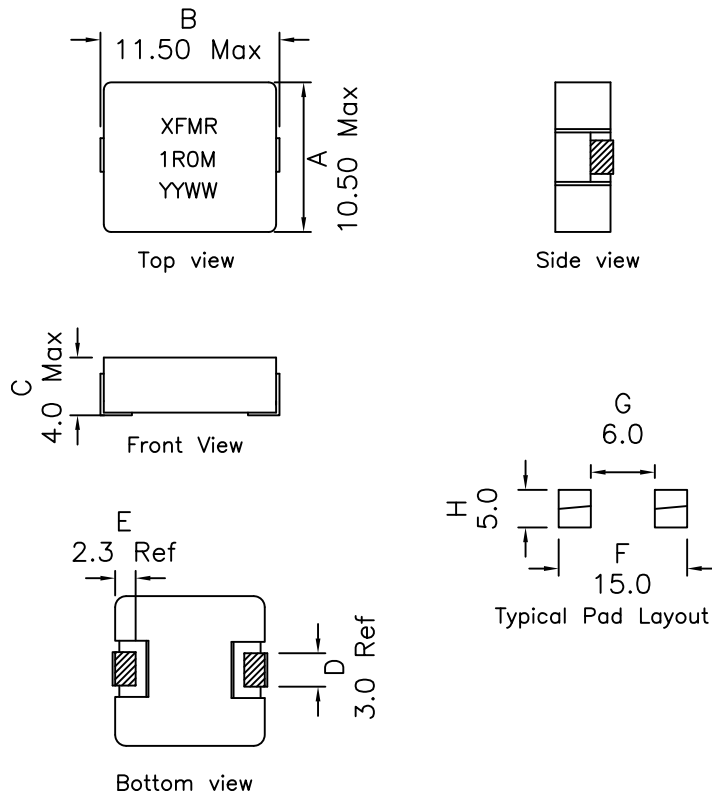
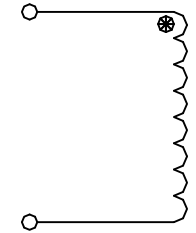

3. Electrical Specifications: @25°C

OCL: 1.0uH±20% @100KHz, 0.1V

Q: 23 Min @100KHz, 0.1V

DCR: 4.1 mOhms Max

Isat: 36.0 A (Based on 20% drop in OCL)

Rated Current: 17.5A (Based on 40°C Temp Rise)

SRF: 20MHz Min

Notes:

- Solderability: Leads shall meet MIL-STD-202G, Method 208H for solderability.
- Flammability: UL94V-0
- ASTM oxygen index: > 28%
- Insulation System: Class F 155°C. UL file E151556
- Operating Temperature: -40°C to +85°C
- Storage Temperature Range: -55°C to +125°C
- Aqueous wash compatible
- SMD Lead Coplanarity: 0.004"(0.102mm) Max
- Electrical and mechanical specifications 100% tested
- RoHS Compliant Component
- Outsourced item processed & controlled under XFMRs QA system
- Recommended IR Reflow peak temp of 260°C Max.

XFMRs Inc www.XFMRs.com	Title: XFHCL11 SERIES INDUCTORS		
	UNLESS OTHERWISE SPECIFIED TOLERANCES: .xxx ±0.010 Dimensions in Inch	P/N: XFHCL11-1ROM DWN. CHK. APP.	Huo YK Liao BSJ
SHEET 1 OF 1			

DOC. REV: A/8

PROPRIETARY

Document is the property of XFMRs Group & is not allowed to be duplicated without authorization.

XFMRs

Recommended Infrared Reflow Temperature Profile for RoHS Compliant Parts

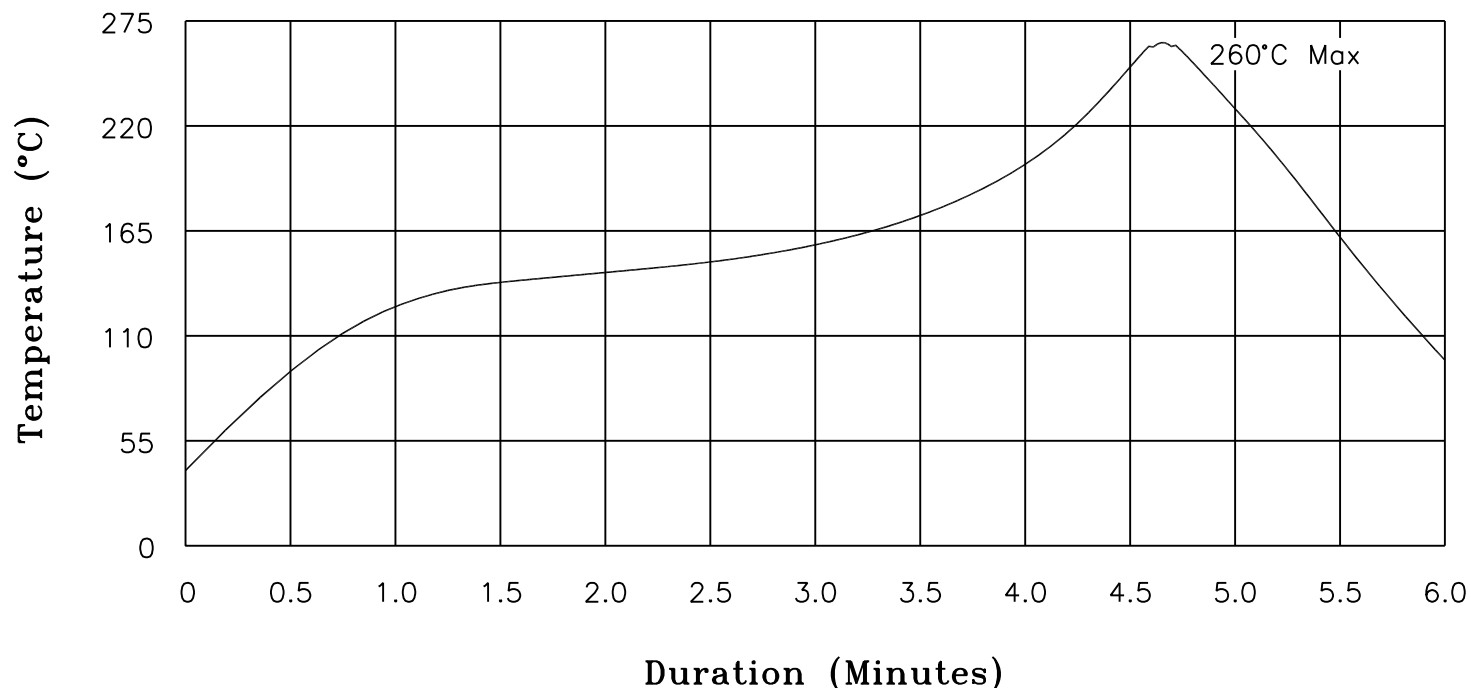

NOTES: Maximum duration at 260°+0/-5° with 10 seconds Max.
 Maximum duration above 217° shall be 60-150 seconds.
 ALL Temperatures refer to topside of the package, measured on the package body surface.

XFMRs Inc www.XFMRs.com	Title: IR REFLOW CHART (RoHS Compliant parts)		
	UNLESS OTHERWISE SPECIFIED TOLERANCES: N/A	P/N: N/A	REV. A
	DWN.	Juan Mao	Jan-16-05
	CHK.	YK Liao	Jan-16-05
SHEET 1 OF 1	APP.	MS	Jan-16-05

PROPRIETARY Document is the property of XFMRs Group & is not allowed to be duplicated without authorization.

TAPE AND REEL SPECIFICATION:

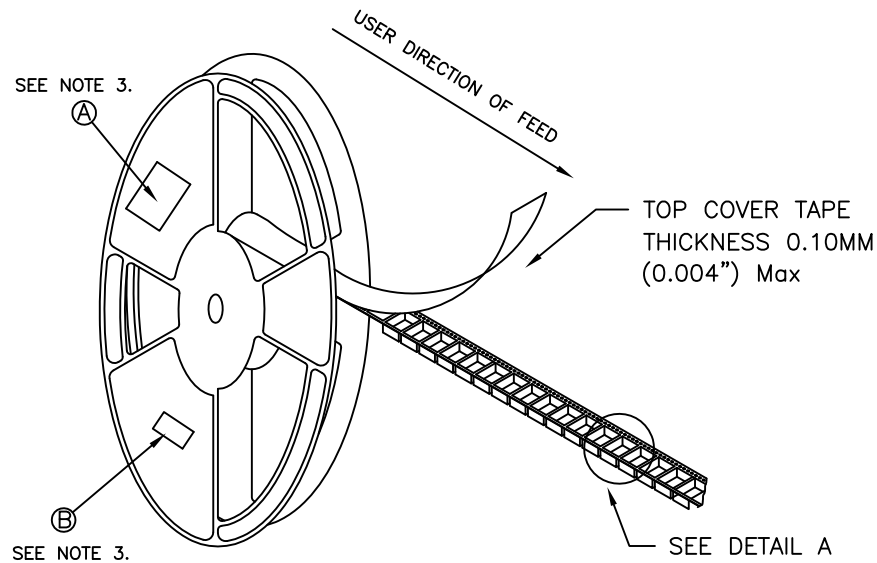

REEL AND TAPE ORIENTATION

13" REEL DIAMETER

FOR ALL XFHCL11-XXXX SERIES

NOTES:

- 1) PROCESS IN ACCORDANCE WITH EIA-481-2 STANDARDS
 - * TAPE LEADER DIMENSION 15.30" MIN.
 - * TAPE TRAILER DIMENSION 6.30" MIN.
- 2) PARTS SHOULD BE PACKAGED IN ACCORDANCE WITH ESD GUIDELINES IN EIA-541.
- 3) REEL LABEL: 'A' * PART NUMBER
 - * QUANTITY
 - * DATE CODE
- 4) 500PCS PER 13" REEL

DETAIL A

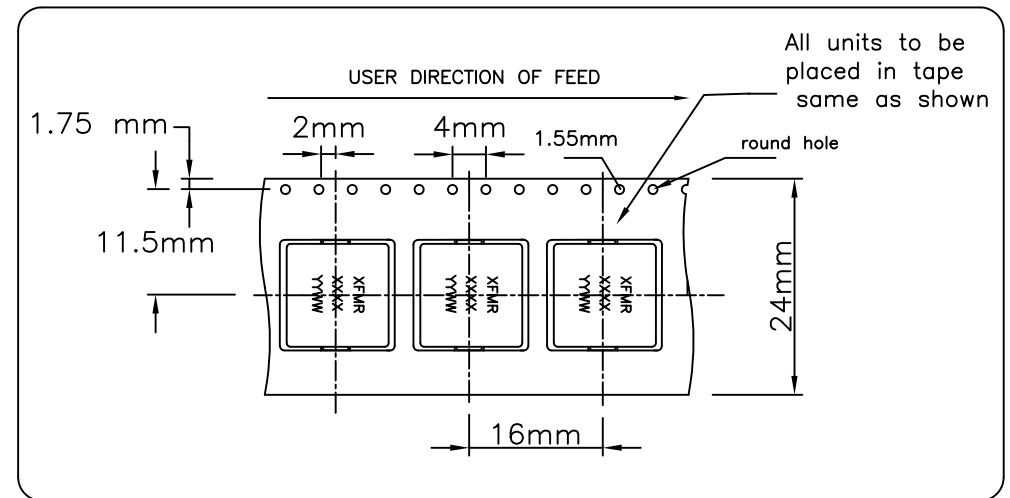

DOC. REV. A/2

XFMR Inc	Title: T&R SPEC		
UNLESS OTHERWISE SPECIFIED	P/N: XFHCL11 series		REV: A
TOLERANCES: .xxs ±xxxxx	DWN.	Kong	Oct-31-17
Dimensions in mm	CHK.	YK Liao	Oct-31-17
SHT 1 OF 1	APP.	GL	Oct-31-17

PROPRIETARY

Document is the property of XFMR Group & is not allowed to be duplicated without authorization.