

10W to 150W Single Output, 115VAC Input

Features

- ◆ Input transient protected
- ◆ 2 year warranty
- ◆ High quality design
- ◆ 200% Peak Power Version (VSP)
- ◆ Broad product range



Key Market Segments & Applications



Industrial



RoHS

Specifications		VS10C	VS15C	VS30C	VS50P	VS75P	VS100P	VS150P
AC Input Voltage range	-	85-132VAC (47-440Hz)						
DC Input Voltage range	VDC	110 - 175VDC						
Inrush Current (100VAC) (1)	A	25	30	25	30	30	20	20
Temperature Coefficient	-	<0.02%/°C						
Overcurrent Protection (2)	-	~105%			VSP: >102% of Peak			
Overvoltage Protection	V	~115% Diode Clamp			~115 - 135% Manual Reset			
Hold Up Time (Typ) at 100VAC	ms	20			17			
Remote Sense	-	None						
Operating Temperature (3)	-	-10°C to +60°C, derate linearly to 70% load from 50°C to 60°C						
Storage Temperature	-	-30 to +85°C						
Humidity (non condensing)	-	Storage 10-95% RH, Operating 30-90% RH						
Cooling (4)	-	Convection						Forced
Withstand Voltage	-	Input to Ground 2kVAC (20mA), Input to Output 2kVAC (20mA), Output to Ground 500VAC (100mA) for 1 min.						
Isolation Resistance	-	>100M at 25°C & 70%RH, Output to Ground 500VDC						
Vibration (non operating)	-	10 - 55Hz (1 minute sweep), 19.6m/s ² constant X, Y, Z 1 hour						
Shock	-	< 196.1 m/s ²						
Safety Agency Approvals	-	UL60950-1, CSA60950-1, EN60950-1						
Conducted & Radiated EMI	-	FCC Class B, VCCI-B						
Recommended EMI Filter	-	RSEL-20R5W	RSEL-2001W		RSEL-2002W	RSEL-2003W	RSEL-2006W	
Weight (Typ) (VSP)	g	65	80	150	200	280	350	480
Size (WxHxD)	mm	See Outline Drawings						
Warranty	yrs	Two Years						

Notes:

- (1) 25°C ambient (cold start)
- (2) Avoid prolonged operation in overload
- (3) VS50P derate to 60% at 60°C
- (4) 0.7m/s forced air required, consult installation manual for derating with convection cooling

VS-P Models Last Time Buy November 2019

VSC30 Outline Drawing

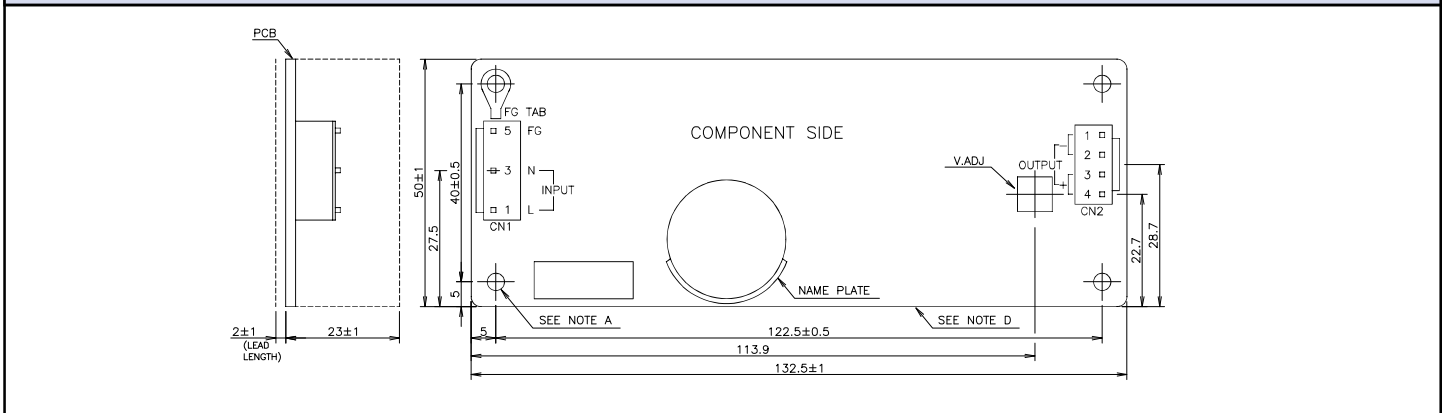

VSP100 Outline Drawing

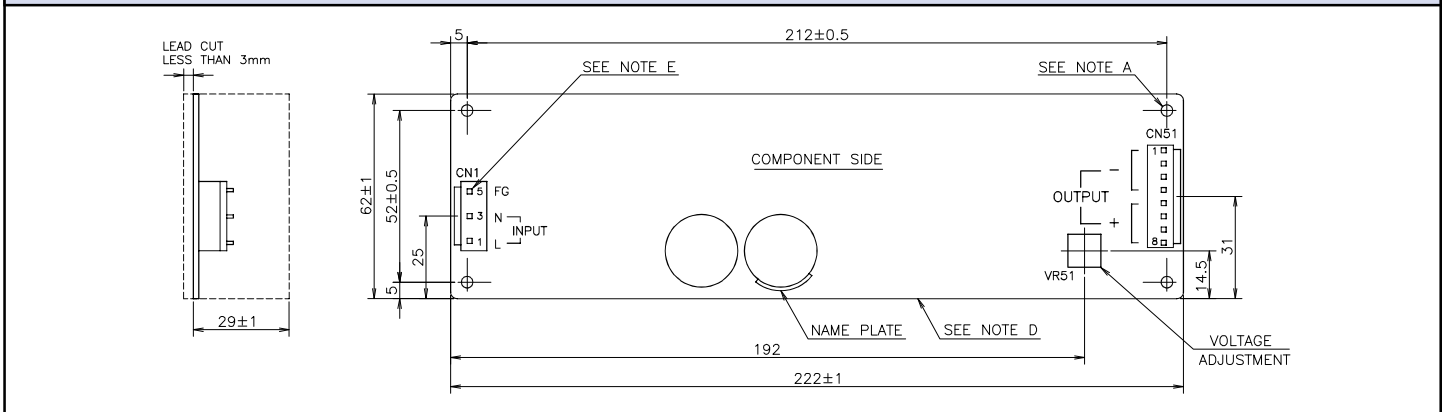

Model Selector

Model	Voltage V	Adjust Range V	Max Curr. A	Peak Curr. A	Load Reg mV	Line Reg mV	Ripple Noise mV	Eff. %
VS10C-3	3.3	2.97-3.63	2	-	40	20	120	62
VS15C-3	3.3	2.97-3.63	3	-	40	20	120	62
VS30C-3	3.3	2.97-3.63	6	-	40	20	120	69
VS10C-5	5	4.5-5.5	2	-	40	20	120	71
VS15C-5	5	4.5-5.5	3	-	40	20	120	72
VS30C-5	5	4.5-5.5	6	-	40	20	120	75
VS10C-12	12	10.8-13.2	0.9	-	96	48	150	75
VS15C-12	12	10.8-13.2	1.3	-	96	48	150	75
VS30C-12	12	10.8-13.2	2.5	-	96	48	150	80
VS10C-15	15	13.5-16.5	0.7	-	120	60	150	75
VS15C-15	15	13.5-16.5	1	-	120	60	150	75
VS30C-15	15	13.5-16.5	2	-	120	60	150	81
VS10C-24	24	21.6-26.4	0.5	-	240	96	200	78
VS15C-24	24	21.6-26.4	0.7	-	240	96	200	78
VS30C-24	24	21.6-26.4	1.3	-	150	96	200	82
VS50P-24	24	21.6-26.4	2.5	4.2	150	96	180	83
VS75P-24	24	21.6-26.4	3.2	7.0	150	96	180	83
VS100P-24	24	21.6-26.4	4.3	10	150	96	180	85
VS150P-24	24	21.6-26.4	6.3	12	150	96	180	86
VS30C-36	36	32.4-39.6	0.9	-	240	144	300	80
VS30C-48	48	43.2-52.8	0.7	-	480	192	400	80

Peak Current Note: For 10s maximum, 35% duty cycle, average power not to exceed maximum ratings. See installation manual.

Other Industrial Products

HWS	15W to 1500W Single output
ZWS, ZWD, ZWQ	5W to 240W Universal input
SC, SCS120	30W to 120W Single, dual & triple output
ZP	40W to 60W Single & multiple output

For Additional Information, please visit us.tdk-lambda.com/lp/products/vsb-series.htm



VS-P Models Last Time Buy November 2019