

CC3060 TYPE 12 COMPACT CABINET COOLER AIR-TO-WATER FLUSH-MOUNT MODEL

Model	Weight	Rating @ 40°C ΔT BTU / hr	Amps Current Draw at 115 volts AC	Fan Size	Dimensions-Inches (H x W x D)
CC3060	13 lbs	9,300	0.3	1 x 6"	30 x 8-3/4 x 4

Efficiency: 68.8 Watts / °C ΔT based on average internal cabinet temperature.

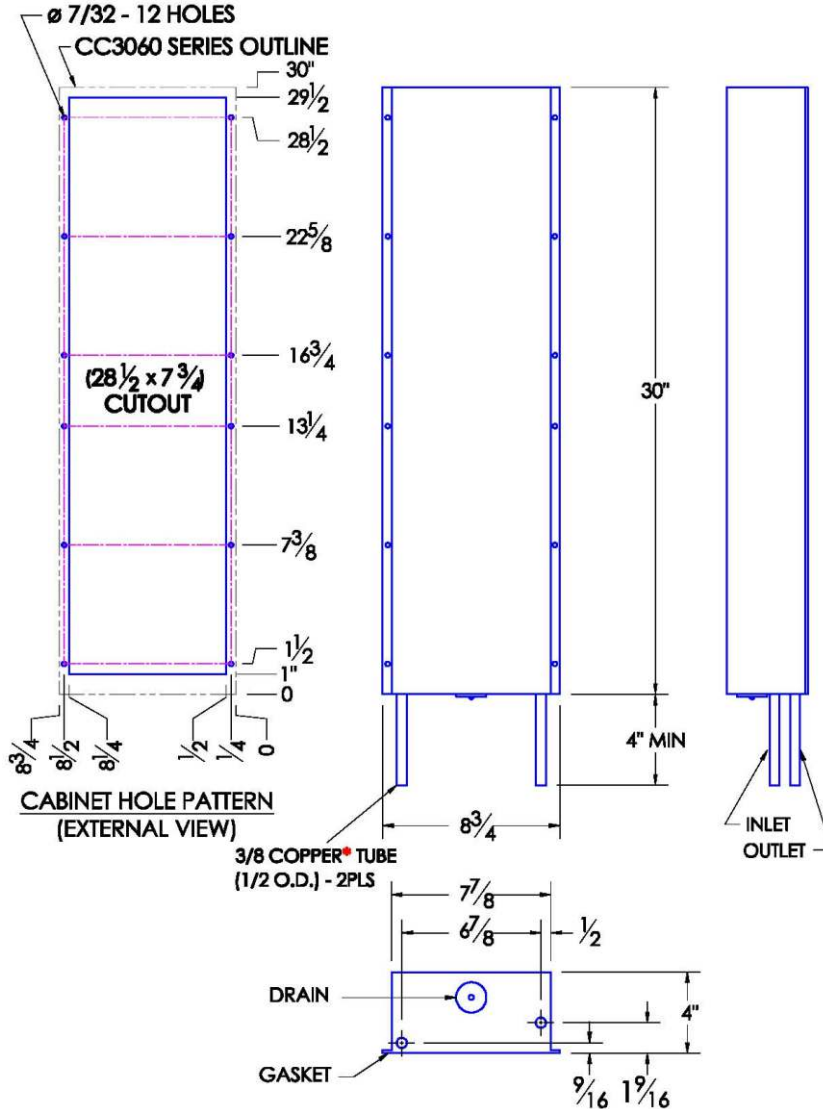

Outside View



Inside View

SPECIFICATIONS

1. UL Listed for TYPE 12 environments.
2. CC3060 Rated cooling: 2,725 Watts mounted to an uninsulated 72" x 36" x 24" Cabinet with 1 GPM of water at 20°C, 40°C ambient air and 60°C cabinet air temperature.
3. Designed for surface mounting on the outside of cabinet.
4. Housing is aluminum (color is black).
5. External water inlet and outlet connections.
6. Equipped with mounting gasket to maintain air tight seal.
7. Available with AC (115 & 230V) and DC (12, 24, & 48V) fans. DC version includes junction box, consult website.
8. Vertical mounting only.
9. Coolant water pressure: Pressure tested to 100 psi. Safe working pressure is 60 psi.
10. Recommended coolant flow rate (gallons per minute): 1 GPM
11. **For design, quote, and sizing assistance: call (866) 936 - 6736.**

Subject to change without notice.



UL File #SA9567



Proudly made in USA



ISO 9001:2008
FM 554949

NOREN

1010 O'Brien Drive
Menlo Park, CA 94025
650.322.9500
norenproducts.com

CC3060 TYPE 12

CCS-PBD-7.2.2-883343-B