

IMPEDANCE (Z)			
Frequency	25 MHz	100 MHz	300 MHz
Nominal (REF)	126 Ω	240 Ω	362 Ω
Minimum	- Ω	192 Ω	- Ω

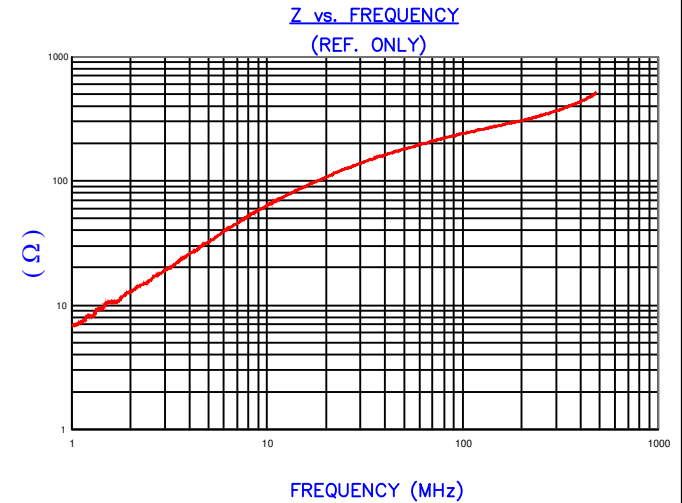

AGILENT E4991A Impedance/Material Analyzer
HP 16092A Test Fixture,

RoHS

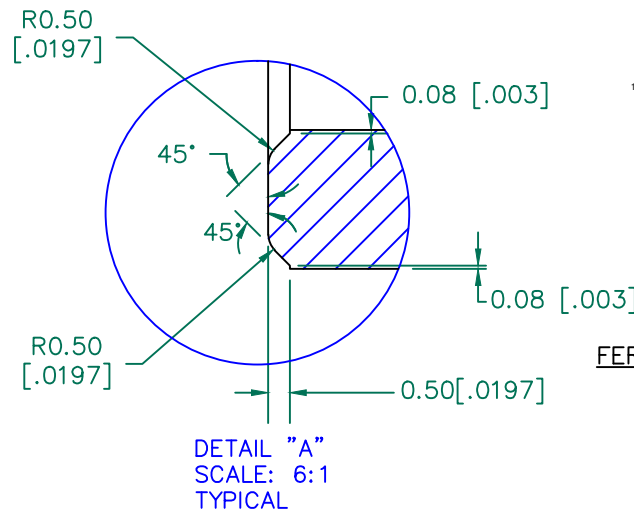

FERRITE CORE DIMENSIONS (SPEC):mm [Inches]

A	12.00 [.472]	+	0.30 [.012]
B	5.60 [.220]	+	0.30 [.012]
C	25.00 [.984]	+	0.50 [.020]

WEIGHT/1000: 10.80 kgs 23.81 Lbs.

NOTES: UNLESS OTHERWISE SPECIFIED

1. COSMETIC SPECIFICATION REFER TO WI-QA-038.

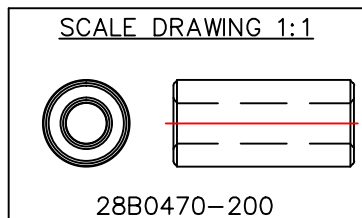

DIMENSIONS ARE IN mm [INCHES].				This print is the property of Laird Tech. and is loaned in confidence subject to return upon request and with the understanding that no copies shall be made without the written consent of Laird Tech. All rights to design or invention are reserved.			
PROJECT/PART NUMBER:	REV	PART TYPE:	DRAWN BY:				
		28B0470-200	A	FERRITE CORE	Jcai		
		DATE: 05/07/2018		SCALE: 2.5:1			
A	NEW RELEASE	05/07/2018	Jcai	CAD #			
REV	DESCRIPTION	DATE	INT	28B0470-200-A	TOOL #	B0470	MATERIAL: Ferrite