

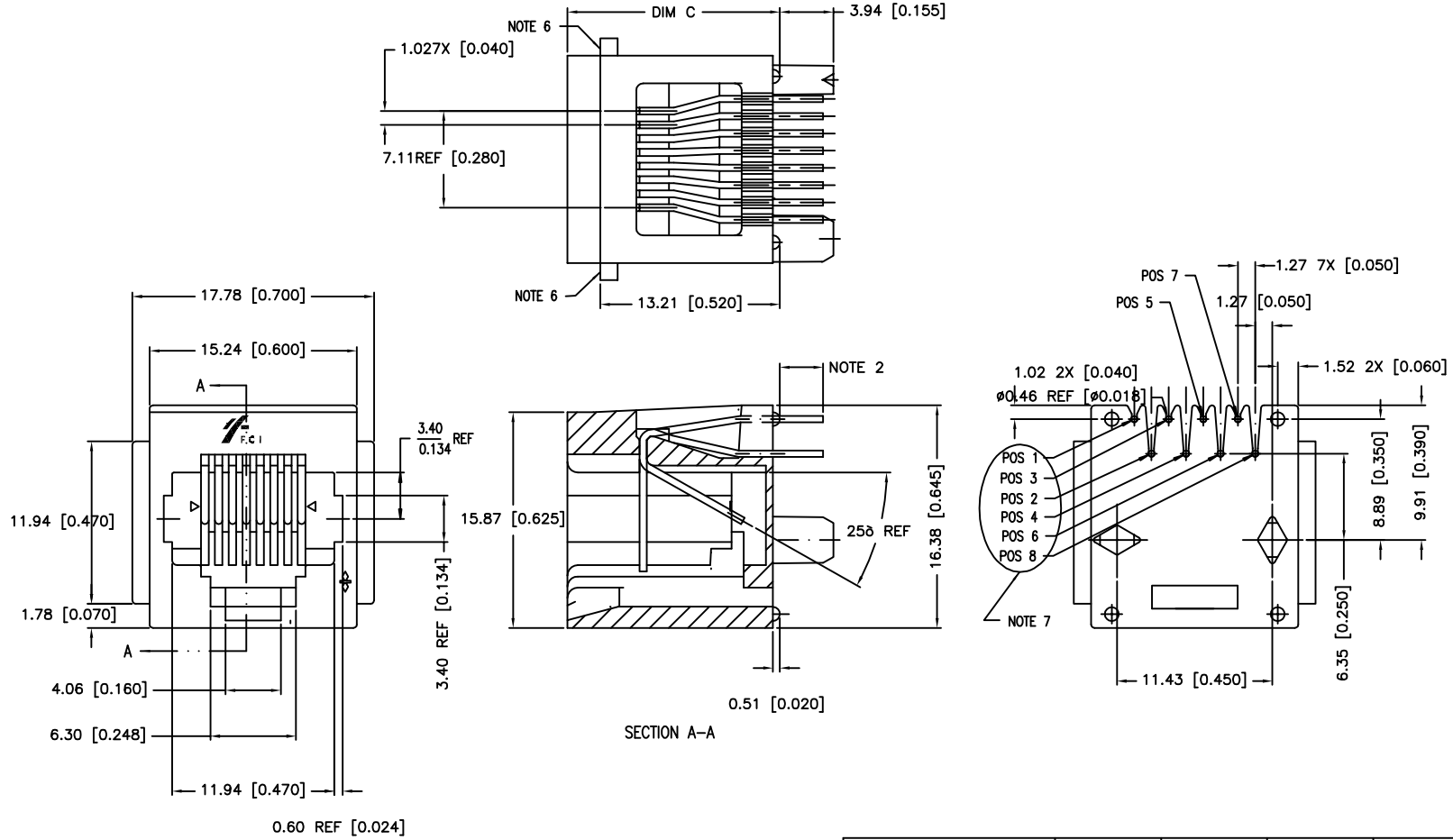

PRODUCT NO.
SEE TABLE



A

A

B

B

mat'l. code				surface ISO1302 ✓		tolerance ISO1101 ISO406		projection 		product family MOD JACK			
lfr ecn no dr date				tolerances unless otherwise specified						title			
AJ ELX-N-15334 Henry 07/18/13				angles		0.X±0.3		mm		8 POS VERTICAL			
- - - - -				0°±2'		0.XX±0.15				PC.B. MOD JACK ASSY			
AD N08-0239 MHT 11/10/08				0°±2'		0.XXX±0.05		scale 2.0		dwg no sheet, 1 of 3 size			
AE N09-0092 SH MNO 01/13/10				dr		JANET 2/22/00				69255 A4			
AF ELX-N-010675 SH MNO 3/14/12				enfr		M.CHENG 12/19/00				type Product Customer Drawing			
AG ELX-N-13786 Henry 01/02/13				chr		M.CHENG 12/19/00							
AH ELX-N-14061 Henry 02/18/13				appd		M.CHENG 12/19/00							
sheet index		revision sheet		AJ AJ AJ									
		1 2 3											

PRODUCT NO. ④	DIM. A	DIM. B	DIM. C	STYLE	POSITIONS LOADED	CONTACT PLATING ①	NOTES
69255-X01YLF	-	-	15.62/0.615	UNKEYED	ALL	5u" Au + high performance lubricant	-
-X02YLF	1.25 /0.050	2.69 /0.106	15.62/0.615	KEYED	ALL	5u" Au + high performance lubricant	-
-X03YLF	-	-	15.62/0.615	UNKEYED	2,3,4,5,6,7	5u" Au + high performance lubricant	-
-X04YLF	-	-	15.62/0.615	UNKEYED	ALL	5u" Au + high performance lubricant	-
-X05YLF	-	-	15.62/0.615	UNKEYED	ALL	1.27um /50u" GXT	-
-X06YLF	1.25 /0.050	2.69 /0.106	15.62/0.615	KEYED	ALL	1.27um /50u" GXT	-
-X07YLF	-	-	15.62/0.615	UNKEYED	ALL	5u" Au + high performance lubricant	NOTE 5
-X08YLF	-	-	15.62/0.615	UNKEYED	3,4,5,6	5u" Au + high performance lubricant	-
-X09YLF	-	-	15.62/0.615	UNKEYED	ALL	5u" Au + high performance lubricant	NOTE 6
-X10YLF	-	-	13.62/0.536	UNKEYED	ALL	5u" Au + high performance lubricant	NOTE 6

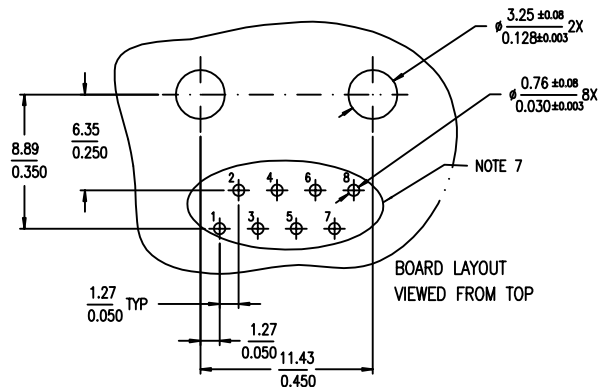

NOTES :

- ① SPECIAL PACKAGING.
- ② SOLDER TAIL LENGTH :
 X = 0 [3.18 ±0.51 /0 .125 ±0.020]
 X = 1 [8.13 ±0.51 /0 .320 ±0.020]
 X = 2 [5.30 ±0.51 /0 .208 ±0.020]
 X = 3 [3.70 ±0.51 /0 .145 ±0.020]
 X = 4 [4.50 ±0.51 /0 .177 ±0.020]
 [FOR X = 1 TO 4 , IF WIRE TRUE POSITION IS NOT APPLICABLE.]
 [PACKAGING SPEC. IS GS-14-428]
- ③ COLOR OF HOUSING :
 Y = NIL (BLACK HOUSING)
 Y = W (WHITE, RAL1013 HOUSING)
 Y = G (GRAY, HOUSING)
- ④ SPECIAL REQUIREMENT :
 SEE DETAIL C FOR P/N 69255-001B FOR FEATURE DETAILS.
- ⑤ NO PANEL STOPS ON -X09Y AND -X10Y.
- ⑥ THIS PIN NUMBERING OPPOSITE TO FCC, PART 68, SUB-PART F REQUIREMENTS
- ⑦ PART NUMBERS WITH LF IN THE END ARE LEAD FREE.
- ⑧ THIS PRODUCT MEETS EUROPEAN UNION DIRECTIVES AN OTHER COUNTRY REGULATION AS DESCRIBED IN GS-22-008.
- ⑨ THE HOUSING TEMPERATURE WITHSTAND EXPOSURE TO 260°C PEAK TEMPERATURE FOR 15 SECONDS IN A WAVE SOLDER APPLICATION WITH A 1.5 MM MINIMUM THICK CIRCUIT BOARD. SEE APPLICATION NOTES/PROCEDURES IF THEY ARE AVAILABLE.
- ⑩ PLATING OPTION:
 MAY BE EITHER GOLD OR GXT PLATED AT MANUFACTURER'S OPTION.

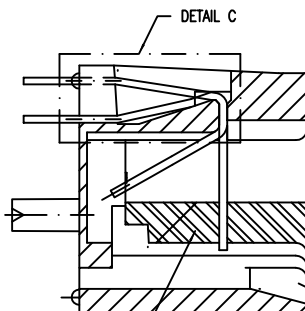
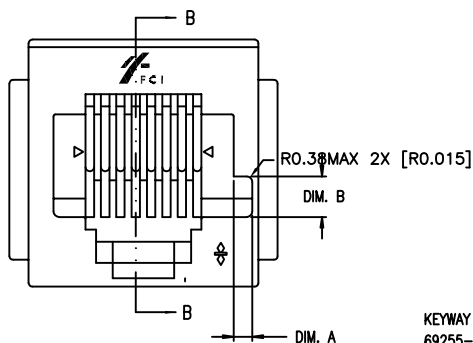

KEYWAY OPTION ON 69255-002LF & -006LF ONLY.

KEYED STYLE

SPECIAL BEND REQUIRED BY CUSTOMER FOR P/N 69255-001BLF

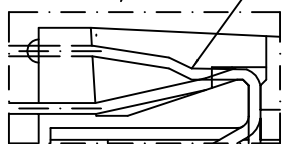

DETAIL C (OPTIONAL DESIGN)

SECTION B-B

mat'l. code		surface		tolerance		projection		product family	
		ISO1302		ISO1101 ISO406		mm		MOD JACK	
lfr	ecn no	dr	date	tolerances unless otherwise specified				title	
AJ	ELX-N-15334	Henry	07/18/13	angles	0.X±0.3	mm		8 POS VERTICAL	
-	-	-	-	chamf	0.XX±0.15	mm		PC.B. MOD JACK ASSY	
AD	N08-0239	MHT	11/10/08	0°±2'	0.XXX±0.05	scale 2.0		dwg no	
AE	N09-0092	SH MNO	01/13/10	dr	JANET	2/22/00	sheet, 2 of 3		size
AF	ELX-N-010675	SH MNO	3/14/12	enfr	M.CHENG	12/19/00	69255		A4
AG	ELX-N-13786	Henry	01/02/13	chr	M.CHENG	12/19/00	type		Product Customer Drawing
AH	ELX-N-14061	Henry	02/18/13	appd	M.CHENG	12/19/00			
sheet	revision								
index	sheet								

PRODUCT NO. ④	DIM. A	DIM. B	DIM. C	STYLE	POSITIONS LOADED	CONTACT PLATING ①	NOTES
69255-X01YHLF	-	-	15.62/0.615	UNKEYED	ALL	5u" Au + high performance lubricant	-
-X02YHLF	1.25 /0.050	2.69 /0.106	15.62/0.615	KEYED	ALL	5u" Au + high performance lubricant	-
-X03YHLF	-	-	15.62/0.615	UNKEYED	2,3,4,5,6,7	5u" Au + high performance lubricant	-
-X04YHLF	-	-	15.62/0.615	UNKEYED	ALL	5u" Au + high performance lubricant	-
-X05YHLF	-	-	15.62/0.615	UNKEYED	ALL	1.27um /50u" GXT	-
-X06YHLF	1.25 /0.050	2.69 /0.106	15.62/0.615	KEYED	ALL	1.27um /50u" GXT	-
-X07YHLF	-	-	15.62/0.615	UNKEYED	ALL	5u" Au + high performance lubricant	NOTE 1
-X08YHLF	-	-	15.62/0.615	UNKEYED	3,4,5,6	5u" Au + high performance lubricant	-
-X09YHLF	-	-	15.62/0.615	UNKEYED	ALL	5u" Au + high performance lubricant	NOTE 6
-X10YHLF	-	-	13.62/0.536	UNKEYED	ALL	5u" Au + high performance lubricant	NOTE 6

MEETS PIP PROCESS PRODUCT NO.

mat'l. code				surface ISO1302 <input checked="" type="checkbox"/>		tolerance ISO1101 ISO406		projection 		product family MOD JACK			
lfr	ecr no	dr	date	tolerances unless otherwise specified						title			
AJ	ELX-N-15334	Henry	7/18/13	angles	0.X±0.3		mm		8 POS VERTICAL				
-	-	-	-	0°±2'	0.XX±0.15		scale 2.0		PC.B. MOD JACK ASSY				
AD	N08-0239	MHT	11/10/08	0°±2'	0.XXX±0.05		FCI		dwg no sheet, 3 of 3 size				
AE	N09-0092	SH MM0	01/13/10	dr	JANET	2/22/00	FCI		69255 A4				
AF	ELX-N-010675	SH MM0	3/14/12	enfr	M.CHENG	12/19/00	FCI		type Product Customer Drawing				
AG	ELX-N-13786	Henry	01/02/13	chr	M.CHENG	12/19/00	FCI						
AH	ELX-N-14061	Henry	02/18/13	appd	M.CHENG	12/19/00	FCI						
sheet index	revision sheet												