

S4-R500D40

Coming Soon! In-Testing, Expected Release January 2020.

The S4-R500D40 is a shock recorder with a high performance piezoresistive accelerometer, a secondary capacitive accelerometer and other environmental sensors. This model is most popular for shock testing. Its aluminum enclosure improves reliability in harsh environments and widens its frequency response.

Product Features

- **Convenient, Configurable, and Reliable** [Learn More](#)
- **Standalone Measurement System**
Embedded sensors, storage & power
- **Selectable High-Performance Accelerometers**
Variable capacitance, piezoelectric & piezoresistive
Selectable measurement range from 16g to 2,000g
Selectable sampling rate up to 20,000 samples per second
- **Up to 4 Billion Data Points of Memory**
- **Embedded Sensor Suite**
Gyroscope, magnetometer, pressure, temperature, humidity & light
- **Triggering from Sensors and/or Time-Based**
- **Rechargeable Battery Life of Over 4 Hours Continuous**
Can operate with external power
- **Simple USB Interface for Download & Charging**
- **NIST Traceable Calibration**
- **Trusted by Over 1,500 Different Commercial Customers**

Accelerometer Specifications

Accelerometer Type	Range	Sampling Rate	Bandwidth	Noise	Resolution
Piezoresistive	± 500g	20,000 Hz	0 to 2,000 Hz	< 0.40 gRMS	0.015 g
Digital Capacitive	± 40g	4,000 Hz	0 to 300 Hz	< 0.01 gRMS	0.00008 g

Frequency Response Plot

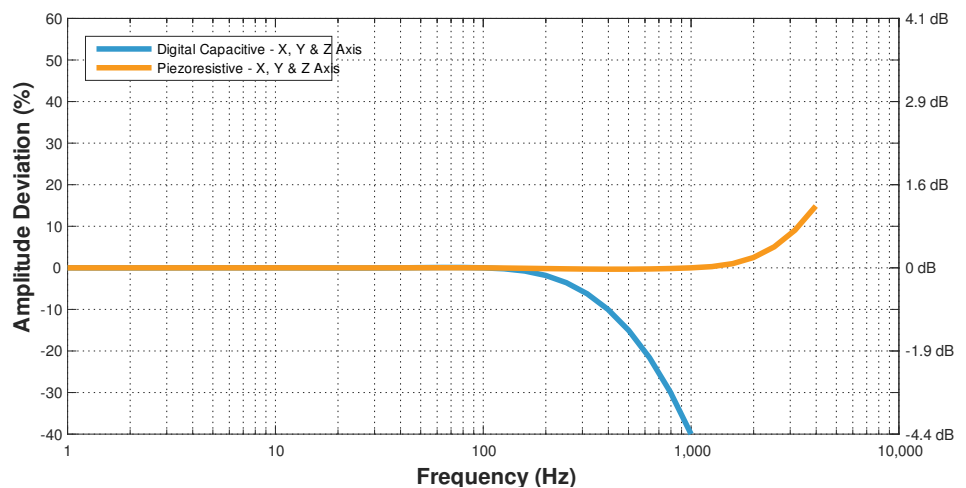

Battery & Storage Performance

Battery performance is heavily dependent upon the device configuration (sensor sample rates and triggers), battery age (including charging cycles), and temperature. The following table provides the battery life and storage capacity of this device assuming it has a relatively new battery and it is at room temperature. When showing performance it

assumes all sensors are on at the default sample rate with the main accelerometer sample rate driving performance. With triggers, it assumes the device is in trigger mode 99% of the time. Here are some additional resources: [Setting Sensor Configuration](#), [Battery Specifications](#), [Battery Life Estimator Tool](#).

Sample Rate	Storage Capacity	Continuous Recording	Main Accel. Trigger	2nd Accel. Trigger	Periodic/Time Trigger
100 Hz	22 days	11 hours	17 hours	64 hours	45 days
1,000 Hz	9 days	11 hours	17 hours	64 hours	43 days
5,000 Hz	63 hours	9 hours	16 hours	63 hours	36 days
20,000 Hz	17 hours	5 hours	16 hours	60 hours	22 days

Dimensions

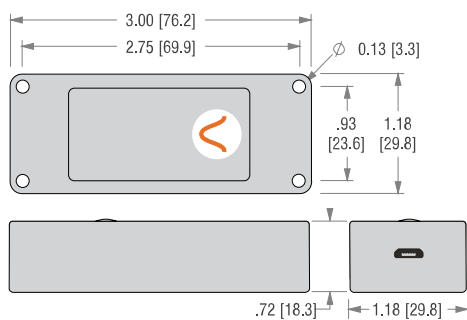

Mechanical Specifications

Mass	65 grams
Case Material	Aluminum 7075
Mounting - Screw	4-40 Bolts (100 in-oz)
Mounting - Tape (Double Sided)	3M 950 Tape
Length	76.2 mm (3.00")
Width	29.8 mm (1.18")
Thickness	18.3 mm (0.72")
Ingress Protection	IP 50 (Dust Protected)

Free Software Features

- **Free Standalone Software Packages** [Lab](#) - Configuration, Quick Snapshot, Batch File Conversion [Analyzer](#) - Analysis of enDAQ Sensor Data in MATLAB
- **Configure Sensors for Measurement**
- **Export/Convert Data to CSV or MATLAB**
- **Analysis** FFT PSD Spectrogram Digital Filtering

