

LOC		DIST		REVISIONS			
P	LTR	DESCRIPTION	DATE	DWN	APVD		
Z		REV PER ECO 15-016064	11-9-15	CT	CD		

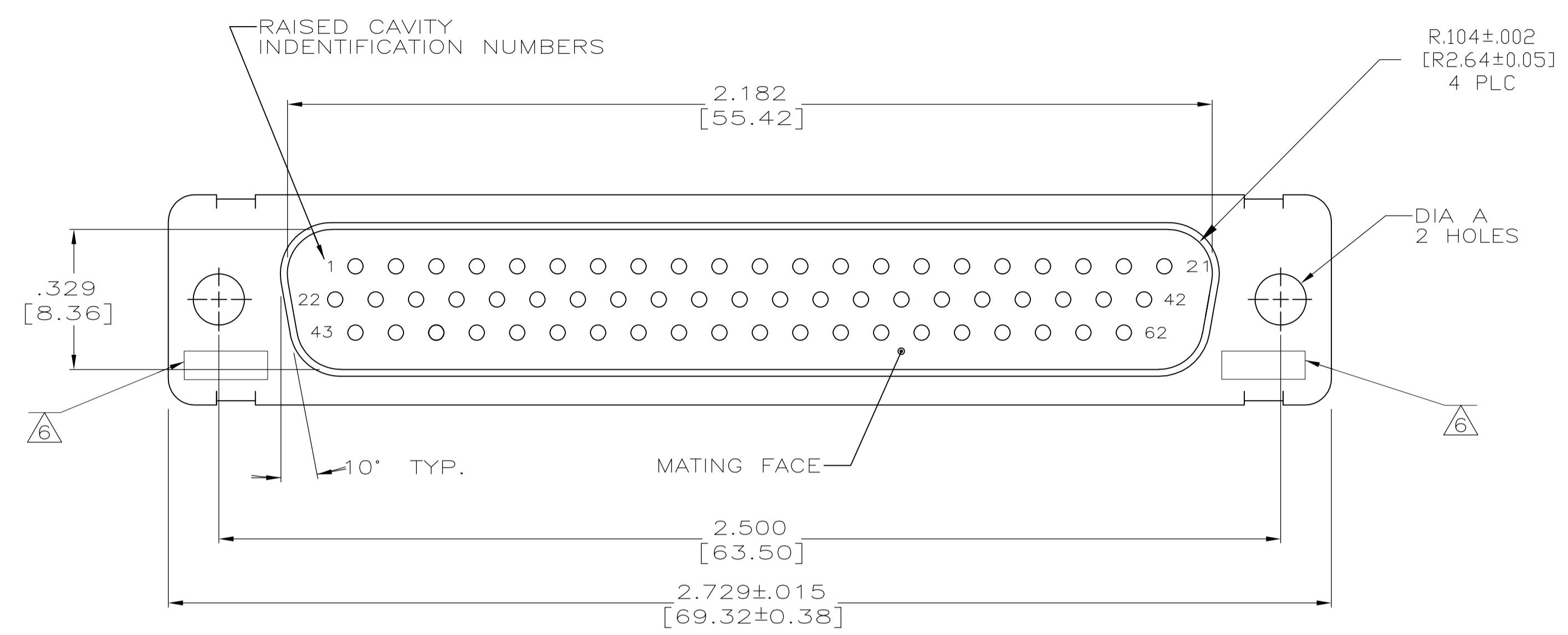

- THIS PLUG WILL MATE WITH ANY RECEPTACLE CONNECTOR WITH THE SAME INSERT ARRANGEMENT AS DEFINED BY MS18276-2.
 - MAXIMUM WIRE INSULATION USED WITH THIS PLUG IS .054 [1.37] DIA.
 - Be-Cu RETENTION CLIPS ARE INCLUDED IN INSERTS.
- △4 INSPECTION REQUIREMENTS PER R4383.
 - △5 CONNECTOR SUPPLIED WITH 69 CONTACTS, AMP PART NUMBER 204370-8. INSPECTION REQUIREMENTS PER R4383 WITHOUT TESTS FOR HIGH ALTITUDE DIELECTRIC WITHSTANDING VOLTAGE AS CALLED FOR IN TABLE II SCREENING AND TESTING.
 - △6 UL/CSA DESIGNATION STAMPED IN THIS AREA, OPTIONAL.
 - △7 CONNECTOR LOADED WITH POSTED CONTACTS. INSPECTION REQUIREMENTS PER GENERAL ELECTRIC DOCUMENT 20025720.
 - △8 RESTRICTED TO CAE ELECTRONICS ONLY.
 - △9 THESE CONNECTORS ARE QUALIFIED TO GODDARD SPACE FLIGHT CENTER SPECIFICATION S-311-P-4.
 - △10 CONNECTOR LOADED WITH POSTED CONTACTS.
 - △11 CONNECTOR LOADED WITH POSTED CONTACTS. INSPECTION REQUIREMENTS PER LM DOCUMENT 20131204.

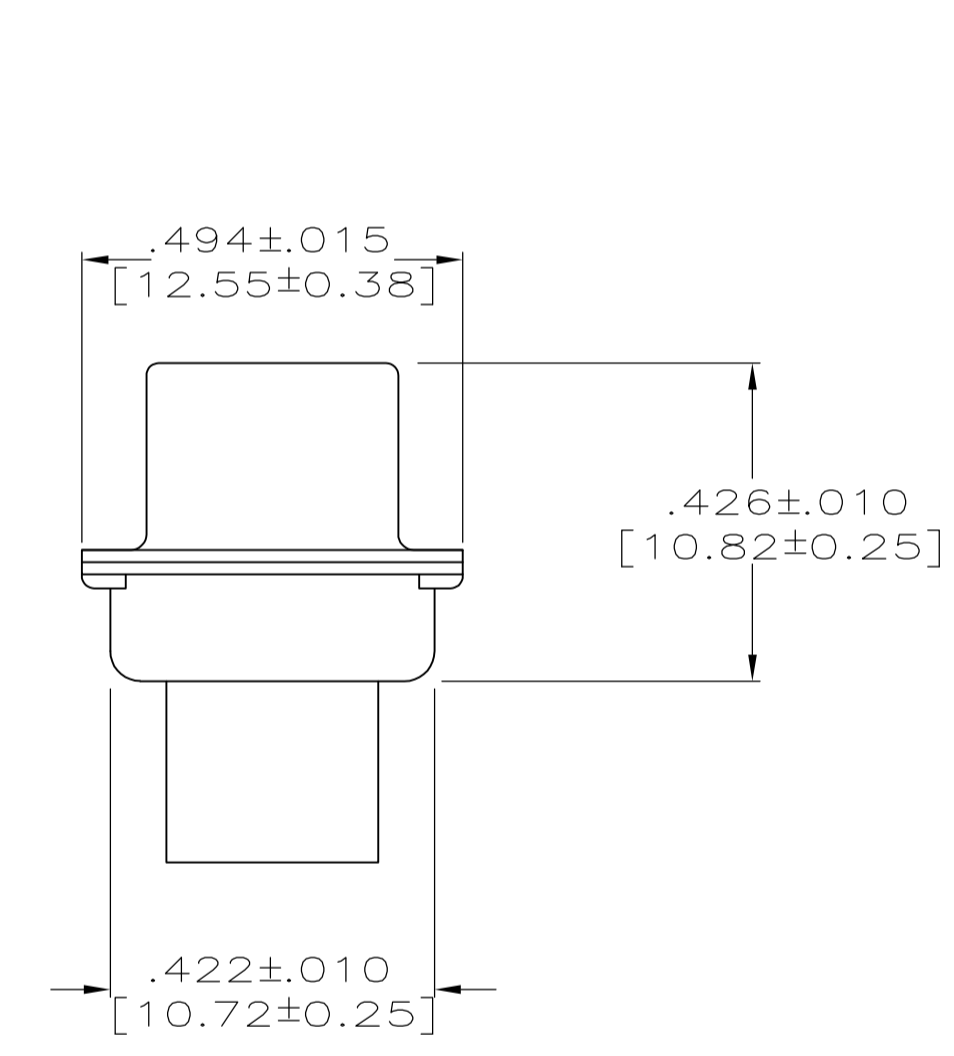
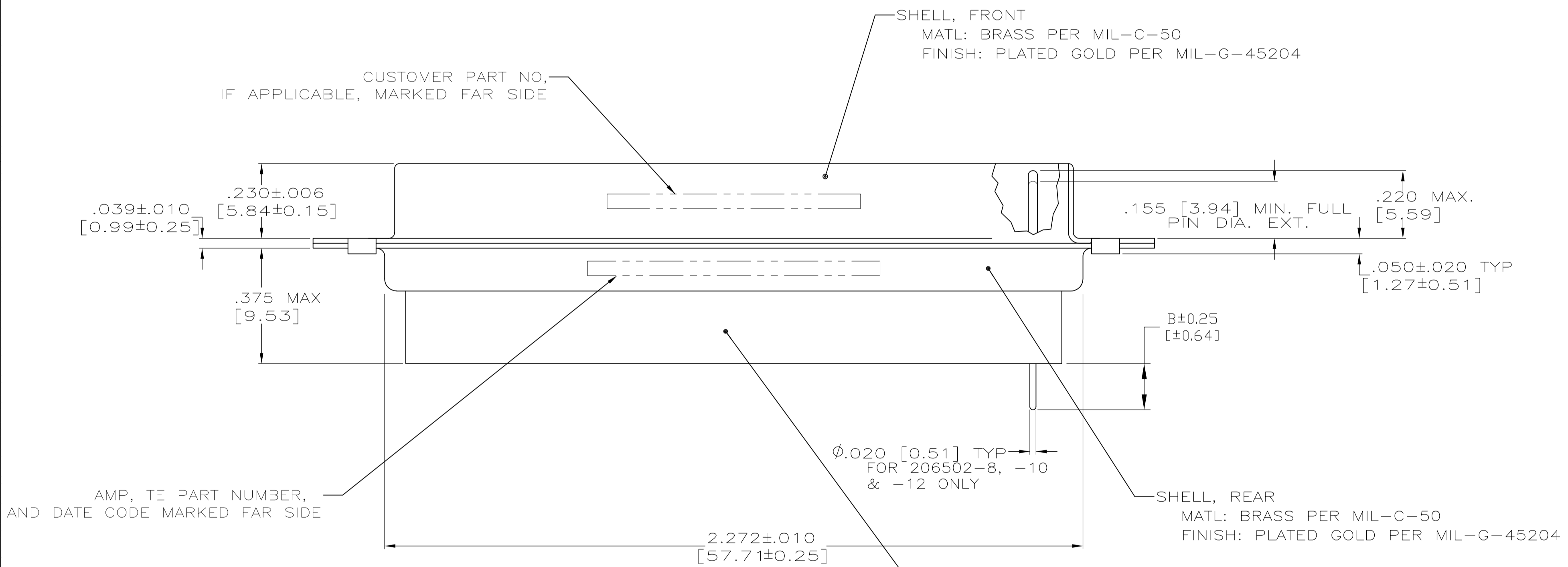

TE PART NUMBER 204370-8
GSFC PART NUMBER G-08-P1
(SUPPLIED WITH 206502-6 ONLY)

INSERT ASSEMBLY
MATL: DIALLYL PHTHALATE, TYPE SDG-F
PER MIL-M-14,
COLOR: BLUE
OR POLYPHENYLENE SULFIDE (PPS) COLOR: BLACK
PER MIL-M-24519, TYPE GST-40F.

△11	.150 [3.81]	.120 [3.05]	20131204P2062P	1-206502-2	1-206502-2
	--	.120 [3.05]	570566-10	1-206502-1	1-206502-1
△10	.175 [4.45]	.120 [3.05]	--	1-206502-0	1-206502-0
△9/△8	--	.120 [3.05]	311P407-4P-B-12	206502-4	206502-9
△7	.150 [3.81]	.120 [3.05]	20025720P2062P	206502-8	206502-8
	--	.154 [3.91]	SC81D139-054	206502-7	206502-7
△5	--	.120 [3.05]	R4383P62P	206502-6	206502-6
△4	--	.120 [3.05]	R4383P62P-2	206502-5	206502-5
△3	--	.120 [3.05]	311P407-4P-B-12	206502-4	206502-4
	--	.154 [3.91]	----	206502-3	206502-3
	--	.120 [3.05]	R9259P62P	206502-2	206502-2
△2	--	.154 [3.91]	311P407-4P-B-15	206502-1	206502-1
REMARKS	DIA B	DIA A	CUSTOMER P/N ON CONNECTOR	TE P/N ON CONNECTOR	TE P/N

THIS DRAWING IS A CONTROLLED DOCUMENT.

DIMENSIONS: INCHES	TOLERANCES UNLESS OTHERWISE SPECIFIED:	DWN: M. CLOUSER 12-16-88	CHK: T. CANTLIN 12-16-88	APVD: F. BALLOW 12-16-88	NAME: AMPLIMITE NONMAGNETIC PLUG ASSEMBLY, SERIES 90, SHELL SIZE 4, 62 POSITION
0 PLC ± .005	1 PLC ± .005	2 PLC ± .005	3 PLC ± .005 [0.13]	4 PLC ± .005	ANGLES ± 0°30'
MATERIAL: SEE CALLOUTS	FINISH: SEE CALLOUTS	WEIGHT: --	SIZE: A1	CAGE CODE: 00779	DRAWING NO: 206502
CUSTOMER DRAWING			SCALE: 4:1	SHEET: 1 OF 1	REV: Z

STE TE Connectivity