

## BDE40 : 11 to 36 V DC - 10 A nominal BDE40 Part number 84855101



### Control of all 3-phase brushless Hall effect motors

- 4 quadrants, for closed-loop speed control, torque, holding and power braking control
- Ready for use, supplied with guide, braking resistor, protection diodes and connectors
- For use alone or with a PLC (0-10 V and PWM compatible inputs)

### Part numbers

Type	Type
84855101 BDE40	848551

### Specifications

Supply voltage (V)	11 →36 (= V DC)
Nominal current (A)	10
Max. current (A)	14 (internal limiting)
Absorbed current (A)	0,1 (consumption without motor)
Temperature rise (°C)	50
Ambient operating temperature (°C)	-20 →40
Storage temperature (°C)	-40 →90
Weight (g)	305

### Safety standards

#### On/Off input and Direction of rotation input

Input impedance (kΩ)	59
Level 0 input voltage (VDC)	< 2
Level 1 input voltage (V)	4 →V DC

#### Speed input and Torque limit / holding / braking input (0-10 V and PWM)

Input impedance (kΩ)	10
Control voltage	0 →10 V
Level 0 input voltage (V)	0
Level 1 input voltage (V)	11,5 →V DC
Frequency (Hz)	100 →1000

### Hall effect inputs

#### Output

Type PNP open collector	•
Max. current (A)	0,02

#### Encoder output

Rest state (V)	+ V DC
Number of 250 μs pulses per motor revolution	3 x number of rotor poles

#### Torque limit reached output

Rest state (V)	0
Active torque limitation (V)	+ V DC

### Principles



#### Speed setpoint

Adjustable between 10 % and 100 % of 6000 rpm by PWM signal or analogue (0-10 V) signal.

#### Torque limit

Adjustable between 10 % and 140 % of the nominal card current by PWM signal or analogue 0-10 V signal. If the control is at 0 % or 0 V or non-connected, the current limit is 140 %.

If the current in the motor reaches the specified limit, the "active limiting" output switches to the "+ supply voltage" value and the current in the motor is automatically limited.

Since the torque value is directly related to the current in the motor, the torque limit can be set in this way.

Make sure that this setpoint is set correctly to avoid exceeding the capacities of the motor used.

#### Holding torque

Activates if on/off= 1 and speed setpoint= 0.

Its value depends on the "torque limit" setpoint.

#### Encoder and actual direction of rotation outputs

These two related outputs are used for positioning purposes, using the "high-speed counting" function of a Millenium or other PLC with high-speed inputs (>40 K Hz in order to correctly manage the "actual direction of rotation" information and to be able to "upcount and downcount" without losing pulses on changing direction).

#### Overheating protection

If the temperature is too high, the protection activates and shuts off the motor. After it has cooled down, an action at the "on/off" input (switching "off" and then "on" again) is required in order to restart the motor.

Overheating is detected at the card and at the motor (if the motor is fitted with an NTC, such as BDE40-compatible motors 801405 and 801805).

**Undervoltage protection**

If the supply voltage becomes insufficient, the protection activates and shuts off the motor. The motor restarts automatically as soon as the supply voltage returns to the operating range.

**Principles****Braking**

The braking torque value is adjustable and is controlled by means of the "torque limit" setpoint.

The electronic card has two internal devices for dissipating braking energy. The first system is designed for low dissipation values, the second for higher values.

The first system limits overvoltages to 42 V. For inertias and low speeds, this device is adequate.

Example of usage restriction :

- Braking every 8 seconds of  $14.5 \cdot 10^{-4} \text{ kg.m}^2$  from 3000 rpm to 0 rpm.

- Braking every 8 seconds of  $25.4 \cdot 10^{-4} \text{ kg.m}^2$  from 2000 rpm to 0 rpm.

- Caution : If the specified limits are exceeded, this device will overheat and destroy the card.

In case of doubt, or if the braking phase is long or very frequent, the second internal braking circuit must be used ; this requires an external energy dissipation resistor. In this case the trip threshold for this braking can be set to values below 42 V by means of a jumper on the side of the card.

**Overvoltage limiting jumper**

Located on the side of the card ; various positions allow overvoltages due to heavy braking to be reduced.

Always set the jumper to a value greater than or equal to the "supply voltage + 2 V" to avoid disrupting the power supply.

**Number of poles jumper**

In order to limit the rotational speed to 6000 rpm, this jumper must be set to the number of "pairs of rotor poles" on the motor used.

Otherwise the speed will be adjusted within a different range. For example, a 4-pole motor (2 pairs) and a jumper set to 4 pairs will give a speed range of up to 12000 rpm. On the other hand, with an 8-pole motor (4 pairs) and a jumper set to 2 pairs, the speed range will be limited to 3000 rpm.

**Braking resistor**

The control card is supplied with a braking resistor to enable you to carry out your tests. However, you must check that its characteristics correspond to your requirements. Depending on your application, it is possible that it may overheat, in which case it will have to be replaced with a more suitable resistor.

The lower the resistor value, the higher the braking current. Typical values are in the region of a few ohms. The resistor must also be matched to the dissipation power (average and peak), see the guide supplied with the card.

The card is supplied with a  $3.3 \Omega - 25 \text{ W}$  resistor.

**"Non-return" diodes**

In some cases, overvoltages due to braking must be prevented from returning to the power supply or other equipment (see "braking" in the basic concepts). If necessary, use the diodes supplied with the card. For connections please refer to the guide supplied with the card.

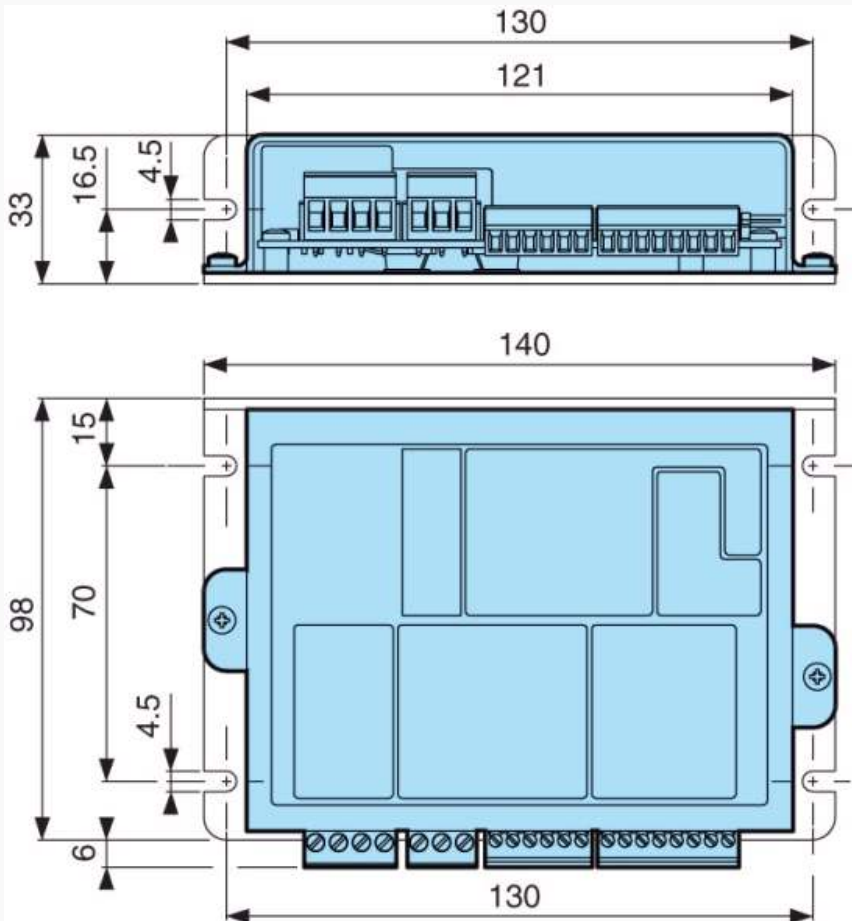
**Dimensions (mm)****Curves****Motor 80190502**

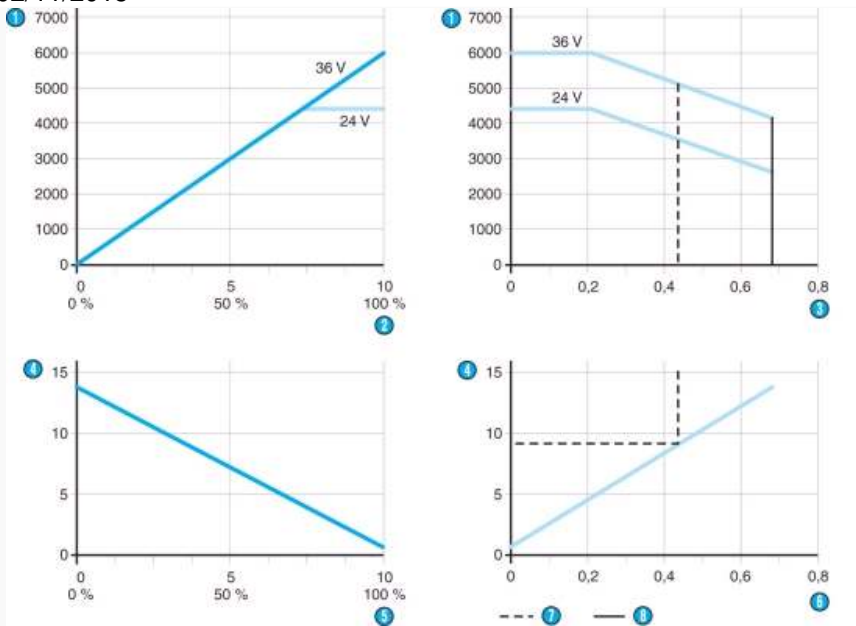

N°	Legend
1	Speed (RPM)
2	Speed setpoint
3	Torque (Nm)
4	Current (A)
5	Torque limit setpoint
6	Torque (N.m)
7	Nominal torque
8	Peak torque

**Curves**

**Motor 80180506**

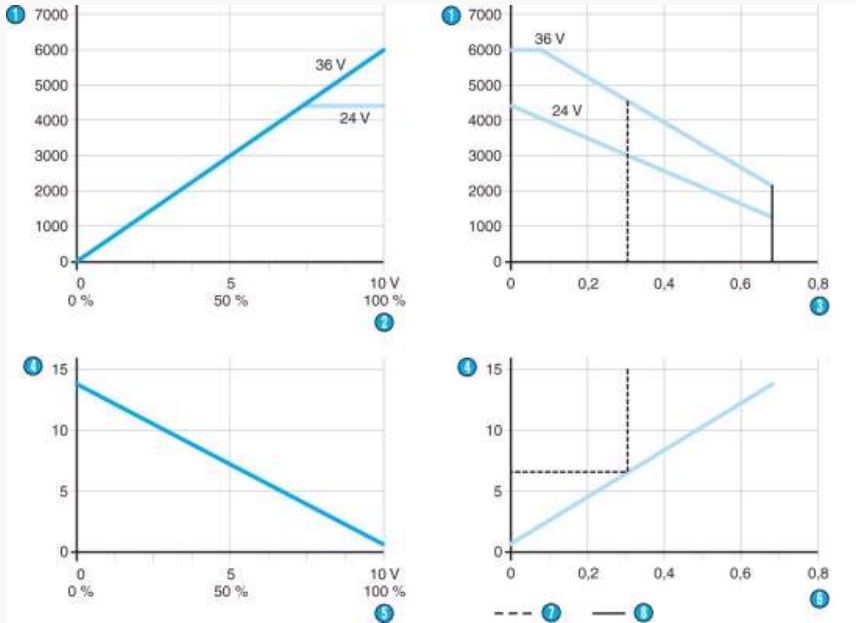

N°	Legend
1	Speed (RPM)
2	Speed setpoint
3	Torque (Nm)

①	Current (A)
②	Torque limit setpoint
③	Torque (N.m)
④	Nominal torque
⑤	Peak torque

**Curves**

**Motor 80140510**

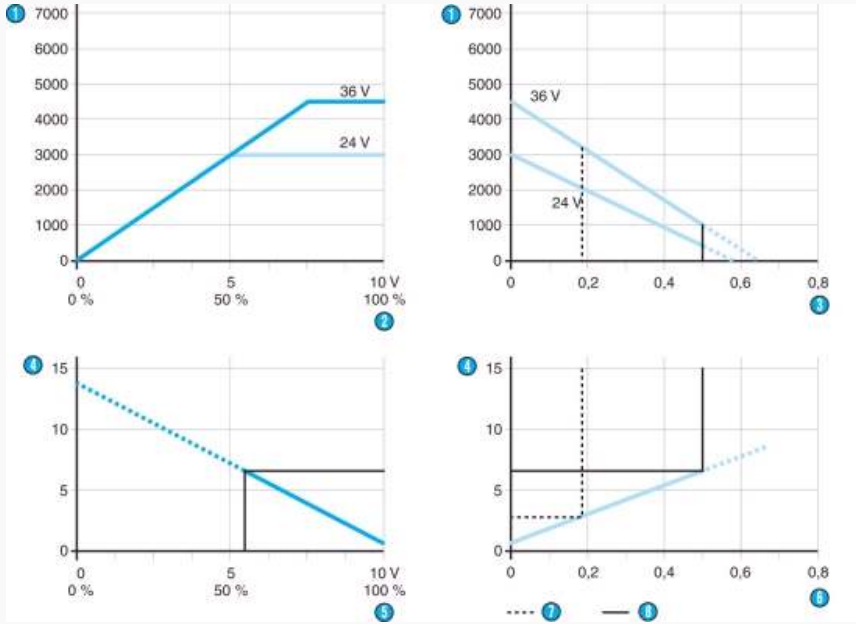

N°	Legend
①	Speed (RPM)
②	Speed setpoint
③	Torque (Nm)
④	Current (A)
⑤	Torque limit setpoint
⑥	Torque (N.m)
⑦	Nominal torque
⑧	Peak torque

**Connections**

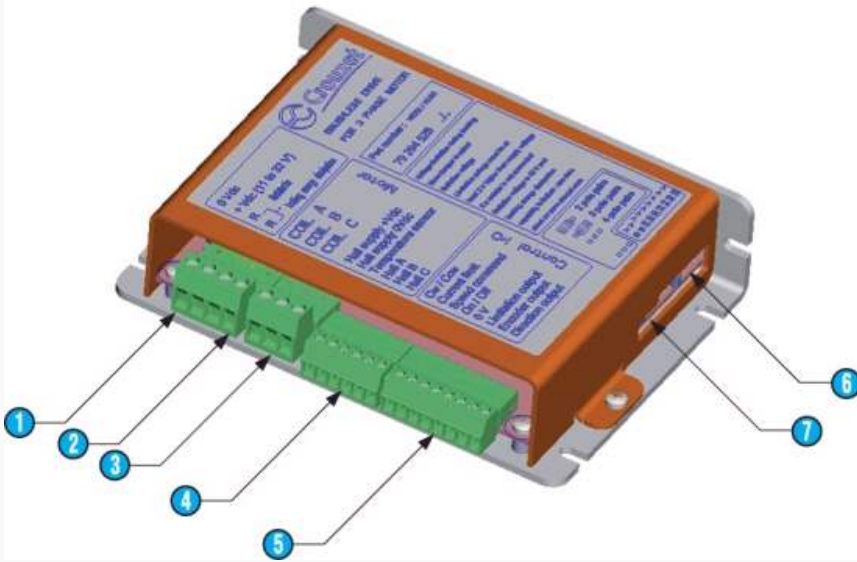

P1 : Supply connector 1 : 0 V 2 : + V DC 3 - 4 : Braking energy dissipation resistor P2 : Motor power 1 : Phase 1 2 : Phase 2 3 : Phase 3 P3 : Hall sensors 1 : Hall supply output +10 V DC 2 : 0 V DC Hall supply 3 : Temperature sensor 4 : Hall sensor 1 5 : Hall sensor 2 6 : Hall sensor 3 P4 : Control I/O 1 : Direction of rotation 2 : Current limit 3 : Speed control 4 : On/off 5 : 0 V 6 : Current limiting output 7 : Encoder output 8 : Actual direction of rotation output

N°	Legend
1	Supply voltage
2	Braking resistor
3	Motor windings
4	Motor Hall effect
5	Inputs and outputs
6	Braking overvoltage limiting jumper
7	Number of pairs of rotor poles selection jumper

**Connections**

Examples of connection diagram with a Millennium 3 logic controller or a PLC

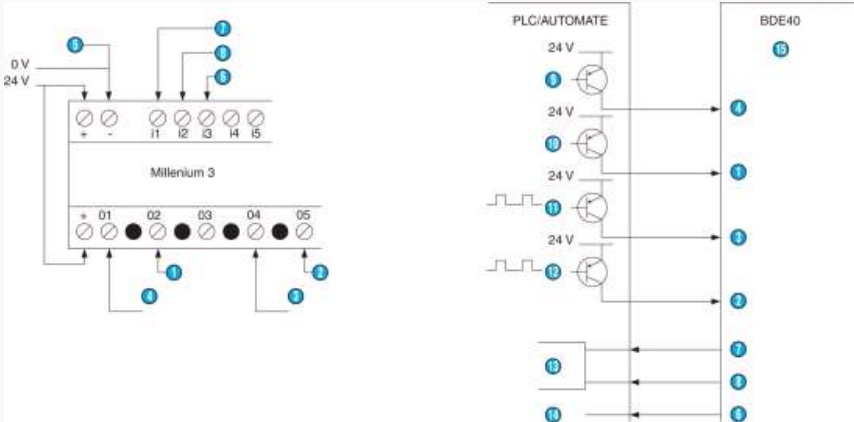

NB : The "tachometer" and "actual direction of rotation" card outputs must be connected to inputs i1 and i2 respectively in order to be able to use the Motomate high-speed counter function.

N°	Legend
1	Direction input
2	Torque limit input
3	Speed setpoint input
4	On/off input
5	Ground
6	Active limiting output
7	12 points/rev encoder output

8	Direction of rotation output
9	Digital PNP output
10	Digital PNP output
11	PWM 100 Hz to 1 K Hz
12	PWM 100 Hz to 1 K Hz
13	24 V counter input (40 K Hz minimum)
14	24 V digital input
15	Control connector

#### Product adaptations



- Optimisation of settings according to individual applications (speed and torque limit ranges, speed controller parameters, current limits)
- Versions available without accessories (connectors, resistor, diodes, casing)
- Some programming elements for your machine's automation system can be integrated into the card micro-controller