

Mechanical Guidance Modules

HIGH FLEXIBILITY AND PERFORMANCE CONNECTOR

Guidance modules assure proper connector alignment prior to connector engagement and are suitable for backplane, coplanar or orthogonal midplane applications in Hard Metric environments. Modules fitting 20mm slot pitch complement AirMax® 4-Pair or 5-Pair modules or ZipLine 6-Pair signal modules. Modules fitting 17mm slot pitch complement AirMax 3-Pair signal modules or can be used with taller signal modules to provide more clearance for airflow.

- 20mm slot ideal for AirMax 4-Pair or 5-Pair modules or ZipLine 6-Pair signal modules
- 17mm slot ideal for AirMax 3-Pair signal modules
- Can be used with taller signal modules to provide more clearance for airflow.



TARGET MARKETS



FEATURES

- Rugged metal components fastened to boards with screws
- 7.2mm guide blades carry maximum weight in small space
- Free standing guidance components
- 10.8mm modules have guidance, coding, and ESD clips
- Hardware applications

BENEFITS

- Mechanically robust guidance
- Optimizes board edge real estate
- Maximizes design flexibility
- Enables board polarization and grounding
- Flexible design supports right angle and coplanar applications

TECHNICAL INFORMATION

MATERIAL

- Base metal: Zinc alloy
- Finish:
 - Body: Zinc yellow chromate
 - ESD contact: Nickel

TARGET MARKETS/APPLICATIONS



Switches
Access
Wireless Base Station
Switching
Base Station
Telecom
Datacom
Datacom/Networking Equipment
Cluster/Navigation
AC/DC pluggable power supplies



Rack Mount Server
Blade Server
Storage Server
Datacenter
Storage System
Router and Server
Datacenter switching applications
Control Boards



Lighting
Control Drives
Test Equipment
Power Supplies
Access Control
Industrial Controls & Instruments
Automation



Medical Instruments



Lighting
Car Navigation Systems

Renewable Energy
Aerospace
Aviation

MECHANICAL PERFORMANCE

- Misalignment correction:
 - Pin-style modules: +/- 3.5mm max. in direction perpendicular or parallel to daughter card
 - Blade-style modules: +/- 2.9mm max. in direction perpendicular or parallel to card
- Clearance after full guidance:
 - Pin-style modules: 0.35mm nominal (0.175mm surrounding the pin) between pin and receptacle
 - Blade-style modules: 0.25mm nominal (0.125mm per side in the direction perpendicular to the daughter card and 0.30mm nominal (0.15mm per side) in the direction parallel to the daughtercard

APPROVALS AND CERTIFICATIONS

- Lead-free and RoHS compliant

PACKAGING



- Trays (guide pins)
- Tubes (guide modules)

SPECIFICATIONS

- Application specification: GS-20-045

ROBUST MECHANICAL DIE CAST GUIDE MODULES

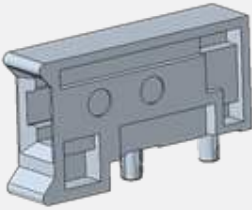
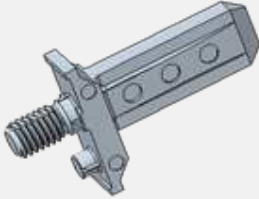
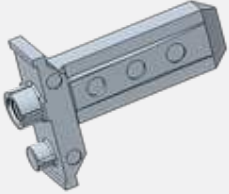
APPLICATIONS: BACKPLANE, COPLANAR, AND ORTHOGONAL ARCHITECTURES

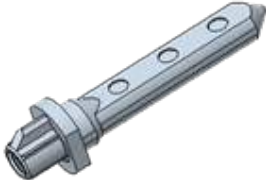
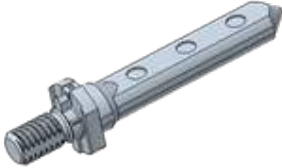
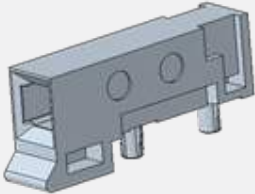
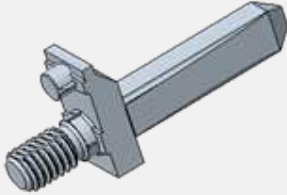
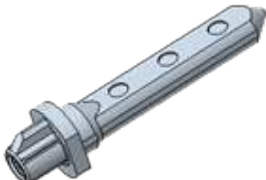
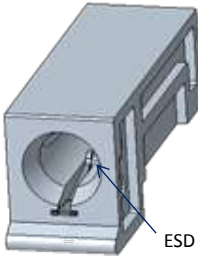
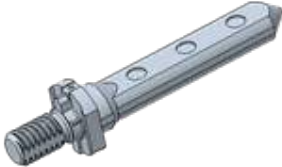
Application	Receptacle	Header
AirMax/ExaMAX 4-, 5-, 6- & 8-Pair	 <p>Receptacle Type=7.2mm 10037909</p>	 <p>Type=7.2mm Length=25.3mm External Thread 10037908</p>
		 <p>Type=7.2mm Length=25.3mm Internal Thread 10066832</p>
	 <p>Receptacle Type=10.8mm ESD(optional) 10037912</p>	 <p>Type=10.8mm Internal Thread 10037911</p>
		 <p>Type=10.8mm External Thread 10037910</p>
AirMax/ExaMAX 2- & 3-Pair	 <p>Receptacle Type=7.2mm 10045367</p>	 <p>Type=7.2mm Length=25.3mm 10045368</p>
		 <p>Type=10.8mm Internal Thread 10037911</p>
	 <p>Receptacle Type=10.8mm ESD (optional) 10045597</p>	 <p>Type=10.8mm External Thread 10037910</p>

ROBUST MECHANICAL DIE CAST GUIDE MODULES

ROBUST MECHANICAL GUIDANCE MODULES FOR COPLANAR

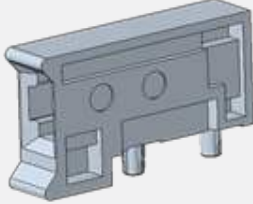
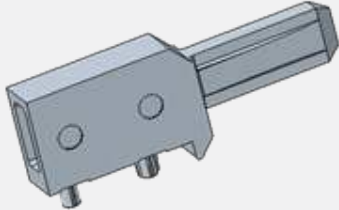
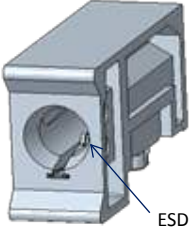
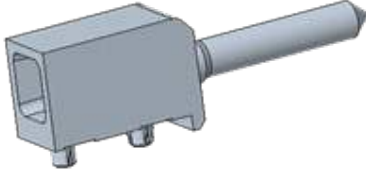
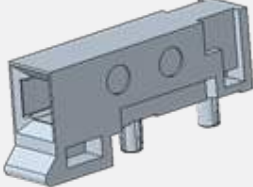
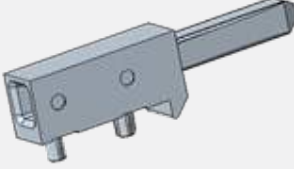
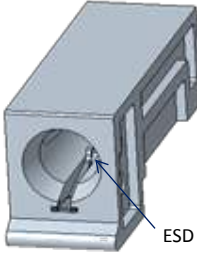
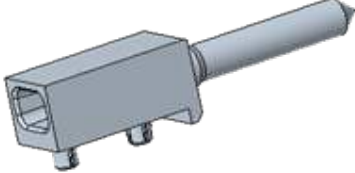
Application	Receptacle	Header
AirMax 4-& 5-Pair	 <p>Receptacle Type=7.2mm 10037909</p>	 <p>Coplanar Type=7.2mm 10044314</p>
	 <p>Receptacle Type=10.8mm ESD(optional) 10037912</p> <p>ESD</p>	 <p>Coplanar Type=10.8mm 10044366</p>
AirMax 2- & 3-Pair	 <p>Receptacle Type=7.2mm 10045367</p>	 <p>Coplanar Type=7.2mm 10045588</p>
	 <p>Receptacle Type=10.8mm ESD (optional) 10045597</p> <p>ESD</p>	 <p>Coplanar Type=10.8mm 10045509</p>

ROBUST MECHANICAL GUIDANCE MODULES FOR INVERSE COPLANAR

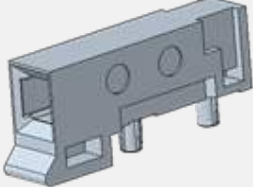
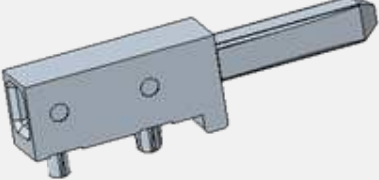
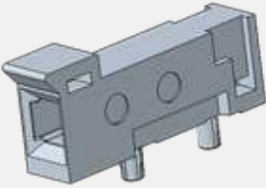
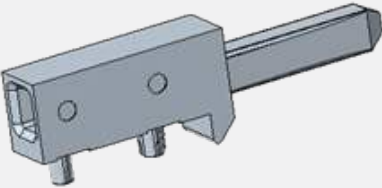
Application	Receptacle	Header
AirMax 4-Pair	 <p>Receptacle Type=7.2mm 10045367</p>	 <p>Inverse Coplanar Type=7.2mm 10101902</p>
ExaMAX 3-Pair	 <p>Receptacle Type=7.2mm 10150954</p>	 <p>Inverse Coplanar Type=7.2mm 10150953</p>

▶ Mechanical Guidance Modules

BLADE-STYLE BACKPLANE/MIDPLANE GUIDE MODULES – WITH NO KEYING OR ESD OPTIONS

Application	Minimum Card Spacing (mm)	Guide Module Width (mm)	Guide Pin Length (mm)	Guide Pin Thread Style	Product Variation	
					Backplane/Midplane	Daughtercard
					Guide Pin	Right Angle Guide Module
Backplane Guide Blade	20	7.2	18.3	External threads	10037915-101LF	10037909-101LF
	20	7.2	25.3	External threads	10037908-101LF	10037909-101LF
	20	7.2	25.3	Internal threads	10066832-101LF	10037909-101LF
	17	7.2	25.3	External threads	10045368-101LF	10045367-101LF
Coplanar Blade Receptacle	Minimum Card Slot Spacing (mm)	Guide Module Width (mm)	Guide Pin Length (mm)	Guide Pin Thread Style	Right Angle Pin	Right Angle Receptacle
	20	7.2	25.3		10044314-101LF	10037909-101LF
	17	7.2	25.3		10045588-101LF	10045367-101LF



PIN-STYLE BACKPLANE/MIDPLANE GUIDE MODULES – WITH KEYING AND ESD OPTIONS

Application	Minimum Card Spacing (mm)	Guide Module Width (mm)	Guide Pin Length (mm)	Guide Pin Thread Style	Product Variation	
					Backplane/Midplane	Daughtercard
					Guide Pin	Right Angle Guide Module
Backplane Guide Blade	20	10.8	32.0	External threads	10037910-1xxLF	10037912-1xyLF
	20	10.8	32.0	Internal threads	10037911-1xxLF	10037912-1xyLF
	17	10.8	32.0	External threads	10037910-1xxLF	10045597-1xyLF
	17	10.8	32.0	Internal threads	10037911-1xxLF	10045597-1xyLF
Coplanar Blade Receptacle	Minimum Card Slot Spacing (mm)	Guide Module Width (mm)	Guide Pin Length (mm)	Guide Pin Thread Style	Right Angle Pin	Right Angle Receptacle
	20	10.8	29.9		10044366-10yLF	10037912-1xyLF
	17	10.8	29.9		10045509-10yLF	10045597-1xyLF



y	Key Angle
1	0°
2	45°
3	90°
4	135°
5	180°
6	225°
7	270°
8	315°
9	no key

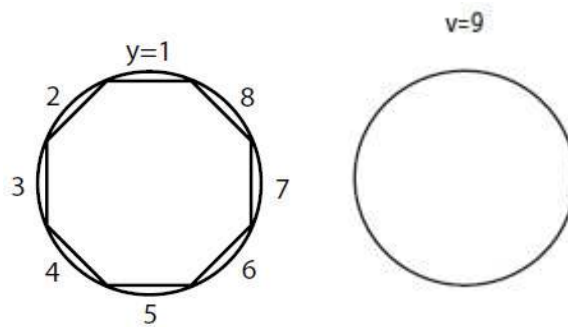

* For backplane guide pin modules, “xx” is dictated by the backplane thickness. Replace with code from product drawing. Reference the product drawing for additional information.

* For right-angle guide modules, “x” = 0 with ESD clip; “x” = 1 without ESD clip. “y” designates the keying angle option.

Reference the product drawing for additional information.

HSBPAIRMAXMGM052919A4