

AS1313

Ultra Low Quiescent Current, DC-DC Step Down Converter

General Description

The AS1313 is an ultra-low quiescent current hysteretic step-down DC-DC converter optimized for light loads and with efficiencies of up to 95%.

AS1313 operates from a 2.4V to 5.5V supply and supports output voltages between 1.2V and 3.6V. Besides the available AS1313 standard variants, any variant with output voltages in 50mV steps are available.

In order to save power the AS1313 features a shutdown mode, where it draws less than 100nA. During shutdown mode the battery is disconnected from the output.

In light load operation, the device enters an idle mode when most of the internal operating blocks are turned off in order to save power. This mode is active approximately 100 μ s after a current pulse provided that the output is in regulation. The capacitor connected to the REF pin is an essential part of this feature.

The AS1313 is available in an 8-pin MLPD (2mm x 2mm) and a 6-pin WL-CSP (0.4mm pitch).

Ordering Information and Content Guide appear at end of datasheet.

Key Benefits & Features

The benefits and features of AS1313, Ultra Low Quiescent Current, DC-DC Step Down Converter are listed below:

Figure 1:
Added Value of Using AS1313

Benefits	Features
Ideal for single Li-Ion battery powered applications	<ul style="list-style-type: none"> Wide input voltage range (2.4V to 5.5V)
Extended battery life	<ul style="list-style-type: none"> High efficiency up to 95%
Less power consumption	<ul style="list-style-type: none"> Low quiescent current of typ. 1μA Low shutdown current of less than 100nA
Supports a variety of end applications	<ul style="list-style-type: none"> Fixed output voltage range (1.2V to 3.6V) Output current of 150mA
Over-temperature protection and shutdown	<ul style="list-style-type: none"> Integrated temperature monitoring
Cost effective, small package	<ul style="list-style-type: none"> 6-pin WL-CSP with 0.4mm pitch 8-pin MLPD (2mm x 2mm)

Applications

The AS1313 is an ideal solution for Li-Ion and coin cell powered devices as:

- Blood glucose meters
- Remote controls
- Hearing aids
- Wireless mouse or any light-load application

Block Diagram

The functional blocks of this device for reference are shown below:

Figure 2:
AS1313 Block Diagram

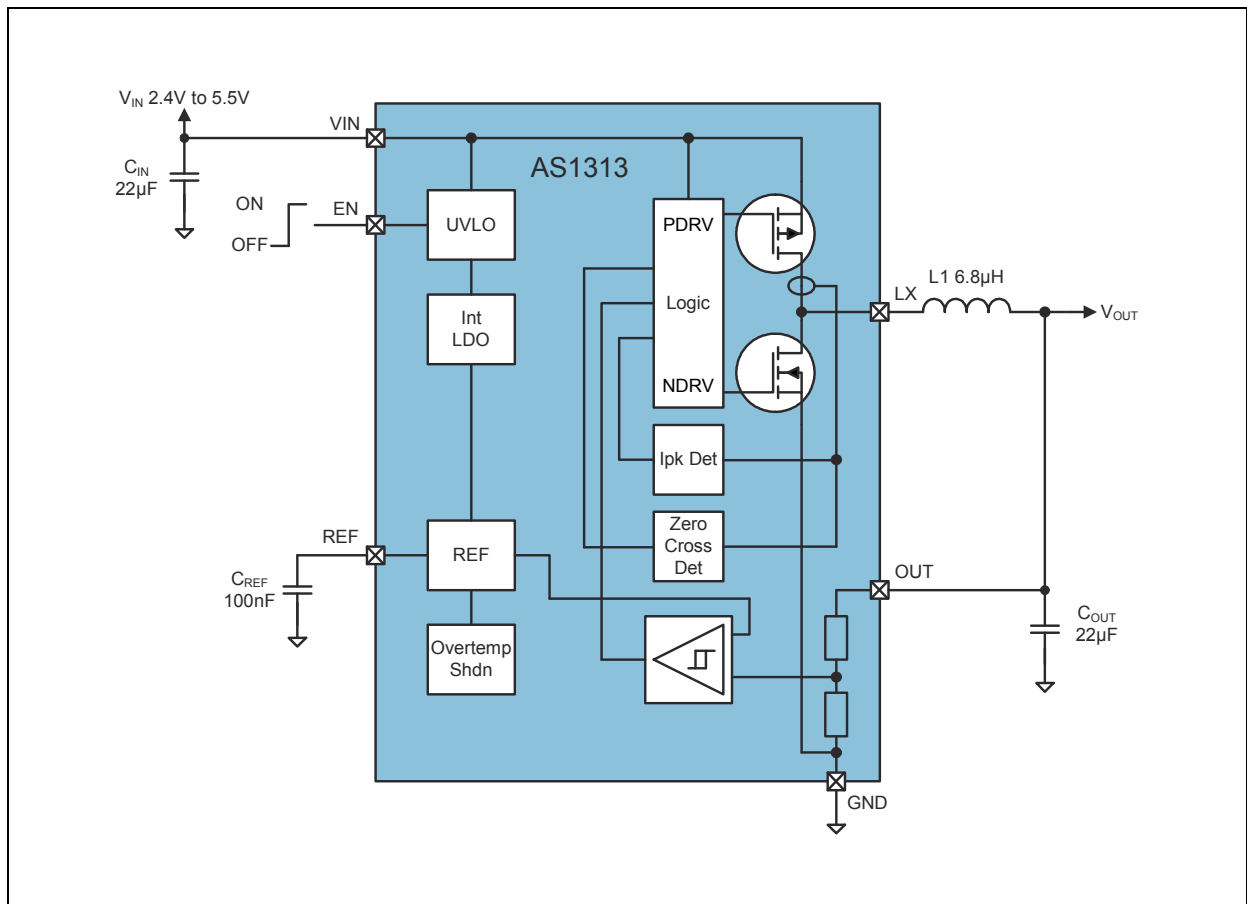

Pin Assignment

The AS1313 pin assignment is described below.

Figure 3:
Pin Assignment for MLPD and WL-CSP

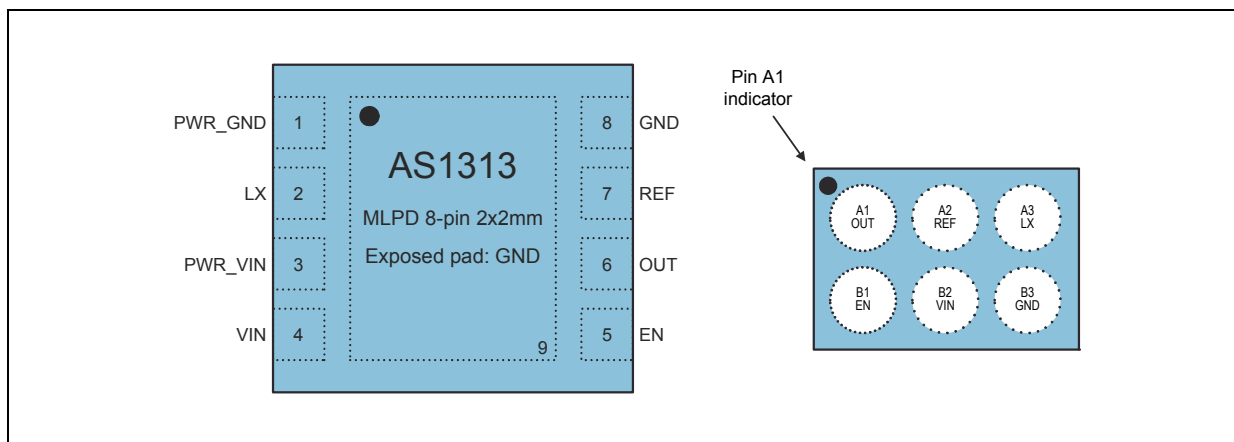

Pin Assignment: Shows the TOP view pin assignment of the AS1313.

Figure 4:
Pin Description

Pin Number		Pin Name	Pin Type	Description
MLPD	WL-CSP			
1	-	PWR_GND	GND	Ground. Connect to GND; only available in MLPD package
2	A3	LX	DO	Switch Node Connection to Coil. This pin connects to the drains of the internal main and synchronous power MOSFET switches.
3	-	PWR_VIN	S	Power Input Supply. Connect to VIN; only available in MLPD package
4	B2	VIN	S	Battery Voltage Input. Decouple VIN with a 22 μ F ceramic capacitor as close as possible to VIN and GND.
5	B1	EN	DI	Enable Input. Logic controlled shutdown input. ⁽¹⁾ 1 = Normal Operation 0 = Shutdown
6	A1	OUT	AI	Output Voltage. An internal resistor divider steps the output voltage down for comparison to the internal reference voltage.
7	A2	REF	AIO	Reference. Connect a 100nF capacitor to this pin
8	B3	GND	GND	Ground
9	-		GND	Exposed Pad. This pad is not connected internally. This pin also functions as a heat sink. Solder it to a large pad or to the circuit-board ground plane to maximize power dissipation.

Note(s) and/or Footnote(s):

1. This pin should not be left floating.

Absolute Maximum Ratings

Stresses beyond those listed under [Absolute Maximum Ratings](#) may cause permanent damage to the device. These are stress ratings only. Functional operation of the device at these or any other conditions beyond those indicated under [Electrical Characteristics](#) is not implied. Exposure to absolute maximum rating conditions for extended periods may affect device reliability.

Figure 5:
Absolute Maximum Ratings

Symbol	Parameter	Min	Max	Units	Comments
Electrical Parameters					
	Supply voltage to ground 5V pins	-0.3	7.0	V	Applicable for pins: VIN, PWR_VIN, VOUT, EN
	Supply voltage to ground 5V pins	-0.3	$V_{OUT} + 0.3$	V	Applicable for pins: LX, REF
	Voltage difference between ground terminals	-0.3	0.3	V	Applicable for pins: GND, PWR_GND, Exposed Pad
	Input current (latch-up immunity)	-100	100	mA	Norm: JEDEC JESD78
Electrostatic Discharge					
$V_{ESD-HBM}$	Human Body Model		± 2	kV	Norm: JEDEC JESD22-A114F

Symbol	Parameter	Min	Max	Units	Comments	
Temperature Ranges and Storage Conditions						
$\theta_{JA}^{(1)}$	Thermal resistance	WL-CSP		95	°C/W	
		MLPD		36	°C/W	
T_{AMB}	Operating temperature	-40	85	°C		
T_J	Junction temperature	WL-CSP		25	°C	
		MLPD		150	°C	
T_{STRG}	Storage temperature range	-55	125	°C		
T_{BODY}	Package body temperature	WL-CSP		260	°C	Norm IPC/JEDEC J-STD-020 ⁽²⁾
		MLPD				Norm IPC/JEDEC J-STD-020 ⁽²⁾ The lead for Pb-free leaded packages is matte tin (100% Sn)
RH_{NC}	Relative humidity non-condensing	5	85	%		
MSL	Moisture sensitivity level	WL-CSP	1			Represents an unlimited floor life time
		MLPD	1			Represents an unlimited floor life time

Note(s) and/or Footnote(s):

1. Junction-to-ambient thermal resistance is very dependent on application and board-layout. In situations where high maximum power dissipation exists, special attention must be paid to thermal dissipation during board design.
2. The reflow peak soldering temperature (body temperature) is specified according IPC/JEDEC J-STD-020 "Moisture/Reflow Sensitivity Classification for Nonhermetic Solid State Surface Mount Devices".

Electrical Characteristics

All limits are guaranteed. The parameters with min and max values are guaranteed with production tests or SQC (Statistical Quality Control) method.

Figure 6:
Electrical Characteristics

Symbol	Parameter	Conditions	Min	Typ	Max	Unit
V_{IN}	Input voltage	V_{IN}, PWR_VIN	2.4		5.5	V
V_{OUT}	Regulated output voltage	$3.6V \leq V_{IN} \leq 5.5V$ ($V_{IN} \geq V_{OUT} + 0.5V$)	1.2		3.6	V
		$2.4V < V_{IN} < 3.6V$	1.2		$V_{IN} - 0.5V$	V
V_{OUT_TOL}	Output voltage tolerance	$I_{OUT} = 10mA,$ $T_{AMB} = 25^{\circ}C$	-3		+3	%
		$I_{OUT} = 10mA$	-4		+4	%
I_Q	Quiescent current	$V_{OUT} = 1.03 \times V_{OUTNOM}$ no load, $T_{AMB} = 25^{\circ}C$	0.35	1	2	μA
I_{SHDN}	Shutdown current	$V_{EN} = 0V$ $T_{AMB} = 25^{\circ}C$			100	nA
LNR	Output voltage line regulation	$V_{in} = 2.4V$ to $5.5V$ $I_{OUT} = 100mA$		0.2		%/V
		$V_{in} = 3.5V$ to $5.5V$ $I_{OUT} = 100mA$		0.05		%/V
LDR	Output voltage load regulation	$I_{OUT} = 0$ to $100mA$		0.02		%/mA
I_{PK}	Peak coil current	$V_{IN} = 3V, T_{AMB} = 25^{\circ}C$ $V_{OUT} = 0.9 \times V_{OUTNOM}$		400		mA
I_{LOAD}	Load current	$V_{IN} \geq V_{OUT} + 0.5V$			150	mA
R_{PMOS}	P-Channel FET $R_{DS(ON)}$	$I_{LX} = 100mA$		0.4		Ω
R_{NMOS}	N-Channel FET $R_{DS(ON)}$	$I_{LX} = -100mA$		0.4		Ω

Symbol	Parameter	Conditions	Min	Typ	Max	Unit
I_{LX}	LX leakage	$V_{EN} = 0V$, $V_{LX} = 0V$ or $5V$		± 0.01		μA
V_{ENH}	logic threshold	pin EN	1.2			V
V_{ENL}					0.2	V
I_{EN}	EN input bias current	$EN = 3.6V$ $T_{AMB} = 25^{\circ}C$			100	nA
I_{REF}	REF input bias current	$REF = 0.99 \times V_{OUTNOM}$ $T_{AMB} = 25^{\circ}C$			100	nA
T_{SHDN}	Thermal shutdown			150		$^{\circ}C$
ΔT_{SHDN}	Thermal shutdown hysteresis			25		$^{\circ}C$

Electrical Characteristics: Shows the Electrical Characteristics of the DC-DC Converter. $V_{IN} = EN = 3.6V$, $T_{AMB} = -40^{\circ}C$ to $85^{\circ}C$ (unless otherwise specified).

Typical Operating Characteristics

Figure 7:
Efficiency vs. Output Current, $V_{OUT} = 1.8V$

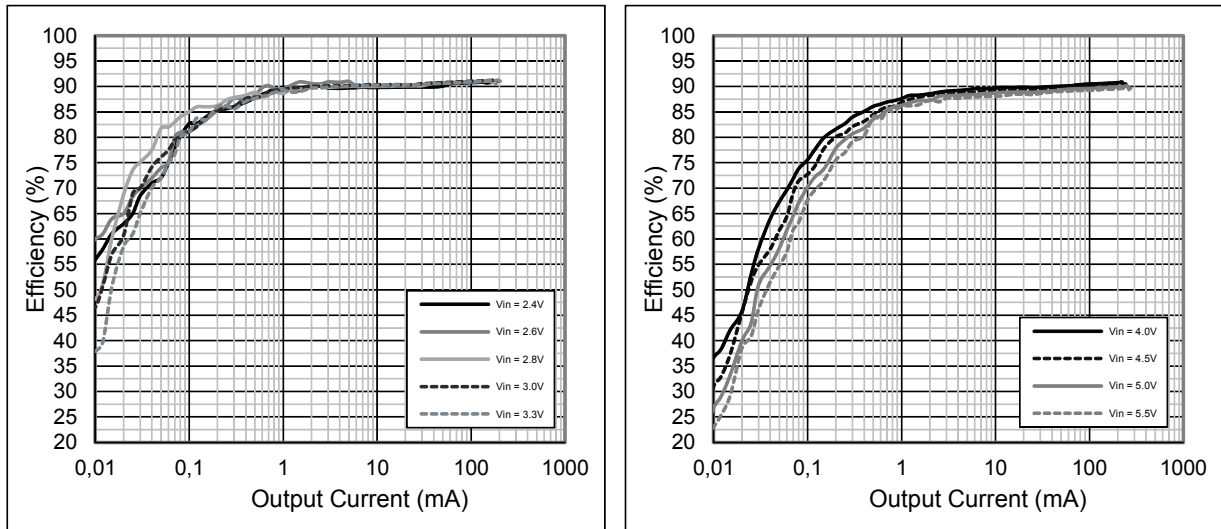

Efficiency vs. Output Current: These figures show the Efficiency vs. the Output Current for various Input Voltages. All measurements were done with $V_{OUT} = 1.8V$ at $T_{AMB} = 25^{\circ}C$ with the coil LPS4018-682.

Figure 8:
Efficiency vs. Output Current, $V_{OUT} = 3.0V$

Efficiency vs. Output Current: This figure shows the Efficiency vs. the Output Current for various Input Voltages. All measurements were done with $V_{OUT} = 3.0V$ at $T_{AMB} = 25^{\circ}C$ with the coil LPS4018-682.

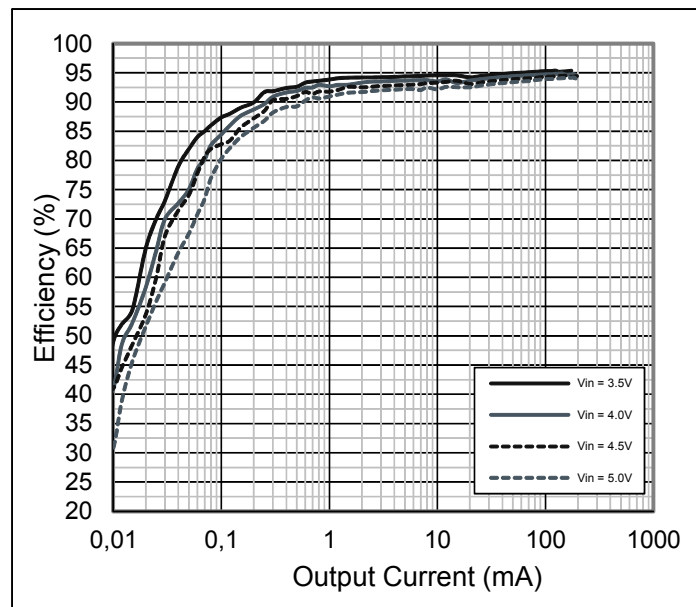

Figure 9:
Maximum Output Current vs. Input Voltage

Maximum Output Current vs. Input Voltage: This figure shows the I_{OUT_MAX} vs. the Input Voltage for $V_{OUT} = 1.8V$ and $V_{OUT} = 3.0V$ at $T_{AMB} = 25^{\circ}C$ with the coil LPS4018-682.

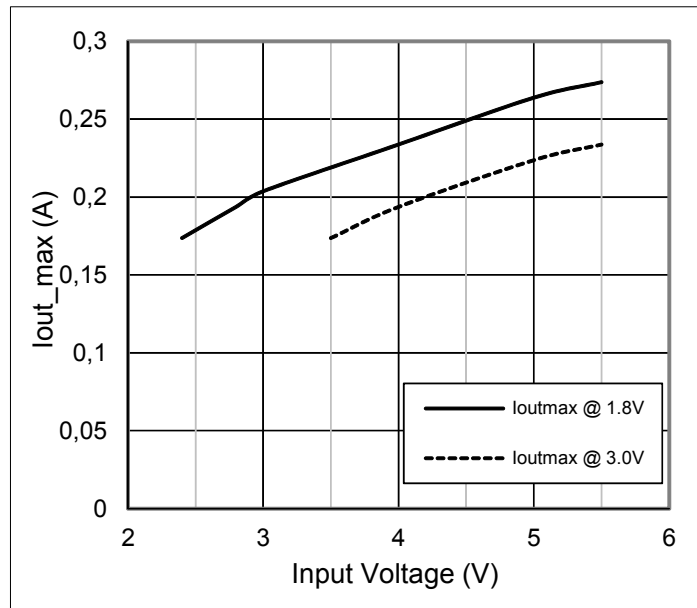

Figure 10:
Efficiency vs. Input Voltage, $V_{OUT} = 1.8V$

Efficiency vs. Input Voltage: This figure shows the Efficiency vs. the Input Voltage for various Output Currents. All measurements were done with a $V_{OUT} = 1.8V$ at $T_{AMB} = 25^{\circ}C$ with the coil LPS4018-682.

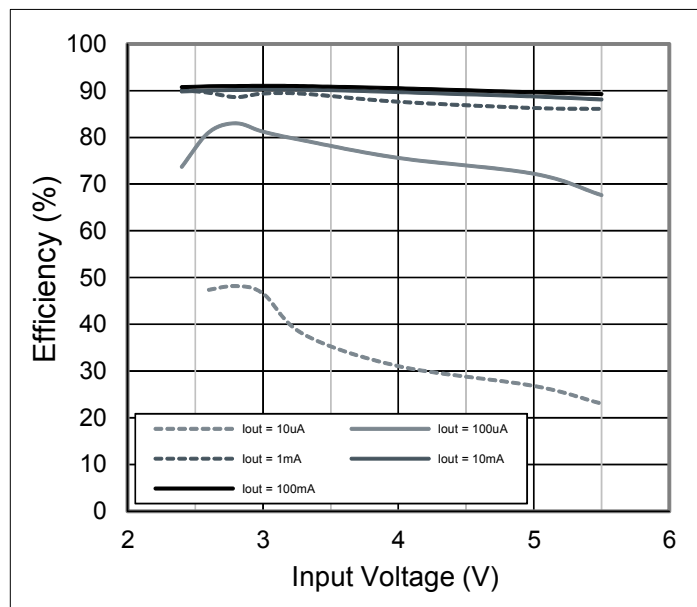

Figure 11:
Efficiency vs. Input Voltage, $V_{OUT} = 3.0V$

Efficiency vs. Input Voltage: This figure shows the Efficiency vs. the Input Voltage for various Output Currents. All measurements were done with a $V_{OUT} = 3.0V$ at $T_{AMB} = 25^{\circ}C$ with the coil LPS4018-682.

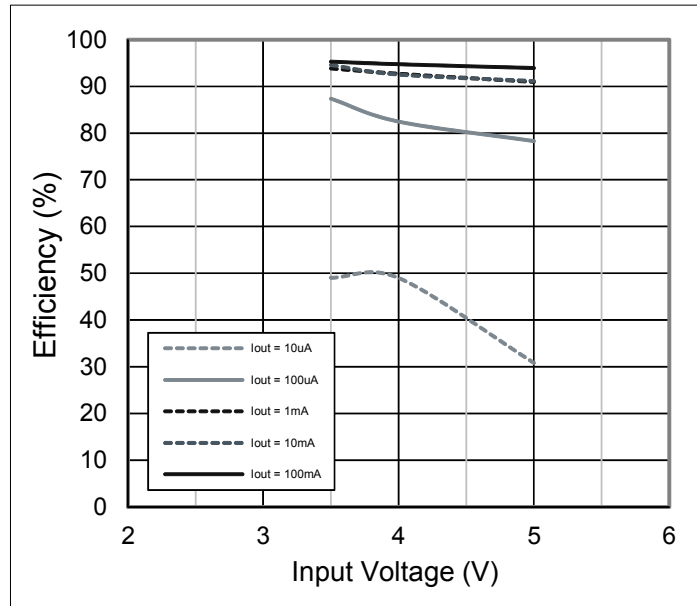
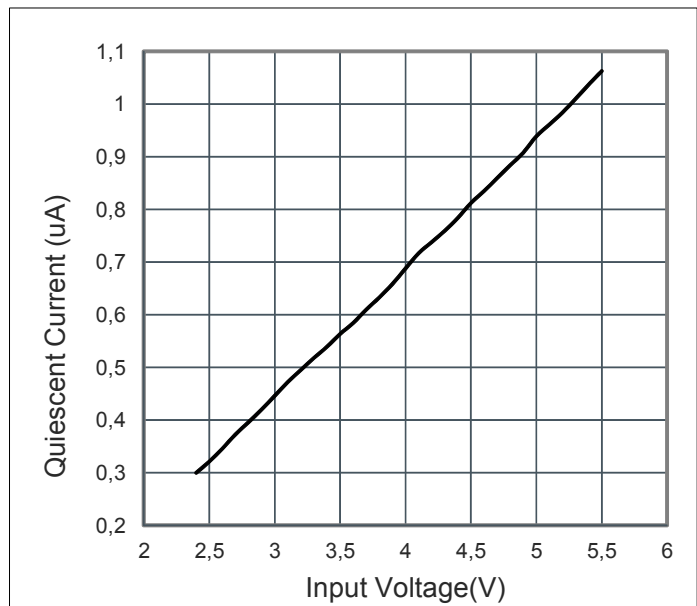

Figure 12:
Quiescent Current vs. Input Voltage, $V_{OUT} = 1.8V$

Quiescent Current vs. Input Voltage: This figure shows the Quiescent Current vs. the Input Voltage for $V_{OUT} = 1.8V$. The measurement was done at $T_{AMB} = 25^{\circ}C$ with the coil LPS4018-682.



Detailed Description

The AS1313 is a hysteretic converter and has no continuously operating fixed oscillator, providing an independent timing reference. This means the triggering of the on-off switching of the internal switches depends only on comparators measuring the output voltage and the coil current measurement. This leads to a very low quiescent current. In addition, because there is no fixed timing reference, the operating frequency is determined by external components (inductor and capacitors) and the loading on the output.

Ripple at the output is an essential operating behavior. A power cycle is initiated when the output regulated voltage drops below the nominal value of V_{OUT} .

Figure 13:
Simplified Synchronous Step-Down DC-DC Architecture

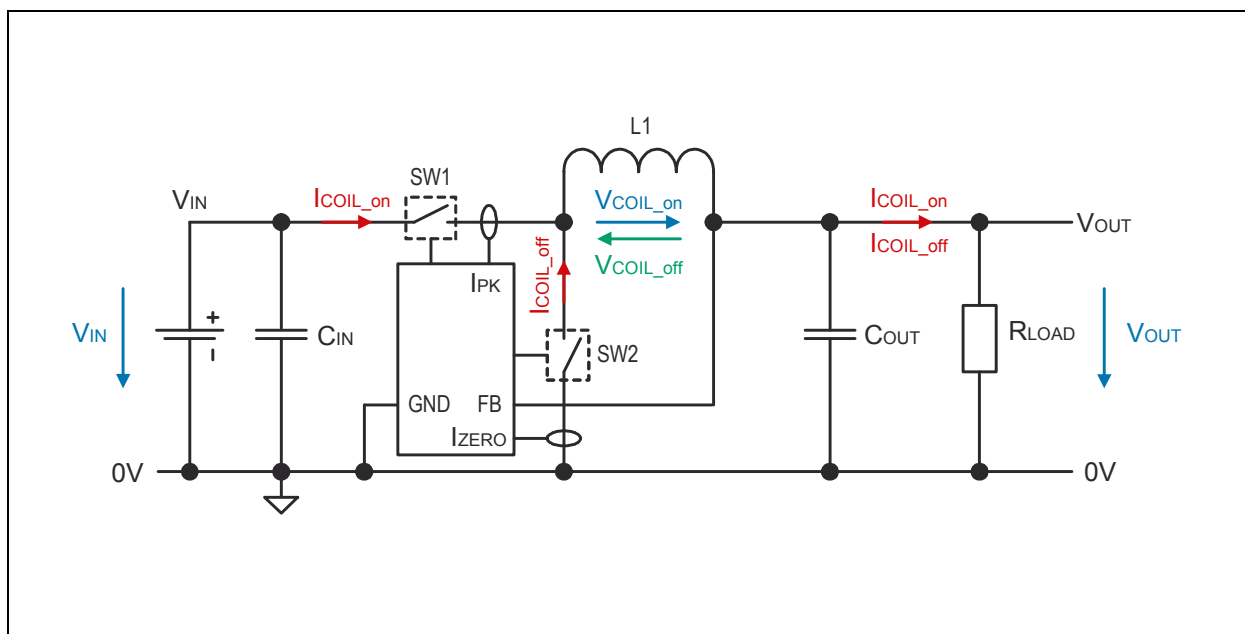

When SW1 is closed and SW2 is open, the current is flowing from V_{IN} through the coil to R_{LOAD} . With neglecting the resistive voltage drop over SW1 the voltage across the coil is:

$$V_{COIL_on} = V_{IN} - V_{OUT}$$

Based on the expression, which shows the correlation between voltage across the coil and the coil current, it's easy to rearrange this equation to get the coil current I_{COIL} generated while SW1 is closed (t_{ON}).

$$(EQ1) \quad u = L \frac{di}{dt} \Rightarrow I_{COIL} = \left(\frac{V_{IN} - V_{OUT}}{L} \cdot t_{ON} \right)$$

When SW1 is open and SW2 is closed, the coil gets discharged, works like a voltage supply and forces the current through R_{LOAD} and SW2. With neglecting the resistive voltage drop over SW2 the voltage across the coil is:

$$V_{COIL-off} = V_{OUT}$$

Similar to the expression above, the I_{COIL} generated while SW2 is closed (t_{OFF}) can be expressed as:

$$(EQ2) \quad I_{COIL} = \frac{V_{OUT}}{L} \cdot t_{OFF}$$

The increasing coil current during the charging (SW1 closed) and the decreasing coil current during the discharging of the coil (SW2 closed) must be the same. Hence, it's easy to calculate the duty cycle of SW1.

$$(EQ3) \quad I_{COIL} = \frac{V_{IN} - V_{OUT}}{L} \cdot t_{ON} = \left(\frac{V_{OUT}}{L} \cdot t_{OFF} \right) \Rightarrow \left(\frac{V_{OUT}}{V_{IN}} = \frac{t_{ON}}{t_{ON} + t_{OFF}} \right)$$

Based on the EQ1, the on time of SW1 can be given by:

$$(EQ4) \quad t_{ON} = \frac{L}{V_{IN} - V_{OUT}} \cdot I_{COIL}$$

Figure 14:
Simplified Voltage and Current Diagram

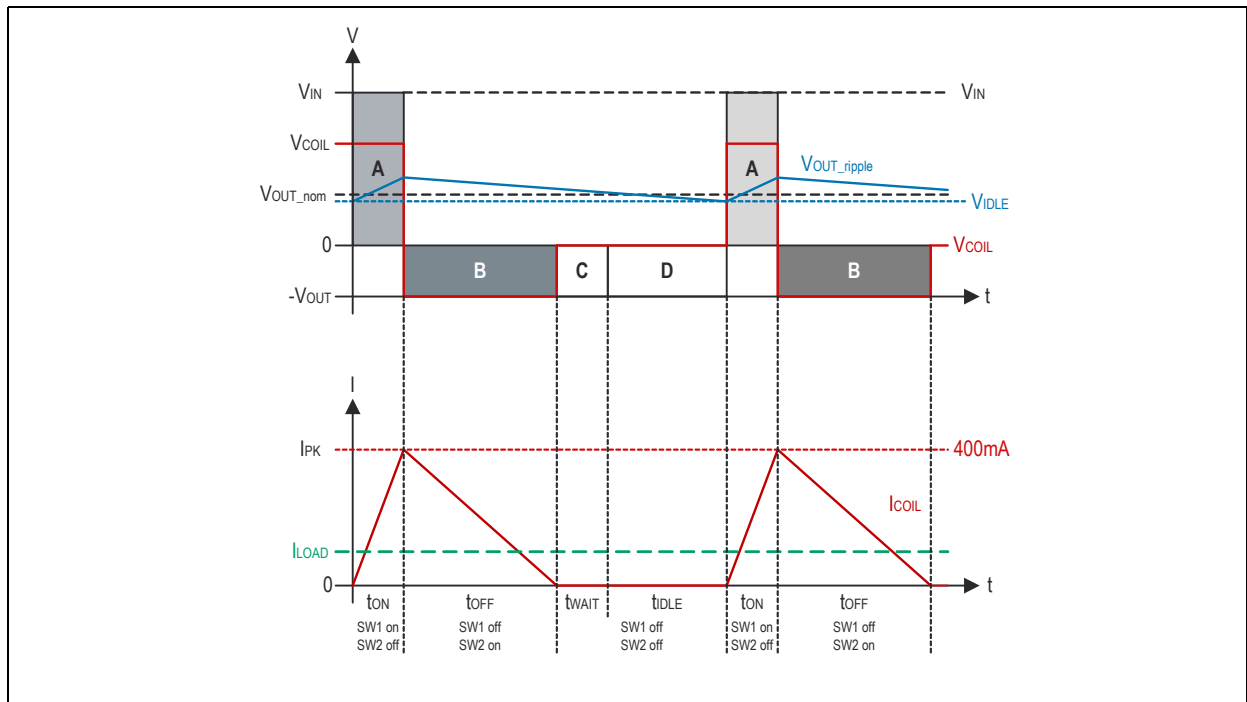

Timing Diagram: This figure shows the relationship between the current and the voltages inside the loop within the switching cycle.

If the V_{OUT} falls below the V_{OUT_nom} , SW1 closes and the coil current increases until the max. coil current of 400mA is reached. During this time t_{ON} , the V_{OUT} increases. With reaching the 400mA, the switch SW1 opens immediately, the SW2 closes and the coil current decreases down till it reaches the zero line. After this, SW2 opens and if the V_{OUT} is then above the V_{OUT_nom} , no further pulse is needed, both switches remain in their open position, hence no coil current is flowing. In this phase the needed output power only comes out of the C_{OUT} . This time is called t_{WAIT} , which takes $\sim 100\mu s$. If the V_{OUT} falls below V_{OUT_nom} within the time t_{WAIT} , the SW1 closes and the charging cycle starts again.

If the V_{OUT} is still higher than V_{OUT_nom} after t_{WAIT} is elapsed, then the AS1313 falls into an idle mode, which results in a reduction of the quiescent current. Once, the AS1313 is in this idle mode, the idle-comparator is comparing V_{OUT} with V_{IDLE} (98% of V_{OUT_nom}) and SW1 closes as soon as the V_{OUT} reaches this threshold.

External Component Selection

Inductors

For best efficiency, choose an inductor with high frequency core material, such as ferrite, to reduce core losses. The inductor should have low DCR (DC resistance) to reduce the I^2R losses, and must be able to handle the peak inductor current without saturating. A 6.8 μ H inductor with at least 500mA current rating and DCR of 500m Ω (max) is recommended.

Figure 15:
Recommended Inductors

Part Number	L	DCR	Current Rating	Size in mm (L/W/H)	Manufacturer
ELLVEG6R8N	6.8 μ H	0.35 Ω	0.58A	3x3x1	Panasonic www.industrial.panasonic.com
ELLVFG6R8MC	6.8 μ H	0.23 Ω	0.6A	3x3x1.2	
ELLVGG6R8N	6.8 μ H	0.23 Ω	1A	3x3x1.5	
LQH3NPN6R8MM0	6.8 μ H	0.24 Ω	1A	3x3x1.4	Murata www.murata.com
LQH3NPN6R8NM0	6.8 μ H	0.24 Ω	1A	3x3x1.4	
LQH3NPN6R8MJ0	6.8 μ H	0.252 Ω	0.85A	3x3x1.1	
LQH3NPN6R8NJ0	6.8 μ H	0.252 Ω	0.85A	3x3x1.1	
LQH3NPN6R8MMR	6.8 μ H	0.186 Ω	1.25A	3x3x1.1	
VLS2012ET-6R8M	6.8 μ H	0.498	0.57A	2x2x1.2	TDK www.tdk.com
VLS252015ET-6R8M	6.8 μ H	0.48	0.85A	2.5x2x1.5	
VLS3010ET-6R8M	6.8 μ H	0.312	0.69A	3x3x1	
VLS3012ET-6R8M	6.8 μ H	0.228	0.81A	3x3x1.2	
VLS3015ET-6R8M	6.8 μ H	0.216	0.92A	3x3x1.5	
LPS4018-682ML	6.8 μ H	0.15	1.2A	4x4x1.7	Coilcraft www.coilcraft.com

Capacitors

The AS1313 requires 3 capacitors. Recommended ceramic X5R or X7R types will minimize ESL and ESR while maintaining capacitance at rated voltage over temperature.

The input capacitor supports the triangular current during the on-time of SW1 and maintains a broadly constant input voltage during this time. The capacitance value is obtained from choosing a ripple voltage during the on-time of SW1.

$$(EQ5) \quad C_{IN} = \frac{I_{COIL}}{V_{RIPPLE}} \cdot t_{ON}$$

Using $t_{ON} = 1\mu s$, $I_{COIL} = 400mA$ and $V_{RIPPLE} = 50mV$, EQ5 yields:

$$C_{IN} = 8\mu F.$$

Because ceramic capacitors lose a lot of their initial capacitance at their maximum rated voltage, it is recommended that either a higher input capacity or a capacitance with a higher rated voltage is used. A $22\mu F$ cap for C_{IN} is recommended.

Additionally, ripple voltage is generated by the equivalent series resistance (ESR) of the capacitor.

$$(EQ6) \quad V_{RIPPLE_ESR} = I_{COIL} \cdot R_{ESR}$$

The output capacitor supports the triangular current during the off-time SW1 (coil discharge period), and also the load current during the wait time (Region C) and the idle time (Region D).

$$(EQ7) \quad C_{OUT} = \frac{I_{OUT}}{0.02 \cdot V_{OUT_nom}} \cdot (t_{WAIT} + t_{IDLE})$$

Using $t_{WAIT} = 100\mu s$, $t_{IDLE} = 500\mu s$, $I_{OUT} = 1mA$ and $V_{OUT_nom} = 3.3V$, EQ7 yields:

$$C_{OUT} = 9\mu F.$$

Due to the DC bias of the cap and to sustain also load steps, the C_{OUT} should be between $22\mu F$ and $47\mu F$. A larger output capacitor should be used if lower peak to peak output voltage ripple is desired. A larger output capacitor will also improve load regulation on V_{OUT} .

Figure 16:
Recommended Input & Output Capacitors

Part Number	C	TC Code	Voltage Rating	Size in mm (L/W/H)	Manufacturer
GRM21BR60J226ME39L	22 μ F	X5R	6.3V	2x1.25x1.25	Murata www.murata.com
GRM31CR61A226ME19L	22 μ F	X5R	10V	3.2x1.6x1.6	
12066D226KAT_A	22 μ F	X5R	6.3V	3.2x1.6x1.78	AVX www.avx.com
1210ZD226KAT_A	22 μ F	X5R	10V	3.2x1.6x1.78	
1210YD226KAT_A	22 μ F	X5R	16V	3.2x1.6x1.78	
C2012X5R0J226K/1.25	22 μ F	X5R	6.3V	2x1.2x1.25	TDK www.tdk.com
C2012X5R1A226K/1.25	22 μ F	X5R	10V	2x1.2x1.25	
C2012X5R1C226K	22 μ F	X5R	16V	2x1.2x1.25	

For C_{REF} a 100nF cap (X5R or better) is recommended.

Application Information

The AS1313 is an ideal solution for Li-ion and coin cell powered devices as blood glucose meters, remote controls, hearing aids, wireless mouse or any light-load application.

Figure 17:
Typical Application Circuit

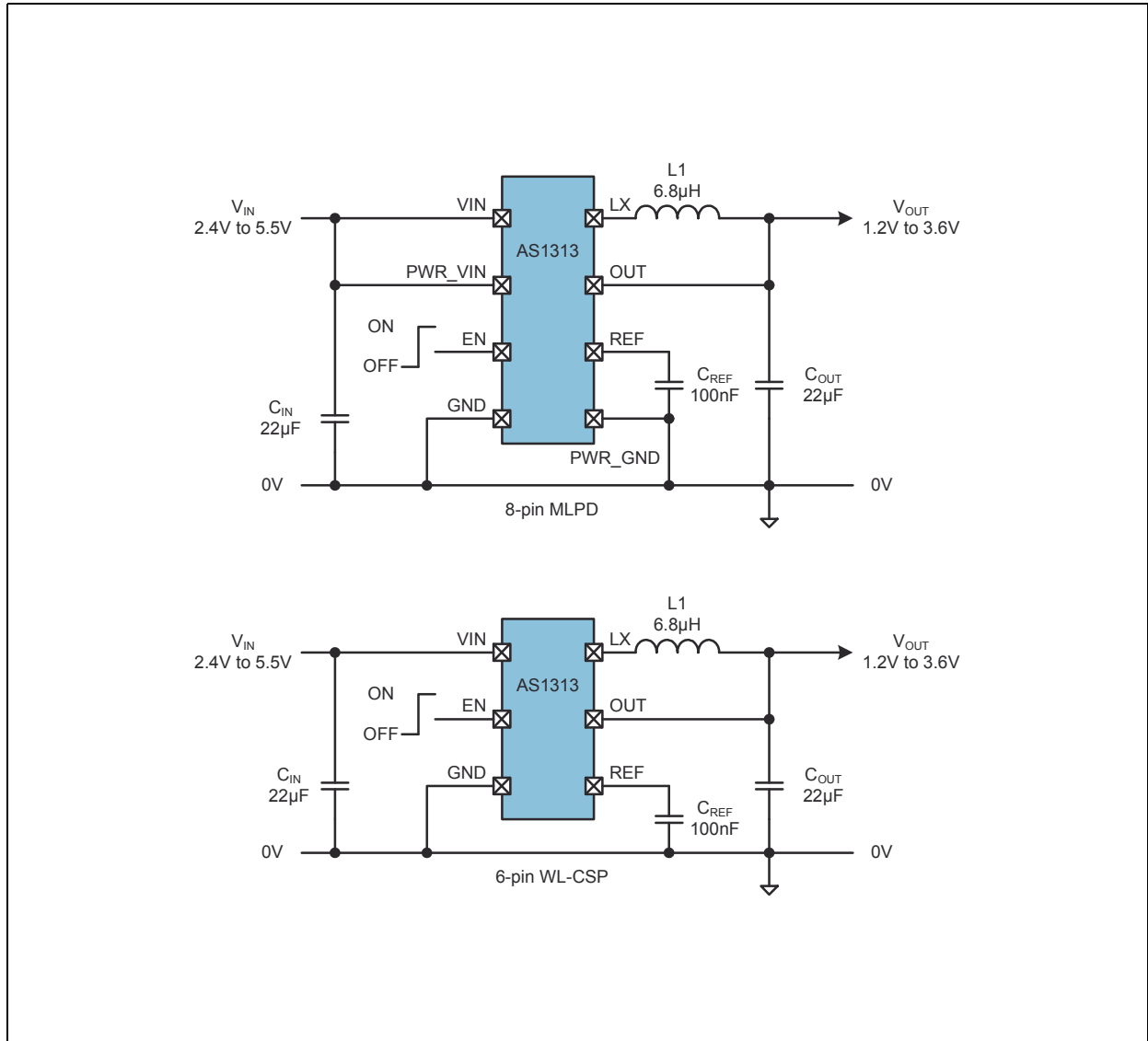

Typical Application: This figure shows the typical application of the DC-DC Step Down Converter for 8-pin MLPD package and 6-pin WL-CSP.

Package Drawings & Markings

Figure 18:
MLPD-8 2x2 0.5mm Pitch Package Drawing

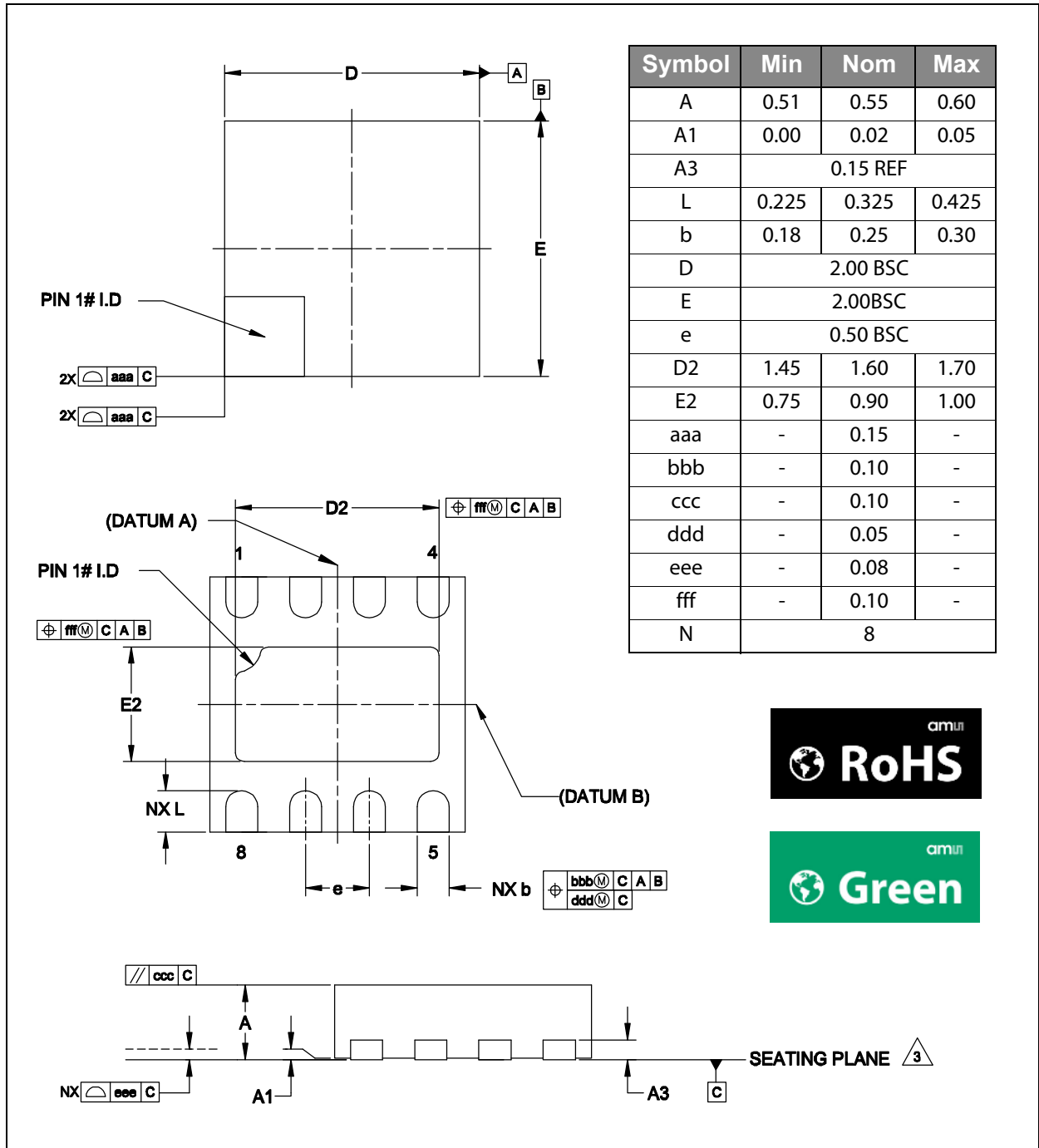

Note(s) and/or Footnote(s):

1. Dimensioning and tolerancing conform to ASME Y14.5M-1994.
2. All dimensions are in millimeters. Angles are in degrees.
3. Coplanarity applies to the exposed heat slug as well as the terminal.
4. Radius on terminal is optional.
5. N is the total number of terminals.

Figure 19:
WL-CSP6 0.4mm Pitch Package Drawing

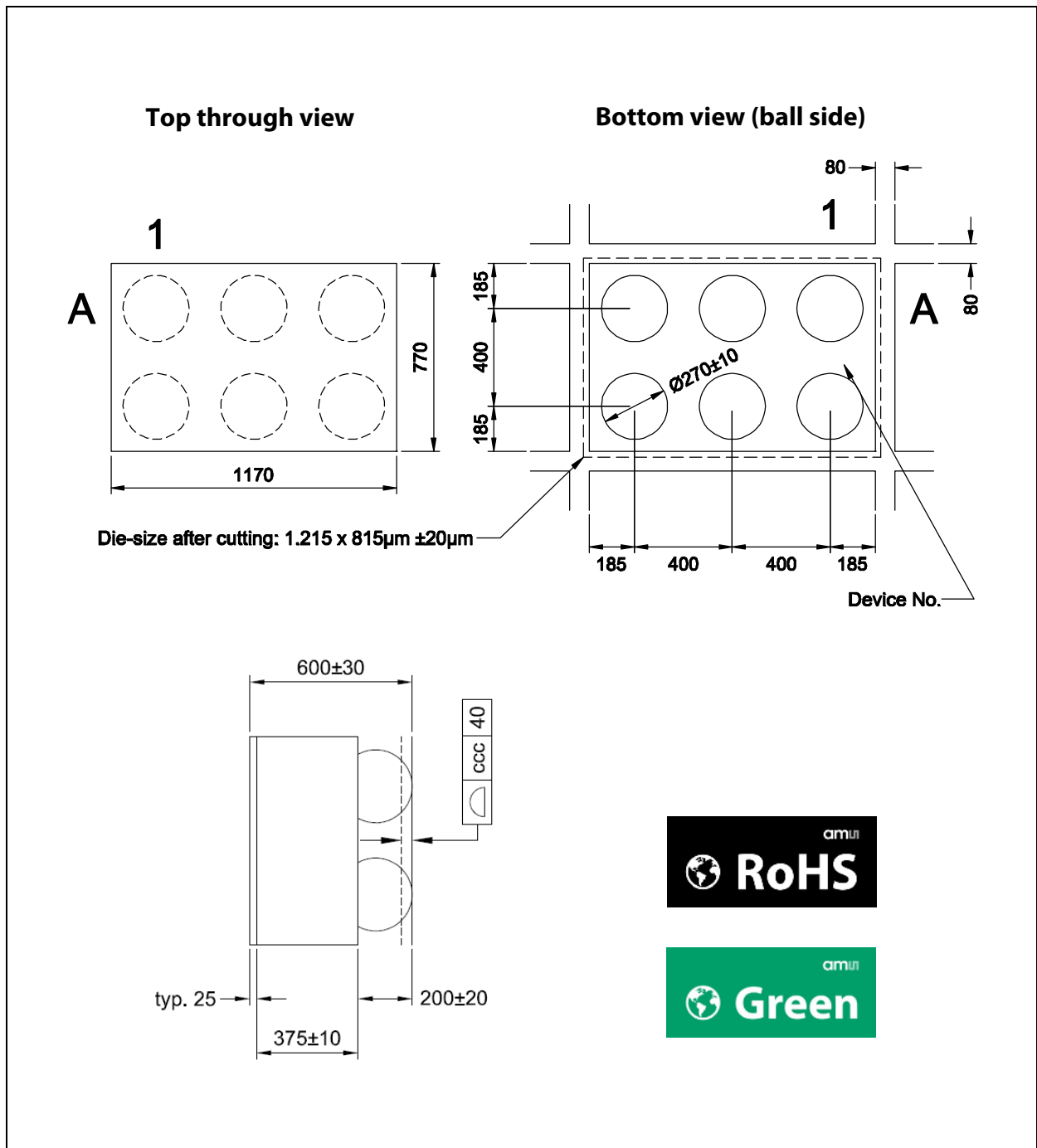

Note(s) and/or Footnote(s):

1. ccc Coplanarity.
2. All dimensions are in μm .



Figure 20:
MLPD and WL-CSP Markings

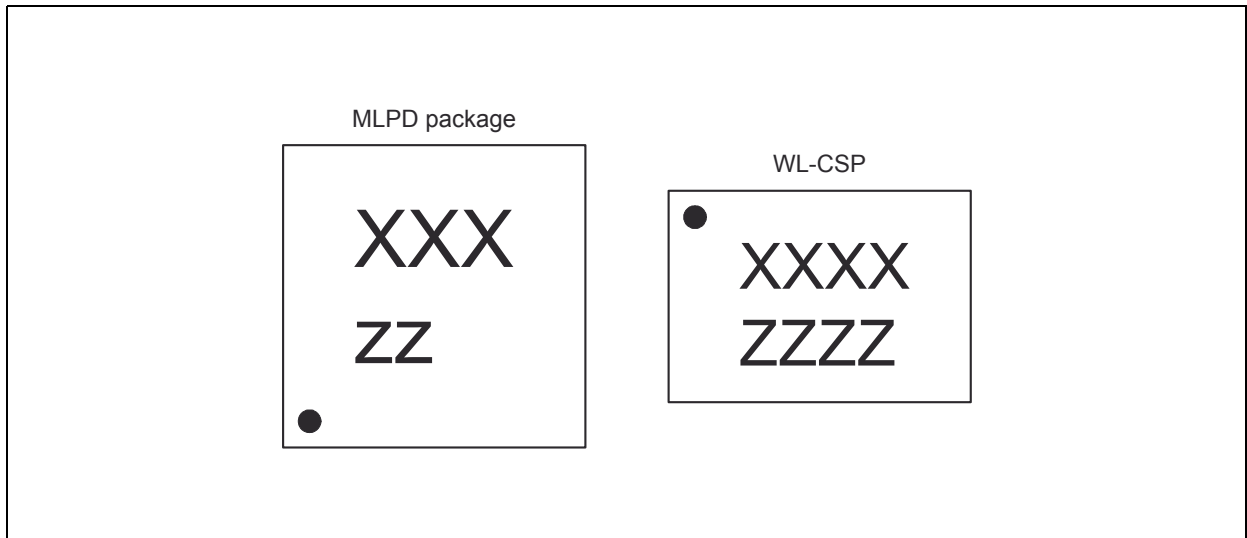

AS1313 Marking: Shows the package marking of the MLPD and the WL-CSP product version

Figure 21:
Package Codes

XXXX	XXX	ZZ	ZZZZ
Trace Code for WL-CSP	Trace Code for MLPD	Marking Code for MLPD	Marking Code for WL-CSP

Package Codes: Shows the package codes of the MLPD and WL-CSP product versions.

Ordering & Contact Information

Figure 22:
Ordering Information

Ordering Code	Marking	Output	Package	Delivery Form	Delivery Quantity
AS1313-BTDM-18	BT	1.8V	MLPD-8lead (2mm x 2mm)	Tape & Reel	1000
AS1313-BTDM-30	BV	3.0V	MLPD-8lead (2mm x 2mm)	Tape & Reel	1000
AS1313-BTDM-33	BU	3.3V	MLPD-8lead (2mm x 2mm)	Tape & Reel	1000
AS1313-BTDT-ES	ES	Engineering sample	MLPD-8lead (2mm x 2mm)	Tray	see note (1)
AS1313-BWLT-ES	ASU8	Engineering sample	6-pin WL-CSP 0.4mm pitch	Tray	see note (1)
AS1313-BWLT-12	ASU9	1.2V	6-pin WL-CSP 0.4mm pitch	Tape & Reel	10000

Note(s) and/or Footnote(s):

1. Engineering sample quantities are according to customer needs.

Buy our products or get free samples online at:

www.ams.com/ICdirect

Technical Support is available at:

www.ams.com/Technical-Support

Provide feedback about this document at:

www.ams.com/Document-Feedback

For further information and requests, e-mail us at:

ams_sales@ams.com

For sales offices, distributors and representatives, please visit:

www.ams.com/contact

Headquarters

ams AG
Tobelbaderstrasse 30
8141 Unterpremstaetten
Austria, Europe

Tel: +43 (0) 3136 500 0

Website: www.ams.com

RoHS Compliant & ams Green Statement

RoHS: The term RoHS compliant means that ams AG products fully comply with current RoHS directives. Our semiconductor products do not contain any chemicals for all 6 substance categories, including the requirement that lead not exceed 0.1% by weight in homogeneous materials. Where designed to be soldered at high temperatures, RoHS compliant products are suitable for use in specified lead-free processes.

ams Green (RoHS compliant and no Sb/Br): ams Green defines that in addition to RoHS compliance, our products are free of Bromine (Br) and Antimony (Sb) based flame retardants (Br or Sb do not exceed 0.1% by weight in homogeneous material).

Important Information: The information provided in this statement represents ams AG knowledge and belief as of the date that it is provided. ams AG bases its knowledge and belief on information provided by third parties, and makes no representation or warranty as to the accuracy of such information. Efforts are underway to better integrate information from third parties. ams AG has taken and continues to take reasonable steps to provide representative and accurate information but may not have conducted destructive testing or chemical analysis on incoming materials and chemicals. ams AG and ams AG suppliers consider certain information to be proprietary, and thus CAS numbers and other limited information may not be available for release.

Copyrights & Disclaimer

Copyright ams AG, Tobelbader Strasse 30, 8141 Unterpremstaetten, Austria-Europe. Trademarks Registered. All rights reserved. The material herein may not be reproduced, adapted, merged, translated, stored, or used without the prior written consent of the copyright owner.

Devices sold by ams AG are covered by the warranty and patent indemnification provisions appearing in its General Terms of Trade. ams AG makes no warranty, express, statutory, implied, or by description regarding the information set forth herein. ams AG reserves the right to change specifications and prices at any time and without notice. Therefore, prior to designing this product into a system, it is necessary to check with ams AG for current information. This product is intended for use in commercial applications. Applications requiring extended temperature range, unusual environmental requirements, or high reliability applications, such as military, medical life-support or life-sustaining equipment are specifically not recommended without additional processing by ams AG for each application. This product is provided by ams AG "AS IS" and any express or implied warranties, including, but not limited to the implied warranties of merchantability and fitness for a particular purpose are disclaimed.

ams AG shall not be liable to recipient or any third party for any damages, including but not limited to personal injury, property damage, loss of profits, loss of use, interruption of business or indirect, special, incidental or consequential damages, of any kind, in connection with or arising out of the furnishing, performance or use of the technical data herein. No obligation or liability to recipient or any third party shall arise or flow out of ams AG rendering of technical or other services.

Document Status

Document Status	Product Status	Definition
Product Preview	Pre-Development	Information in this datasheet is based on product ideas in the planning phase of development. All specifications are design goals without any warranty and are subject to change without notice
Preliminary Datasheet	Pre-Production	Information in this datasheet is based on products in the design, validation or qualification phase of development. The performance and parameters shown in this document are preliminary without any warranty and are subject to change without notice
Datasheet	Production	Information in this datasheet is based on products in ramp-up to full production or full production which conform to specifications in accordance with the terms of ams AG standard warranty as given in the General Terms of Trade
Datasheet (discontinued)	Discontinued	Information in this datasheet is based on products which conform to specifications in accordance with the terms of ams AG standard warranty as given in the General Terms of Trade, but these products have been superseded and should not be used for new designs

Revision Information

Changes from 1-41 (2013-Oct) to current revision 1-43 (2015-Jul-21)	Page
1-41 (2013-Oct) to 1-42 (2014-Jun-12)	
Content was updated to the latest ams design	
Updated Figure 22	21
1-42 (2014-Jun-12) to 1-43 (2015-Jul-23)	
Content was updated to the latest ams design	
Updated Figure 21	20
Updated Figure 22	21

Note(s) and/or Footnote(s):

1. Page and figure numbers for the previous version may differ from page and figure numbers in the current revision.
2. Correction of typographical errors is not explicitly mentioned.

Content Guide

1	General Description
1	Key Benefits & Features
2	Applications
2	Block Diagram
3	Pin Assignment
4	Absolute Maximum Ratings
6	Electrical Characteristics
8	Typical Operating Characteristics
11	Detailed Description
14	External Component Selection
14	Inductors
15	Capacitors
17	Application Information
18	Package Drawings & Markings
21	Ordering & Contact Information
22	RoHS Compliant & ams Green Statement
23	Copyrights & Disclaimer
24	Document Status
25	Revision Information