



PART NAME

PIP SERIES - PC 10% FIBERGLASS BOX

PART No.

PIP-11763

PIP-11763-C

REVISION DATE

12-3-15

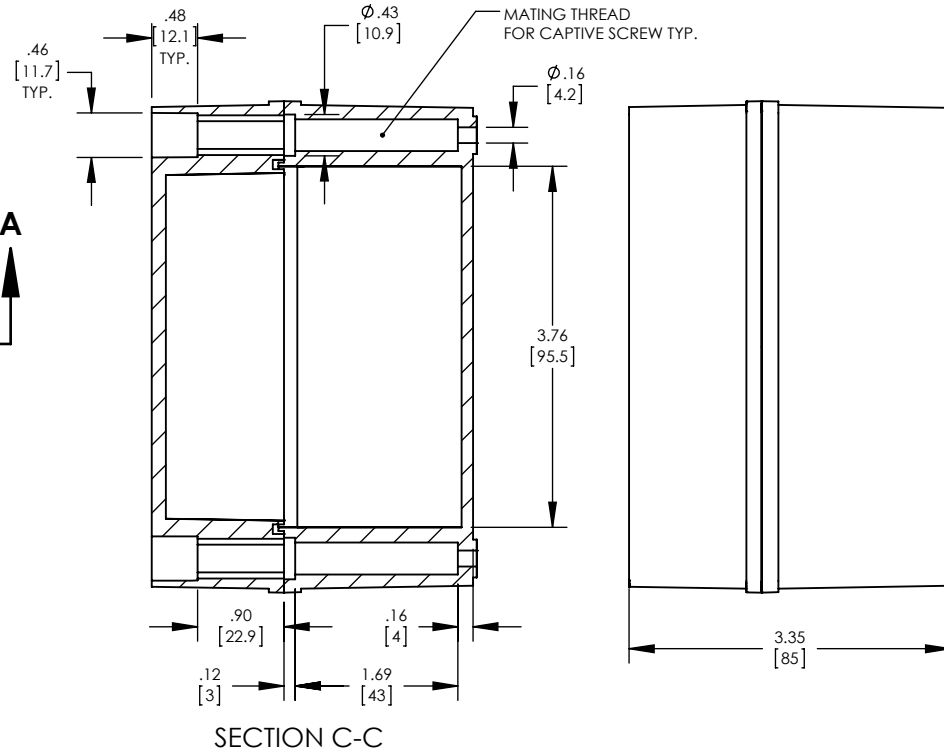
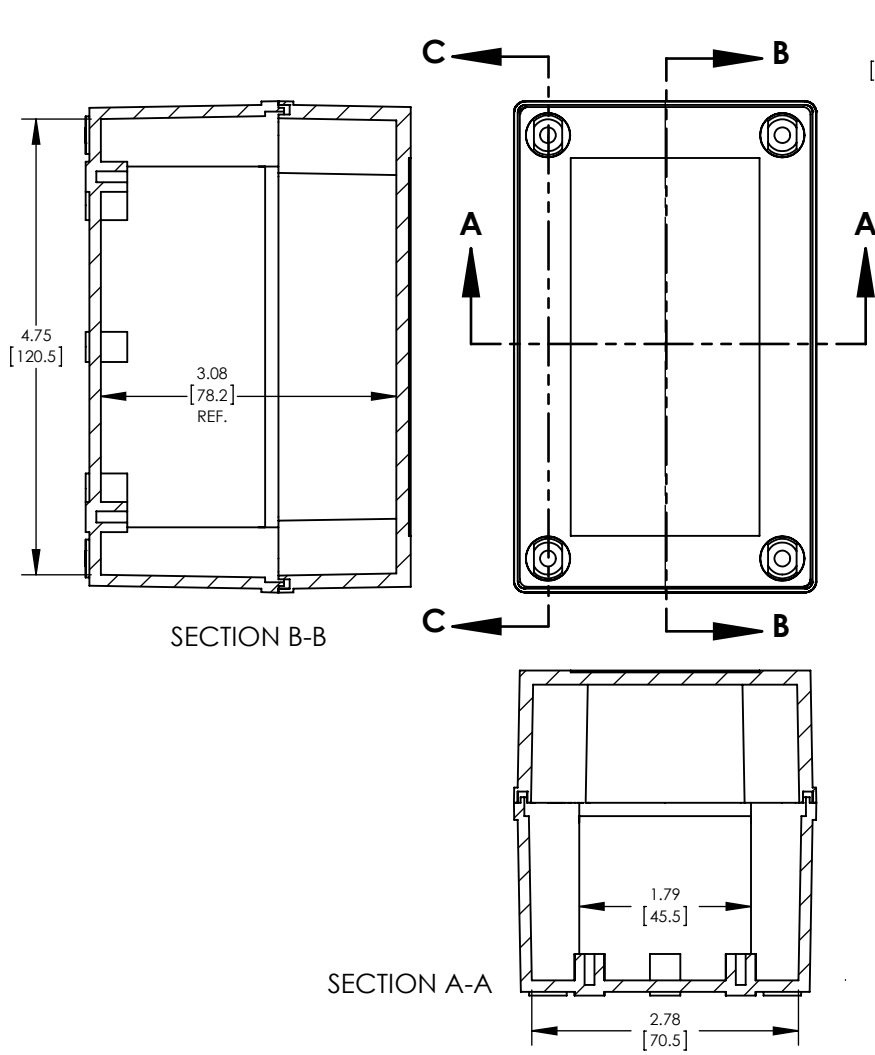

- NOTES:
- 1- MATERIAL: BODY - POLYCARBONATE 10% FIBERGLASS REINFORCED
COVER - POLYCARBONATE
UL508 /NEMA TYPE 4X WITH IP-67 TUV RATING & UL-94V0 RATING
 - 2- FINISH: BODY - LIGHT GRAY
COVER - LIGHT GRAY OR CLEAR (-C)
 - 3- SUPPLIED WITH FOUR NON-METALLIC CAPTIVE SCREWS FOR COVER MOUNTING
 - 4- CONTINUOUS GASKET IN COVER
 - 5- SUPPLIED WITH FOUR M4 x 8mm LG. TRUSS HEAD MACHINE SCREWS
 - 6- DIMENSIONS ARE INCH [MM]
 - 7- DRAWING FOR REFERENCE
 - 8- OPTIONAL ACCESSORIES:
INTERNAL STEEL PANEL - #PIX-11760
MOUNTING BRACKET KIT (STAINLESS STEEL) - #NBX-10922
MOUNTING BRACKET KIT (PLASTIC) - #PIX-4117

