

INDUCTIVE LOAD SUPPRESSOR

DESCRIPTION

These devices, when installed across an inductive load, such as a contactor, solenoid or relay, will suppress transient surges during a switching. This will enhance relay life and provide increased reliability of operation.

There are two devices available, one for use in 115 volt circuits and one for use in 230 volt circuits.

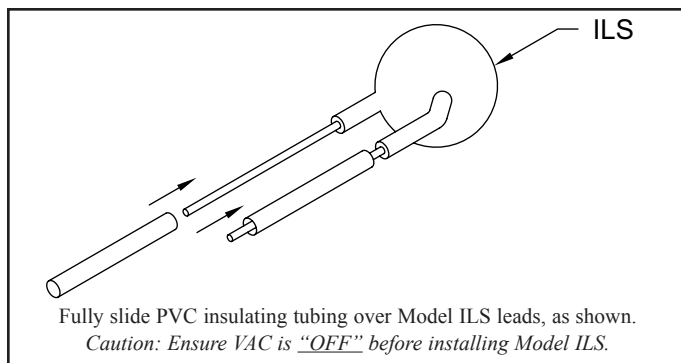
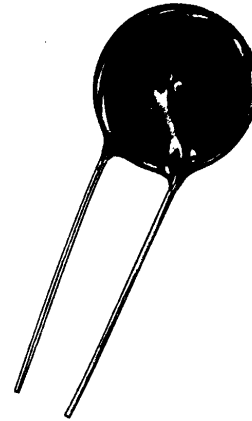

ORDERING INFORMATION

MODEL NO.	DESCRIPTION	PART NUMBER
ILS1	115 VAC Inductive Load Suppressor	ILS11500
ILS2	230 VAC Inductive Load Suppressor	ILS23000

ILS SPECIFICATIONS *

DEVICE MODEL NUMBER	RATED VOLTAGE		RATED PEAK SINGLE PULSE TRANSIENT CURRENT (AMPS)	SINGLE PULSE TRANSIENT ENERGY JOULES	POWER DISSIPATION WATTS	CLAMPING VOLTAGE VOLTS
	AC VOLTS	DC VOLTS				
ILS1	130	175	6500	80	1.0	340 V @ 100 A
ILS2	275	370	6500	150	1.0	710 V @ 100 A

*NOTE: These devices will suppress most transient surges. However, if the device heats up or stops functioning after a short period of time a higher joules rated device may be required.



Do not dispose of unit in trash - Recycle

INSTALLATION CONSIDERATIONS OF ELECTRONIC INSTRUMENTS & CONTROLS, IN INDUSTRIAL ENVIRONMENTS

Most electronic equipment designed for use in industrial environments has a high degree of noise immunity and protection against damage. But even the best can experience difficulties in operation if certain minimal considerations are not adhered to when installing the equipment. When relay contacts are used to switch inductive loads, such as auxiliary relays or solenoids, extremely large voltage spikes can be generated when the relay contact opens, these voltage spikes can cause pitting of the relay's contacts, thereby reducing its usable life.

The internal functioning components of an electronic instrument operate on a low DC voltage, generally 5 V, and respond to signals as low as 1 V or less. In contrast, stray voltage spikes in excess of 100 V and sometimes thousands of volts can be detected in the industrial environment. These voltage spikes can be coupled from power lines that are powering equipment that contains S.C.R. circuitry, or in other ways causes rapid load changes on the AC line. These spikes can also be coupled from lines that are actuating AC or DC solenoids or actuators. In other words, any wiring in an industrial application should be considered a potential noise source.

How can these noise spikes get into the instrument? There are three major ways that noise spikes can enter the instrument.

1. Noise can enter directly, via the AC power input. It is recommended that electronic instruments be connected to a relatively clean source of power. If this cannot be accomplished, there are means of suppressing noise or isolating the instrument from the noise. These consist of everything from simple inductive load suppressors (M.O.V.'s) to constant voltage isolation transformers, depending on the severity of power line disturbance.
2. Noise can enter via the input leads. Here, there are two modes (See Fig. 1) by which the noise can enter. Normal mode, which means the noise enters on the input lead, with respect to the instrument common; and common mode, which means the noise enters on both the input and the instrument common with respect to earth ground (power line neutral). It is recommended that sensor input and control input wiring not be run in the same conduit or raceways with power lines or current carrying control lines. It is also recommended that these lines be kept away from inductive loads such as motors, solenoids, relays and contactors. For best results, it is recommended that two-conductor shielded cable be used to connect these inputs. The shield should be connected to the input common at the instrument only. In addition, the input common should only be connected to machine ground (earth) at one point, preferably a direct connection to the input common terminal.
3. The third way noise can enter the instrument is via the output lines. This is one of the most overlooked sources of trouble. When an output is driving an inductive load, such as solenoids, contactors, or relays; a large noise spike, several times the supply voltage, is generated every time the output is turned

off. This noise spike, in addition to physically degrading the relay contact, can radiate off the output lines and into more sensitive areas of the instrument. The surest way to alleviate this situation is to suppress the noise spike. It is best to do it at the noise source (See Fig. 2), to prevent noise currents from flowing in the output lines. There are several ways to do this. If it is a DC device, then either a diode or a M.O.V. (Metal Oxide Varistor) can be placed across the device to suppress it. The greater the current load of the device, the higher wattage diode required. If it is an AC load, then a M.O.V. or capacitor and resistor in series can be used. It can be seen that the output lines can be noise sources and as such should be kept away from the instrument's own input lines, as well as the input lines of other instruments.

In addition to the foregoing considerations, care should be taken when connecting input and output returns to the instrument's common. When separate input and output commons are provided, they should not be mixed. When an output device return is connected to an input common (See Fig. 4), the output current will flow in the input common line. This will cause a noise voltage to be present, which can affect the operation of the instrument.

In summary, it is much easier to eliminate problems when building up a system than after it is installed.

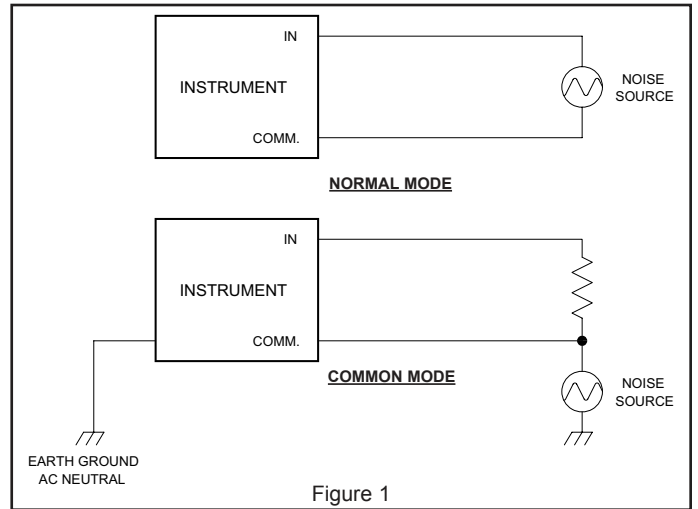

Figure 1

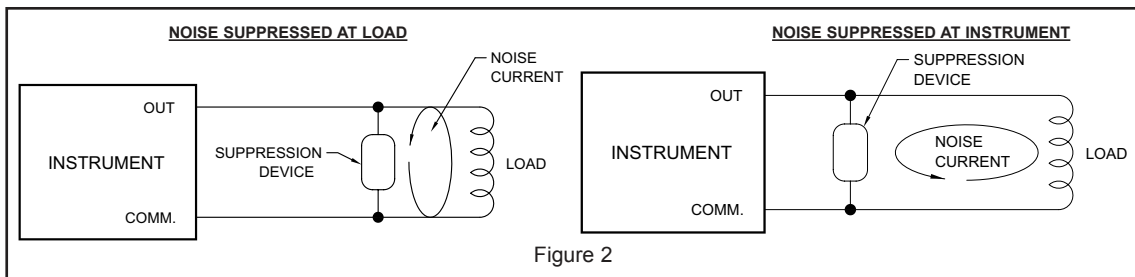

Figure 2

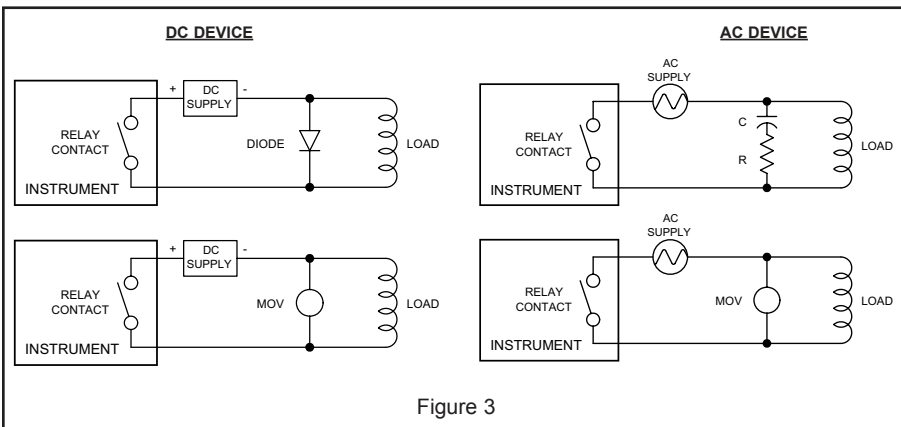

Figure 3

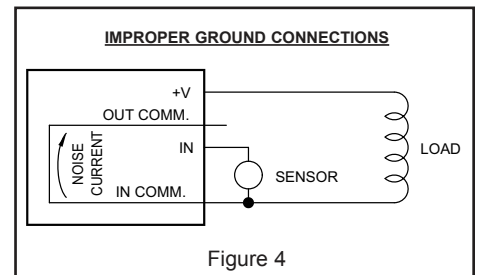

Figure 4