

# SN54LS673, SN54LS674, SN74LS673, SN74LS674 16-BIT SHIFT REGISTERS

SDLS195 – MARCH 1985 – REVISED MARCH 1988

## 'LS673

- 16-Bit Serial-In, Serial-Out Shift Register with 16-Bit Parallel-Out Storage Register
- Performs Serial-to-Parallel Conversion

## 'LS674

- 16-Bit Parallel-In, Serial-Out Shift Register
- Performs Parallel-to-Serial Conversion

## description

### SN54LS673, SN74LS673

The 'LS673 is a 16-bit shift register and a 16-bit storage register in a single 24-pin package. A three-state input/output (SER/Q15) port to the shift register allows serial entry and/or reading of data. The storage register is connected in a parallel data loop with the shift register and may be asynchronously cleared by taking the store-clear input low. The storage register may be parallel loaded with shift-register data to provide shift-register status via the parallel outputs. The shift register can be parallel loaded with the storage-register data upon command.

A high logic level at the chip-level ( $\overline{CS}$ ) input disables both the shift-register clock and the storage register clock and places SER/Q15 in the high-impedance state. The store-clear function is not disabled by the chip select.

Caution must be exercised to prevent false clocking of either the shift register or the storage register via the chip-select input. The shift clock should be low during the low-to-high transition of chip select and the store clock should be low during the high-to-low transition of chip select.

### SN54LS674, SN74LS674

The 'LS674 is a 16-bit parallel-in, serial-out shift register. A three-state input/output (SER/Q15) port provides access for entering a serial data or reading the shift-register word in a recirculating loop.

The device has four basic modes of operation:

- 1) Hold (do nothing)
- 2) Write (serially via input/output)
- 3) Read (serially)
- 4) Load (parallel via data inputs)

Low-to-high-level changes at the chip select input should be made only when the clock input is low to prevent false clocking.

### SN54LS673 . . . J OR W PACKAGE SN74LS673 . . . DW OR N PACKAGE (TOP VIEW)

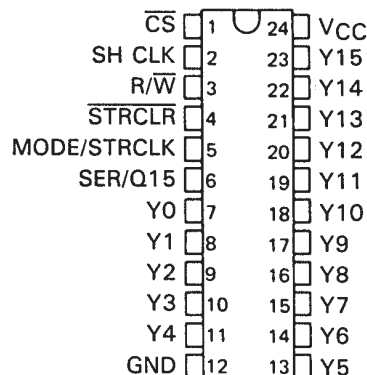

### SN54LS673 . . . FK PACKAGE (TOP VIEW)

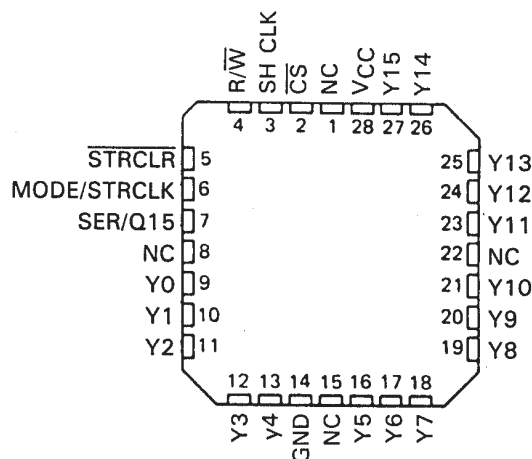

NC—No internal connection

# SN54LS673, SN54LS674, SN74LS673, SN74LS674 16-BIT SHIFT REGISTERS

SDLS195 – MARCH 1985 – REVISED MARCH 1988

SN54LS674 . . . J OR W PACKAGE  
SN74LS674 . . . DW OR N PACKAGE  
(TOP VIEW)

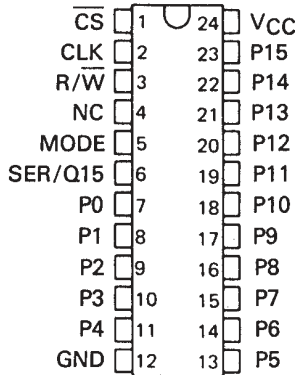

SN54LS674 . . . FK PACKAGE  
(TOP VIEW)

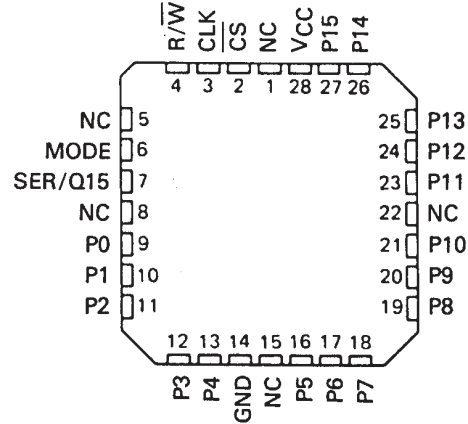

'LS673  
FUNCTION TABLE

INPUTS					SER/ Q15	SHIFT REGISTER FUNCTIONS				STORAGE REGISTER FUNCTIONS	
CS	R/W	SH CLK	STRCLR	MODE/ STRCLK		SHIFT	READ FROM SERIAL OUTPUT	WRITE INTO SERIAL INPUT	PARALLEL LOAD	CLEAR	LOAD
H	X	X	X	X	Z	NO	NO	NO	NO		NO
X	X	X	L	X						YES	
L	L	↓	X	X	Z	YES	NO	YES	NO		
L	H	X	X	X	Q15		YES	NO			NO
L	H	↓	X	L	Q14n	YES	YES	NO	NO		NO
L	H	↓	L	H	L	NO	YES		YES	YES	NO
L	H	↓	H	H	Y15n	NO	YES		YES	NO	NO
L	L	X	H	↑	Z		NO		NO	NO	YES

'LS674 FUNCTION TABLE

INPUTS				SER/ Q15	OPERATION
CS	R/W	MODE	CLK		
H	X	X	X	Z	Do nothing
L	L	X	↓	Z	Shift and write (serial load)
L	H	L	↓	Q14n	Shift and read
L	H	H	↓	P15	Parallel load

H = high level (steady state)  
L = low level (steady state)  
↑ = transition from low to high level  
↓ = transition from high to low level  
X = irrelevant (any input including transitions)  
Z = high impedance, input mode  
Q14n = content of 14th bit of the shift register before the most recent ↓ transition of the clock.  
Q15 = present content of 15th bit of the shift register  
Y15n = content of the 15th bit of the storage register before the most recent ↓ transition of the clock.  
P15 = level of input P15

# SN54LS673, SN54LS674, SN74LS673, SN74LS674 16-BIT SHIFT REGISTERS

SDLS195 – MARCH 1985 – REVISED MARCH 1988

logic symbols†

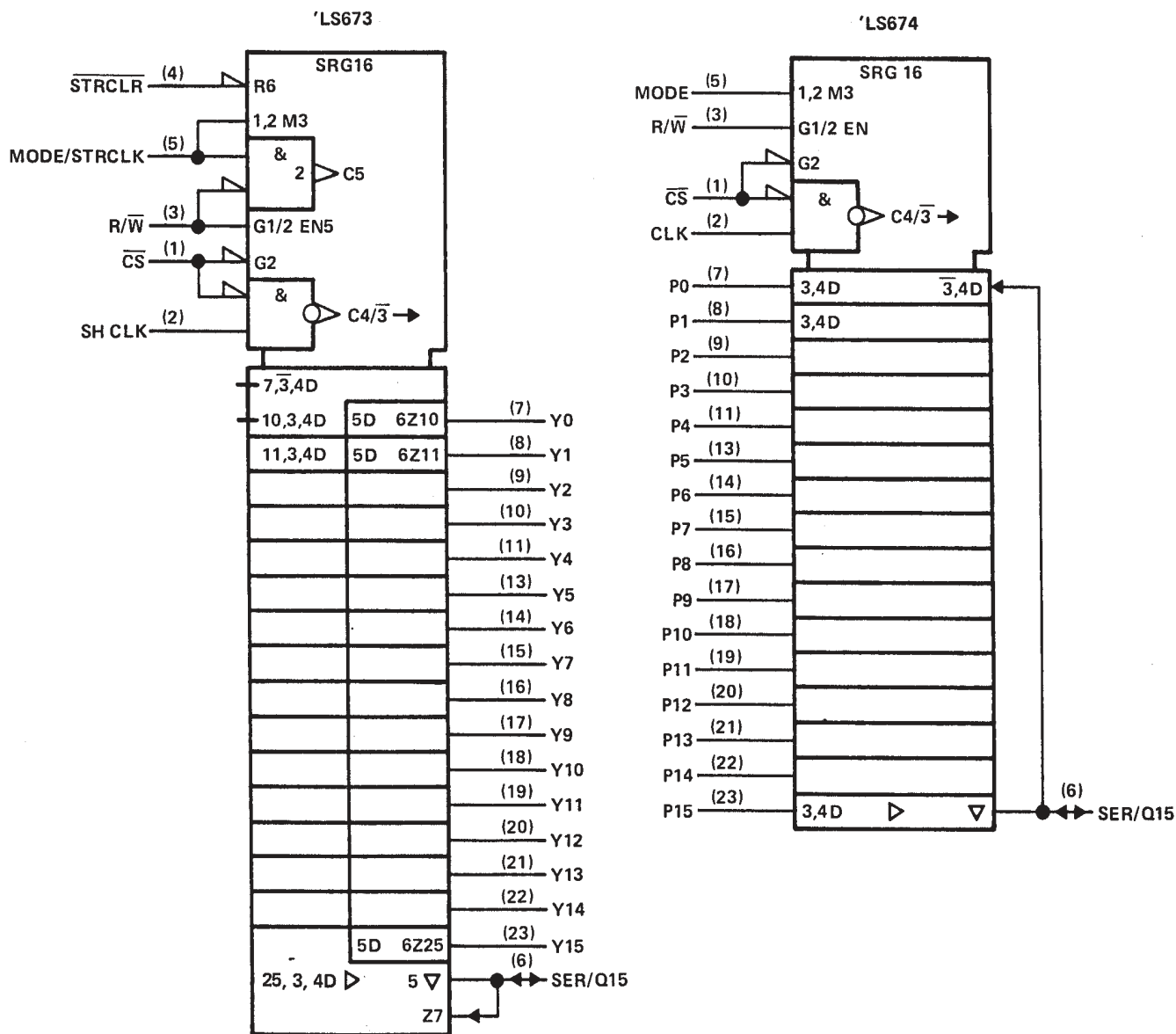

†These symbols are in accordance with ANSI/IEEE Std. 91-1984 and IEC Publication 617-12. Pin numbers shown are for DW, J, N, and W packages.

# SN54LS673, SN54LS674, SN74LS673, SN74LS674 16-BIT SHIFT REGISTERS

SDLS195 – MARCH 1985 – REVISED MARCH 1988

## functional block diagrams

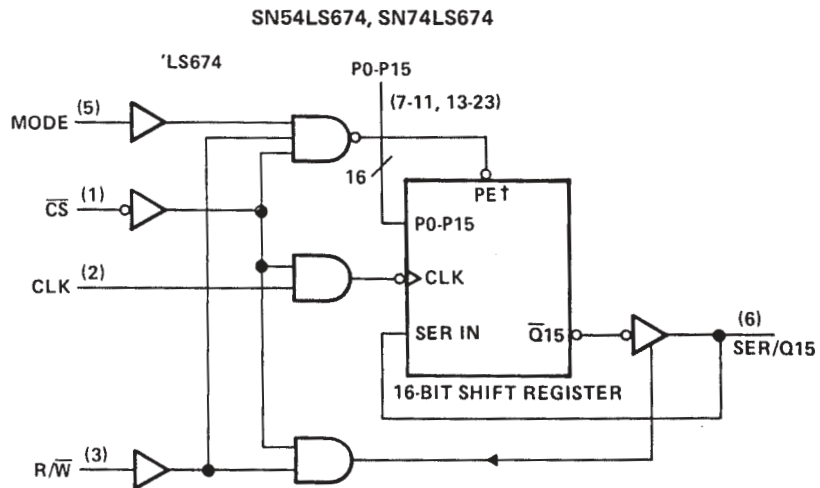
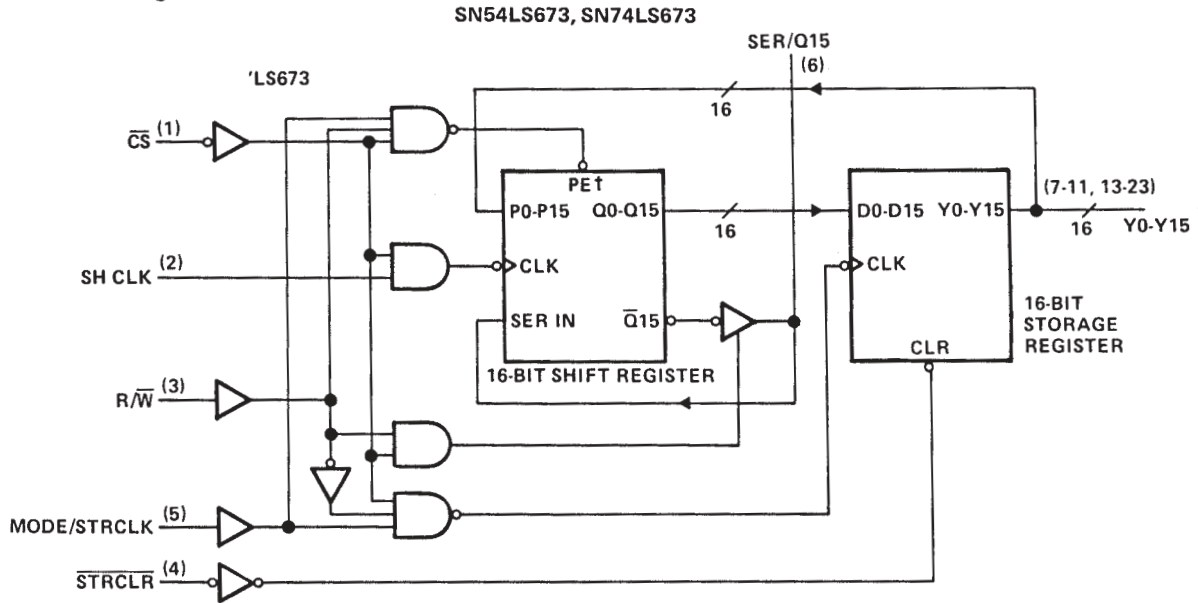

†When PE is active, data is synchronously parallel loaded into the shift registers from the 16 P inputs and no shifting takes place. Pin numbers shown are for DW, J, N, and W packages.

# SN54LS673, SN54LS674, SN74LS673, SN74LS674 16-BIT SHIFT REGISTERS

SDLS195 – MARCH 1985 – REVISED MARCH 1988

## schematics of inputs and outputs

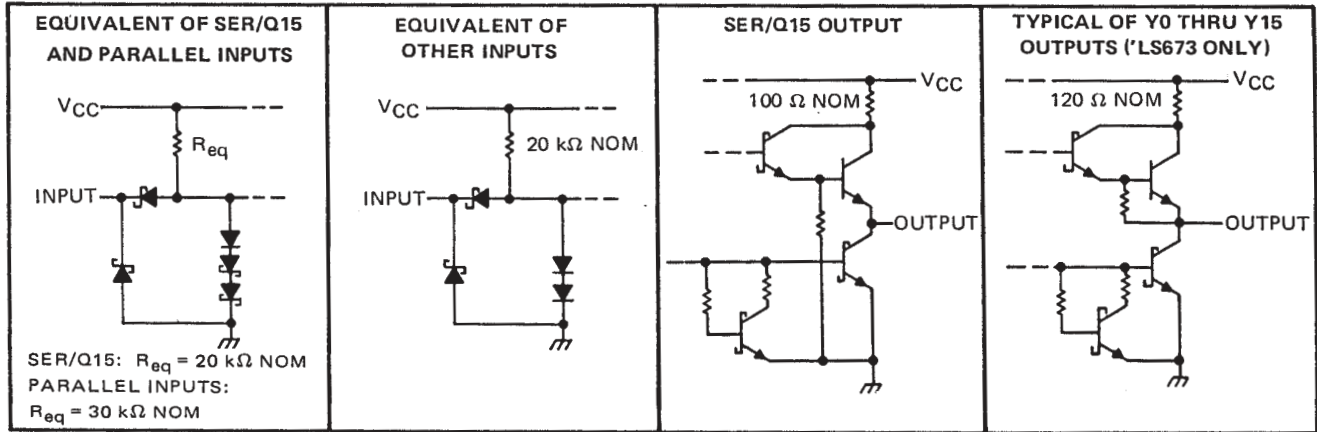

## absolute maximum ratings over operating free-air temperature range (unless otherwise noted)

Supply voltage, $V_{CC}$ (see Note 1)	7 V
Input voltage: SER/Q15	5.5 V
All others	7 V
Off-state output voltage	5.5 V
Operating free-air temperature range: SN54LS673, SN54LS674	-55°C to 125°C
SN74LS673, SN74LS674	0°C to 70°C
Storage temperature range	-65°C to 150°C

NOTE 1. Voltage values are with respect to network ground terminal.

## recommended operating conditions

		SN54LS'			SN74LS'			UNIT
		MIN	NOM	MAX	MIN	NOM	MAX	
$V_{CC}$	Supply voltage	4.5	5	5.5	4.75	5	5.25	V
$I_{OH}$	High-level output current	SER/Q15		-1	Y0 thru Y15		-2.6	mA
		Y0 thru Y15		-0.4	Y0 thru Y15		-0.4	
$I_{OL}$	Low-level output current	SER/Q15		12	Y0 thru Y15		24	mA
		Y0 thru Y15		4	Y0 thru Y15		8	
$f_{clock}$	Clock frequency	0		20	0		20	MHz
$t_{w(clock)}$	Width of clock input pulse	20			20			ns
$t_{w(clear)}$	Width of clear input pulse	20			20			ns
$t_{su}$	Setup time	SER/Q15		20	Y0 thru Y15		20	ns
		P0 thru P15		20	Y0 thru Y15		20	
		Mode		35	Y0 thru Y15		35	
		$R/\overline{W}, \overline{CS}$		35	Y0 thru Y15		35	
		SH CLK ↓ to Mode/STR CLK ↑ See Note 2		25	Y0 thru Y15		25	
$t_h$	Hold time	SER/Q15		0	Y0 thru Y15		0	ns
		P0 thru P15	'LS673	0	Y0 thru Y15		0	
			'LS674	5.0	Y0 thru Y15		5.0	
Mode		0	Y0 thru Y15		0			
$T_A$	Operating free-air temperature	-55		125	0		70	°C

NOTE 2: This setup time ensures the storage register will see stable data from the shift register.



# SN54LS673, SN54LS674, SN74LS673, SN74LS674 16-BIT SHIFT REGISTERS

SDLS195 – MARCH 1985 – REVISED MARCH 1988

electrical characteristics over recommended operating free-air temperature range (unless otherwise noted)

PARAMETER		TEST CONDITIONS†	SN54LS'		SN74LS'		UNIT
			MIN	TYP‡	MAX	MIN	
V <sub>IH</sub>	High-level input voltage		2		2		V
V <sub>IL</sub>	Low-level input voltage			0.7		0.8	V
V <sub>IK</sub>	Input clamp voltage	V <sub>CC</sub> = MIN, I <sub>I</sub> = -18 mA		-1.5		-1.5	V
V <sub>OH</sub>	High-level output voltage	SER/Q15	V <sub>CC</sub> = MIN, V <sub>IH</sub> = 2 V,		2.4	3.1	V
		Y0 thru Y15¶	V <sub>IL</sub> = V <sub>ILmax</sub> , I <sub>OH</sub> = MAX		2.5	3.4	
V <sub>OL</sub>	Low-level output voltage	SER/Q15	V <sub>CC</sub> = MIN, V <sub>IH</sub> = 2 V,	I <sub>OL</sub> = 12 mA	0.25	0.4	V
				I <sub>OL</sub> = 24 mA		0.35	
		Y0 thru Y15¶	V <sub>IL</sub> = V <sub>ILmax</sub>	I <sub>OL</sub> = 4 mA	0.25	0.4	
				I <sub>OL</sub> = 8 mA		0.35	
I <sub>OZH</sub>	Off-state output current, high-level voltage applied	SER/Q15	V <sub>CC</sub> = MAX, V <sub>IH</sub> = 2 V, V <sub>IL</sub> = V <sub>ILmax</sub> , V <sub>O</sub> = 2.7 V	40		40	μA
I <sub>OZL</sub>	Off-state output current, low-level voltage applied	SER/Q15	V <sub>CC</sub> = MAX, V <sub>IH</sub> = 2 V, V <sub>IL</sub> = V <sub>ILmax</sub> , V <sub>O</sub> = 0.4 V	-0.4		-0.4	mA
I <sub>I</sub>	Input current at maximum input voltage	SER/Q15	V <sub>CC</sub> = MAX	V <sub>I</sub> = 5.5 V		0.1	mA
		Others		V <sub>I</sub> = 7 V		0.1	
I <sub>IH</sub>	High-level input current	SER/Q15	V <sub>CC</sub> = MAX, V <sub>I</sub> = 2.7 V			40	μA
		Others				20	
I <sub>IL</sub>	Low-level input current		V <sub>CC</sub> = MAX, V <sub>I</sub> = 0.4 V			-0.4	mA
I <sub>OS</sub>	Short-circuit output current§	SER/Q15	V <sub>CC</sub> = MAX		-30	-130	mA
		Y0 thru Y15¶			-20	-100	
I <sub>CC</sub>	Supply current	'LS673	V <sub>CC</sub> = MAX		50	80	mA
		'LS674			25	40	

† For conditions shown as MIN or MAX use the appropriate value specified under recommended operating conditions.

‡ All typical values are at V<sub>CC</sub> = 5 V, T<sub>A</sub> = 25°C.

§ Not more than one output should be shorted at a time, and duration of the short circuit should not exceed one second.

¶ 'LS673 only.

switching characteristics, V<sub>CC</sub> = 5 V, T<sub>A</sub> = 25°C, see note 2

PARAMETER	'LS673		'LS674		TEST CONDITIONS	MIN	TYP	MAX	UNIT
	FROM	TO	FROM	TO					
f <sub>max</sub>	SH CLK	SER/Q15	CLK	SER/Q15	R <sub>L</sub> = 667 Ω, C <sub>L</sub> = 45 pF	20	28		MHz
t <sub>PHL</sub>	STRCLR	Y0 thru Y15			R <sub>L</sub> = 2 kΩ, C <sub>L</sub> = 15 pF		25	40	ns
t <sub>PLH</sub>	MODE/ STRCLK	Y0 thru Y15					28	45	
t <sub>PHL</sub>							30	45	
t <sub>PLH</sub>	SH CLK	SER/Q15	CLK	SER/Q15	R <sub>L</sub> = 667 Ω, C <sub>L</sub> = 45 pF		21	33	ns
t <sub>PHL</sub>							26	40	
t <sub>PZH</sub>	CS, R/W	SER/Q15	CS, R/W	SER/Q15	R <sub>L</sub> = 667 Ω, C <sub>L</sub> = 45 pF		30	45	ns
t <sub>PZL</sub>							30	45	
t <sub>PHZ</sub>	CS, R/W	SER/Q15	CS, R/W	SER/Q15	R <sub>L</sub> = 667 Ω, C <sub>L</sub> = 5 pF		25	40	ns
t <sub>PLZ</sub>							25	40	

NOTE 2: Load circuits and voltage waveforms are shown in Section 1.



**PACKAGING INFORMATION**

Orderable Device	Status (1)	Package Type	Package Drawing	Pins	Package Qty	Eco Plan (2)	Lead finish/ Ball material (6)	MSL Peak Temp (3)	Op Temp (°C)	Device Marking (4/5)	Samples
5962-88602013A	ACTIVE	LCCC	FK	28	1	Non-RoHS & Green	SNPB	N / A for Pkg Type	-55 to 125	5962-88602013A SNJ54LS 673FK	<a href="#">Samples</a>
5962-8860201JA	ACTIVE	CDIP	J	24	1	Non-RoHS & Non-Green	Call TI	N / A for Pkg Type	-55 to 125	5962-8860201JA SNJ54LS673J	<a href="#">Samples</a>
5962-8860201JA	ACTIVE	CDIP	J	24	1	Non-RoHS & Non-Green	Call TI	N / A for Pkg Type	-55 to 125	5962-8860201JA SNJ54LS673J	<a href="#">Samples</a>
5962-8860201LA	ACTIVE	CDIP	JT	24	1	Non-RoHS & Green	SNPB	N / A for Pkg Type	-55 to 125	5962-8860201LA SNJ54LS673JT	<a href="#">Samples</a>
5962-8860201LA	ACTIVE	CDIP	JT	24	1	Non-RoHS & Green	SNPB	N / A for Pkg Type	-55 to 125	5962-8860201LA SNJ54LS673JT	<a href="#">Samples</a>
5962-88607013A	ACTIVE	LCCC	FK	28	1	Non-RoHS & Green	SNPB	N / A for Pkg Type	-55 to 125	5962-88607013A SNJ54LS 674FK	<a href="#">Samples</a>
5962-88607013A	ACTIVE	LCCC	FK	28	1	Non-RoHS & Green	SNPB	N / A for Pkg Type	-55 to 125	5962-88607013A SNJ54LS 674FK	<a href="#">Samples</a>
5962-8860701JA	ACTIVE	CDIP	J	24	1	Non-RoHS & Non-Green	Call TI	N / A for Pkg Type	-55 to 125	5962-8860701JA SNJ54LS674J	<a href="#">Samples</a>
5962-8860701JA	ACTIVE	CDIP	J	24	1	Non-RoHS & Non-Green	Call TI	N / A for Pkg Type	-55 to 125	5962-8860701JA SNJ54LS674J	<a href="#">Samples</a>
SN54LS673J	ACTIVE	CDIP	J	24	1	Non-RoHS & Non-Green	Call TI	N / A for Pkg Type	-55 to 125	SN54LS673J	<a href="#">Samples</a>
SN54LS673J	ACTIVE	CDIP	J	24	1	Non-RoHS & Non-Green	Call TI	N / A for Pkg Type	-55 to 125	SN54LS673J	<a href="#">Samples</a>
SN54LS674J	ACTIVE	CDIP	J	24	1	Non-RoHS & Non-Green	Call TI	N / A for Pkg Type	-55 to 125	SN54LS674J	<a href="#">Samples</a>
SN54LS674J	ACTIVE	CDIP	J	24	1	Non-RoHS & Non-Green	Call TI	N / A for Pkg Type	-55 to 125	SN54LS674J	<a href="#">Samples</a>
SN74LS673DW	ACTIVE	SOIC	DW	24	25	RoHS & Green	NIPDAU	Level-1-260C-UNLIM	0 to 70	LS673	<a href="#">Samples</a>

Orderable Device	Status (1)	Package Type	Package Drawing	Pins	Package Qty	Eco Plan (2)	Lead finish/ Ball material (6)	MSL Peak Temp (3)	Op Temp (°C)	Device Marking (4/5)	Samples
SN74LS673DW	ACTIVE	SOIC	DW	24	25	RoHS & Green	NIPDAU	Level-1-260C-UNLIM	0 to 70	LS673	<a href="#">Samples</a>
SN74LS674DW	ACTIVE	SOIC	DW	24	25	RoHS & Green	NIPDAU	Level-1-260C-UNLIM	0 to 70	LS674	<a href="#">Samples</a>
SN74LS674DW	ACTIVE	SOIC	DW	24	25	RoHS & Green	NIPDAU	Level-1-260C-UNLIM	0 to 70	LS674	<a href="#">Samples</a>
SNJ54LS673FK	ACTIVE	LCCC	FK	28	1	Non-RoHS & Green	SNPB	N / A for Pkg Type	-55 to 125	5962-88602013A SNJ54LS673FK	<a href="#">Samples</a>
SNJ54LS673FK	ACTIVE	LCCC	FK	28	1	Non-RoHS & Green	SNPB	N / A for Pkg Type	-55 to 125	5962-88602013A SNJ54LS673FK	<a href="#">Samples</a>
SNJ54LS673J	ACTIVE	CDIP	J	24	1	Non-RoHS & Non-Green	Call TI	N / A for Pkg Type	-55 to 125	5962-8860201JA SNJ54LS673J	<a href="#">Samples</a>
SNJ54LS673J	ACTIVE	CDIP	J	24	1	Non-RoHS & Non-Green	Call TI	N / A for Pkg Type	-55 to 125	5962-8860201JA SNJ54LS673J	<a href="#">Samples</a>
SNJ54LS673JT	ACTIVE	CDIP	JT	24	1	Non-RoHS & Green	SNPB	N / A for Pkg Type	-55 to 125	5962-8860201LA SNJ54LS673JT	<a href="#">Samples</a>
SNJ54LS673JT	ACTIVE	CDIP	JT	24	1	Non-RoHS & Green	SNPB	N / A for Pkg Type	-55 to 125	5962-8860201LA SNJ54LS673JT	<a href="#">Samples</a>
SNJ54LS674FK	ACTIVE	LCCC	FK	28	1	Non-RoHS & Green	SNPB	N / A for Pkg Type	-55 to 125	5962-88607013A SNJ54LS674FK	<a href="#">Samples</a>
SNJ54LS674FK	ACTIVE	LCCC	FK	28	1	Non-RoHS & Green	SNPB	N / A for Pkg Type	-55 to 125	5962-88607013A SNJ54LS674FK	<a href="#">Samples</a>
SNJ54LS674J	ACTIVE	CDIP	J	24	1	Non-RoHS & Non-Green	Call TI	N / A for Pkg Type	-55 to 125	5962-8860701JA SNJ54LS674J	<a href="#">Samples</a>
SNJ54LS674J	ACTIVE	CDIP	J	24	1	Non-RoHS & Non-Green	Call TI	N / A for Pkg Type	-55 to 125	5962-8860701JA SNJ54LS674J	<a href="#">Samples</a>

(1) The marketing status values are defined as follows:

**ACTIVE:** Product device recommended for new designs.

**LIFEBUY:** TI has announced that the device will be discontinued, and a lifetime-buy period is in effect.



**NRND:** Not recommended for new designs. Device is in production to support existing customers, but TI does not recommend using this part in a new design.

**PREVIEW:** Device has been announced but is not in production. Samples may or may not be available.

**OBSOLETE:** TI has discontinued the production of the device.

<sup>(2)</sup> **RoHS:** TI defines "RoHS" to mean semiconductor products that are compliant with the current EU RoHS requirements for all 10 RoHS substances, including the requirement that RoHS substance do not exceed 0.1% by weight in homogeneous materials. Where designed to be soldered at high temperatures, "RoHS" products are suitable for use in specified lead-free processes. TI may reference these types of products as "Pb-Free".

**RoHS Exempt:** TI defines "RoHS Exempt" to mean products that contain lead but are compliant with EU RoHS pursuant to a specific EU RoHS exemption.

**Green:** TI defines "Green" to mean the content of Chlorine (Cl) and Bromine (Br) based flame retardants meet JS709B low halogen requirements of  $\leq 1000$ ppm threshold. Antimony trioxide based flame retardants must also meet the  $\leq 1000$ ppm threshold requirement.

<sup>(3)</sup> MSL, Peak Temp. - The Moisture Sensitivity Level rating according to the JEDEC industry standard classifications, and peak solder temperature.

<sup>(4)</sup> There may be additional marking, which relates to the logo, the lot trace code information, or the environmental category on the device.

<sup>(5)</sup> Multiple Device Markings will be inside parentheses. Only one Device Marking contained in parentheses and separated by a "~" will appear on a device. If a line is indented then it is a continuation of the previous line and the two combined represent the entire Device Marking for that device.

<sup>(6)</sup> Lead finish/Ball material - Orderable Devices may have multiple material finish options. Finish options are separated by a vertical ruled line. Lead finish/Ball material values may wrap to two lines if the finish value exceeds the maximum column width.

**Important Information and Disclaimer:** The information provided on this page represents TI's knowledge and belief as of the date that it is provided. TI bases its knowledge and belief on information provided by third parties, and makes no representation or warranty as to the accuracy of such information. Efforts are underway to better integrate information from third parties. TI has taken and continues to take reasonable steps to provide representative and accurate information but may not have conducted destructive testing or chemical analysis on incoming materials and chemicals. TI and TI suppliers consider certain information to be proprietary, and thus CAS numbers and other limited information may not be available for release.

In no event shall TI's liability arising out of such information exceed the total purchase price of the TI part(s) at issue in this document sold by TI to Customer on an annual basis.

**OTHER QUALIFIED VERSIONS OF SN54LS673, SN54LS674, SN74LS673, SN74LS674 :**

● Catalog : [SN74LS673](#), [SN74LS674](#)

● Military : [SN54LS673](#), [SN54LS674](#)

NOTE: Qualified Version Definitions:

● Catalog - TI's standard catalog product

- Military - QML certified for Military and Defense Applications

**TUBE**

\*All dimensions are nominal

Device	Package Name	Package Type	Pins	SPQ	L (mm)	W (mm)	T (μm)	B (mm)
SN74LS673DW	DW	SOIC	24	25	506.98	12.7	4826	6.6
SN74LS674DW	DW	SOIC	24	25	506.98	12.7	4826	6.6

DW (R-PDSO-G24)

PLASTIC SMALL OUTLINE

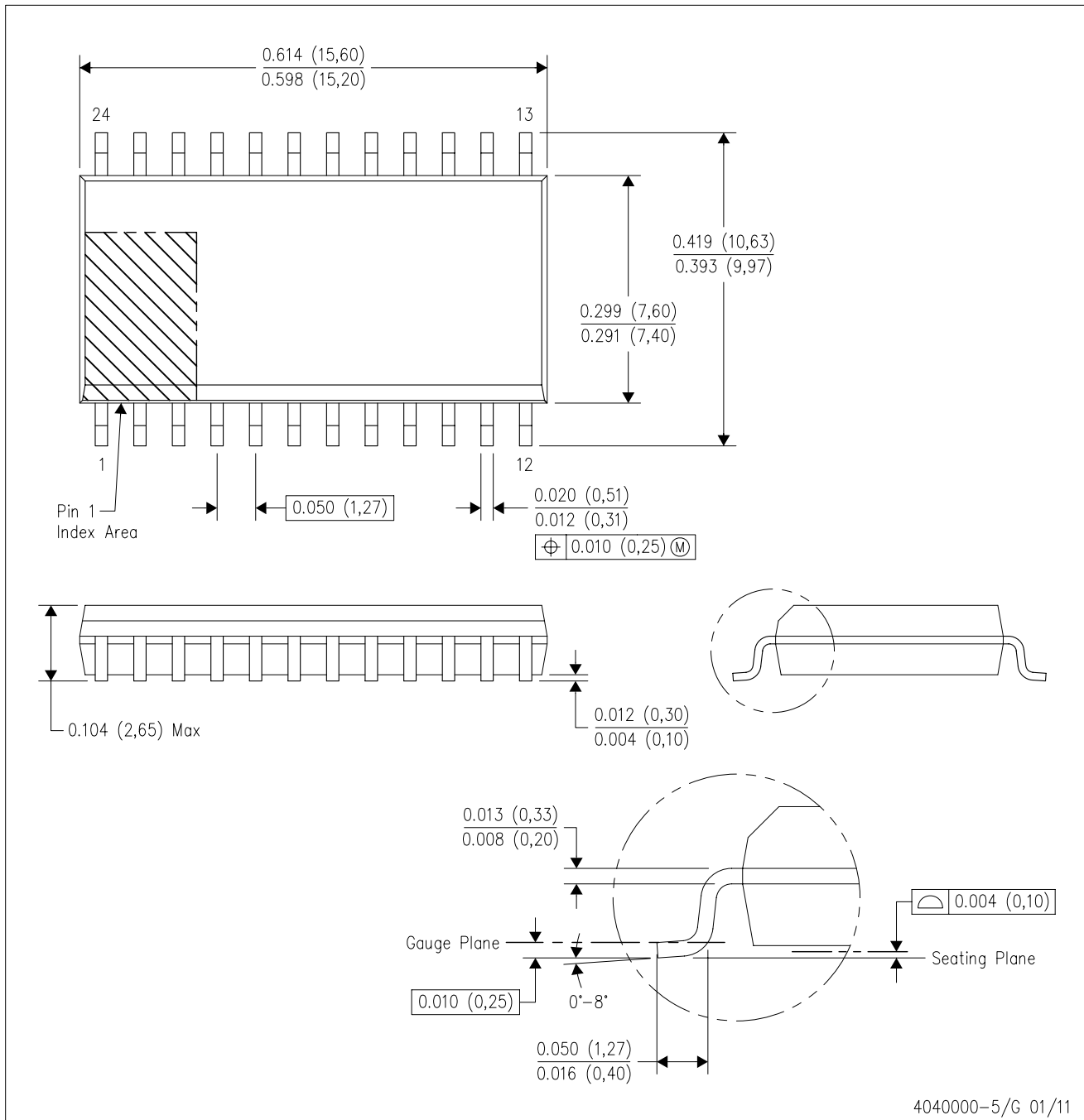

- NOTES:
- A. All linear dimensions are in inches (millimeters). Dimensioning and tolerancing per ASME Y14.5M-1994.
  - B. This drawing is subject to change without notice.
  - C. Body dimensions do not include mold flash or protrusion not to exceed 0.006 (0,15).
  - D. Falls within JEDEC MS-013 variation AD.

J (R-GDIP-T\*\*)

CERAMIC DUAL-IN-LINE PACKAGE

24 PINS SHOWN

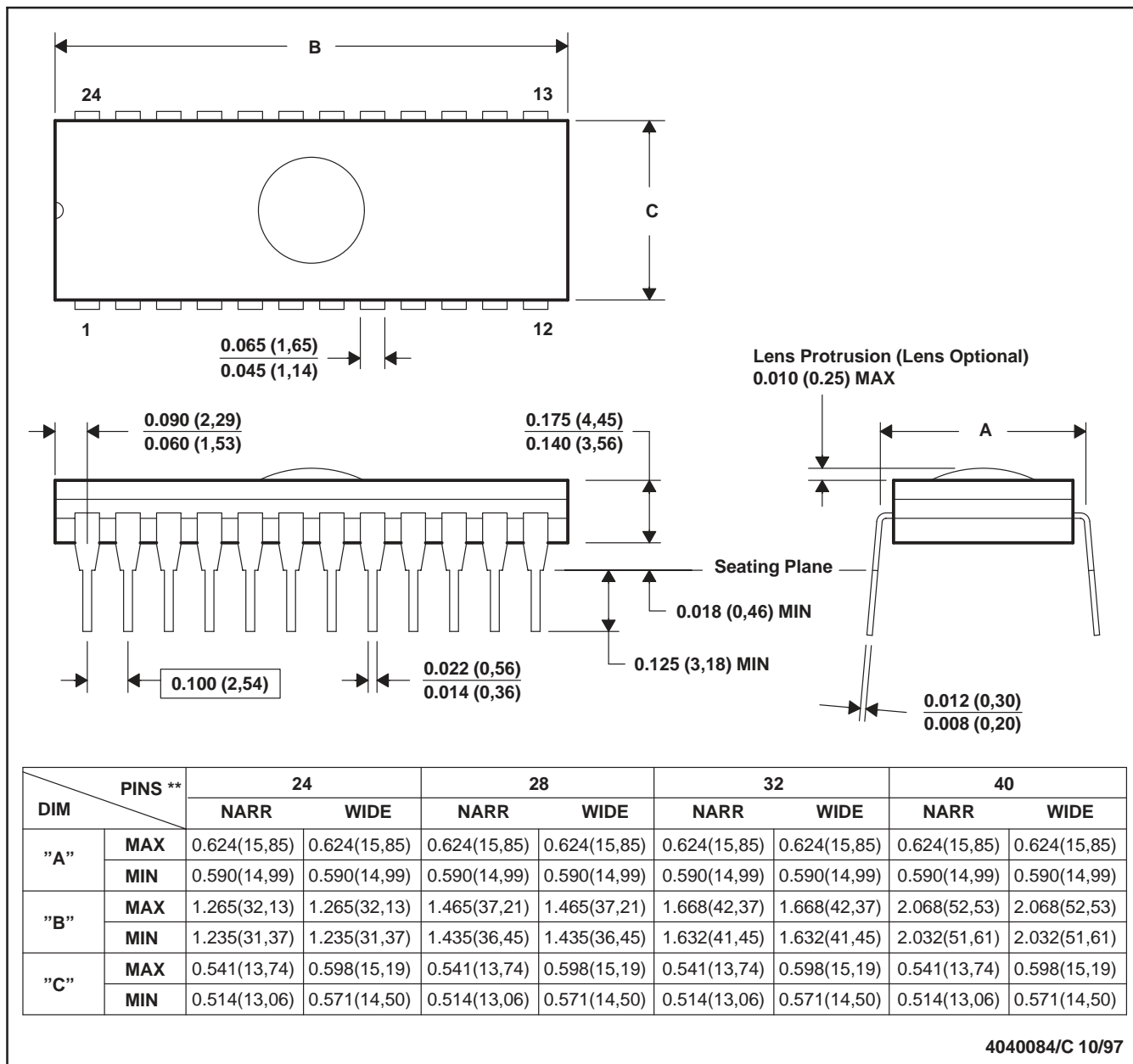

- NOTES: A. All linear dimensions are in inches (millimeters).  
 B. This drawing is subject to change without notice.  
 C. Window (lens) added to this group of packages (24-, 28-, 32-, 40-pin).  
 D. This package can be hermetically sealed with a ceramic lid using glass frit.  
 E. Index point is provided on cap for terminal identification.

JT (R-GDIP-T\*\*)

CERAMIC DUAL-IN-LINE

24 LEADS SHOWN

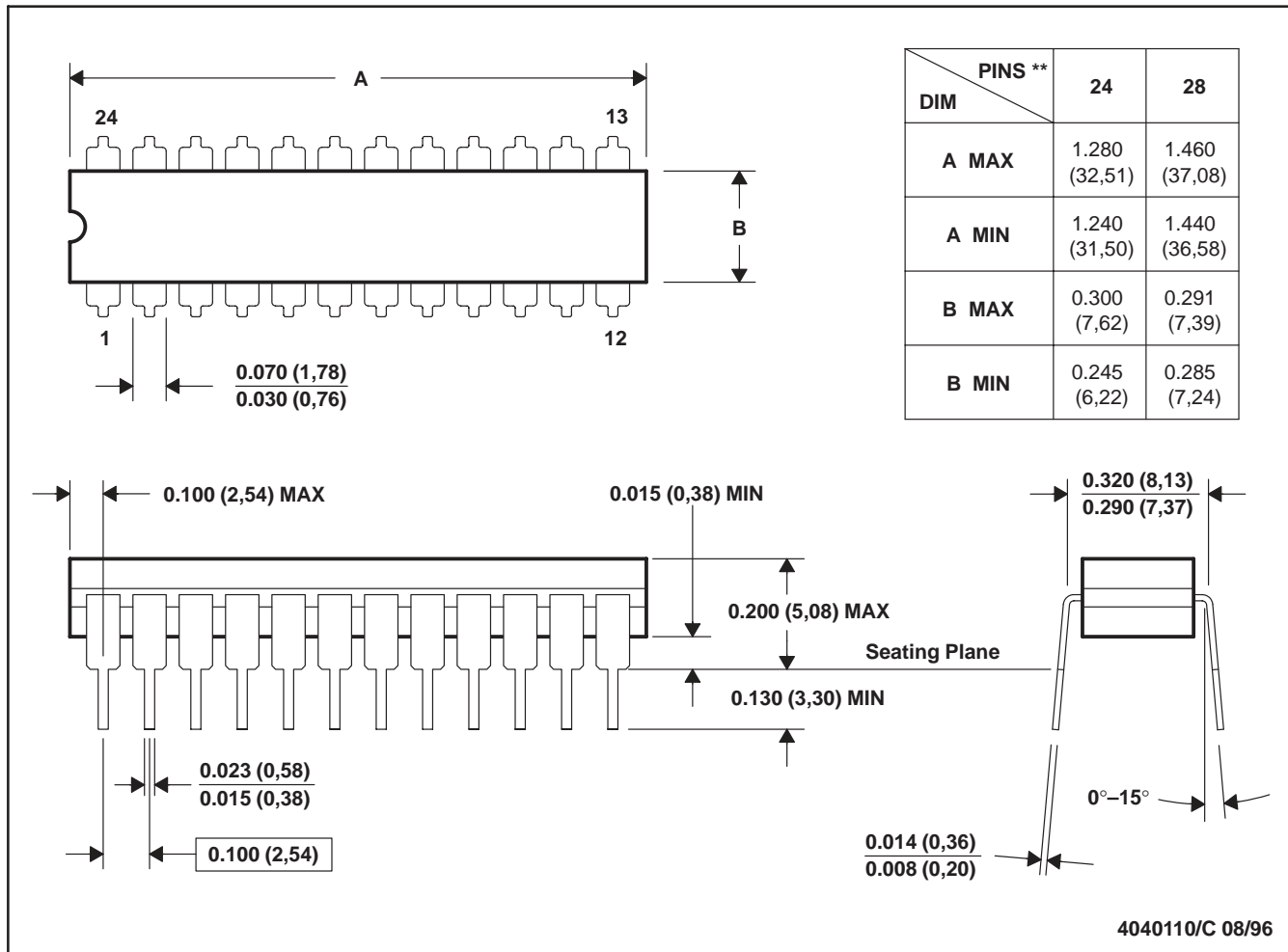

- NOTES: A. All linear dimensions are in inches (millimeters).  
 B. This drawing is subject to change without notice.  
 C. This package can be hermetically sealed with a ceramic lid using glass frit.  
 D. Index point is provided on cap for terminal identification.  
 E. Falls within MIL STD 1835 GDIP3-T24, GDIP4-T28, and JEDEC MO-058 AA, MO-058 AB

FK (S-CQCC-N\*\*)

LEADLESS CERAMIC CHIP CARRIER

28 TERMINAL SHOWN



NO. OF TERMINALS **	A		B	
	MIN	MAX	MIN	MAX
20	0.342 (8,69)	0.358 (9,09)	0.307 (7,80)	0.358 (9,09)
28	0.442 (11,23)	0.458 (11,63)	0.406 (10,31)	0.458 (11,63)
44	0.640 (16,26)	0.660 (16,76)	0.495 (12,58)	0.560 (14,22)
52	0.740 (18,78)	0.761 (19,32)	0.495 (12,58)	0.560 (14,22)
68	0.938 (23,83)	0.962 (24,43)	0.850 (21,6)	0.858 (21,8)
84	1.141 (28,99)	1.165 (29,59)	1.047 (26,6)	1.063 (27,0)



4040140/D 01/11

- NOTES:
- All linear dimensions are in inches (millimeters).
  - This drawing is subject to change without notice.
  - This package can be hermetically sealed with a metal lid.
  - Falls within JEDEC MS-004

## IMPORTANT NOTICE AND DISCLAIMER

TI PROVIDES TECHNICAL AND RELIABILITY DATA (INCLUDING DATA SHEETS), DESIGN RESOURCES (INCLUDING REFERENCE DESIGNS), APPLICATION OR OTHER DESIGN ADVICE, WEB TOOLS, SAFETY INFORMATION, AND OTHER RESOURCES "AS IS" AND WITH ALL FAULTS, AND DISCLAIMS ALL WARRANTIES, EXPRESS AND IMPLIED, INCLUDING WITHOUT LIMITATION ANY IMPLIED WARRANTIES OF MERCHANTABILITY, FITNESS FOR A PARTICULAR PURPOSE OR NON-INFRINGEMENT OF THIRD PARTY INTELLECTUAL PROPERTY RIGHTS.

These resources are intended for skilled developers designing with TI products. You are solely responsible for (1) selecting the appropriate TI products for your application, (2) designing, validating and testing your application, and (3) ensuring your application meets applicable standards, and any other safety, security, regulatory or other requirements.

These resources are subject to change without notice. TI grants you permission to use these resources only for development of an application that uses the TI products described in the resource. Other reproduction and display of these resources is prohibited. No license is granted to any other TI intellectual property right or to any third party intellectual property right. TI disclaims responsibility for, and you will fully indemnify TI and its representatives against, any claims, damages, costs, losses, and liabilities arising out of your use of these resources.

TI's products are provided subject to [TI's Terms of Sale](#) or other applicable terms available either on [ti.com](http://ti.com) or provided in conjunction with such TI products. TI's provision of these resources does not expand or otherwise alter TI's applicable warranties or warranty disclaimers for TI products.

TI objects to and rejects any additional or different terms you may have proposed.

Mailing Address: Texas Instruments, Post Office Box 655303, Dallas, Texas 75265  
Copyright © 2022, Texas Instruments Incorporated