

1. Configuration & Dimensions (in mm):

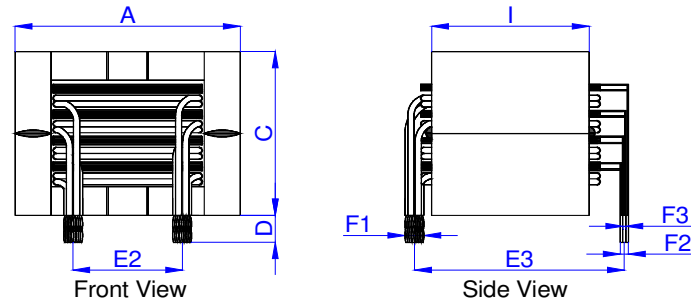

A	42.00	(Max.)	mm
B	40.00	(Max.)	mm
C	30.00	(Max.)	mm
D	6.00	± 1.00	mm
E1	8.50	± 0.50	mm
E2	18.50	± 0.50	mm
E3	36.75	± 0.75	mm
F1	2.95	(Max.)	mm
F2	2.00	± 0.50	mm
F3	1.00	± 0.50	mm
H	5.00	± 0.50	mm
I	28.00	± 0.50	mm

2.Schematic Diagram:

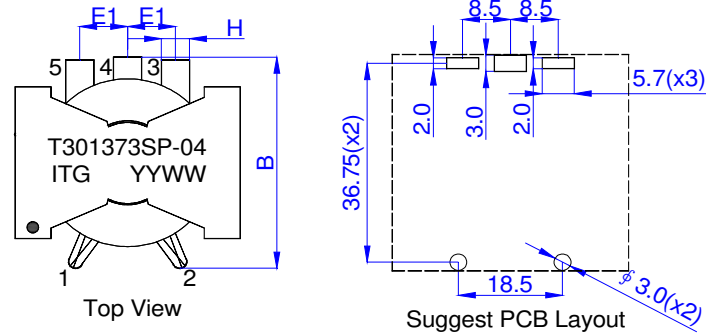
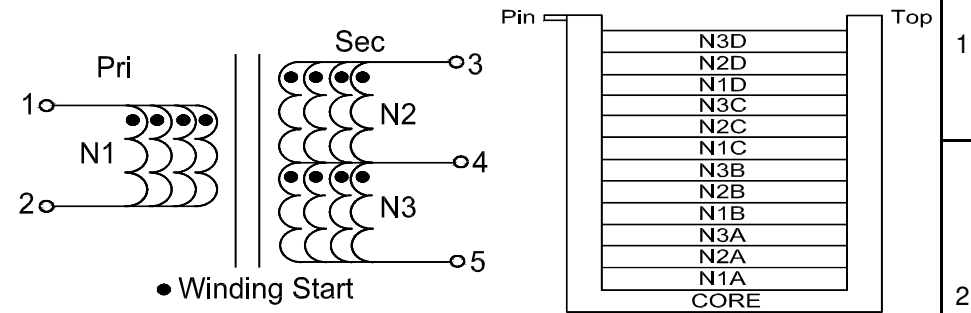

3. Electrical Characteristics (Ta=25°C):

- 1>Open Circuit Inductance (OCL):
L(PIN1-2): 75.0uH±10% @100KHz/0.25V (Ta=25°C).
- 2>Leakage Inductance:
Lk(PIN1-2): 3.0.uH Max. @100KHz/0.25V;Short other PIN.
- 3>DCR(PIN1-2): 18.0mΩ Max. (Ta=25°C).
DCR(PIN3-4): 1.8mΩ Max. (Ta=25°C).
DCR(PIN4-5): 1.8mΩ Max. (Ta=25°C).
- 4>Hi-Pot (Pri to Sec): AC3.0KV/5mA/2s./50/60Hz.
Hi-Pot (Pri to Core): AC1.5KV/5mA/2s./50/60Hz.
Hi-Pot (Sec to Core): AC0.5KV/5mA/2s./50/60Hz.
- 5>Turns ratio (Winding Pri : Sec1 : Sec2) = 15 : 2 : 2.

Notes:

- 1> Operating Ambient Temperature: -25°C to + 125°C.
- 2> RoHS Compliant Component.
- 3> N1A,N1B,N1C,N1D Parallel connected,N2A,N2B,N2C,N2D Parallel connected, N3A,N3B,N3C,N3D Parallel connected.

REVISION HISTORY

REV	DATE	DESCRIPTION	APPROVED
A.0	2022/3/28	NEW	Mary Yang

UNLESS OTHERWISE SPECIFIED
DIMENSIONS ARE IN mm.

TOLERANCES
1PL ± 0.50
2PL ± 0.30

Third Angle Projection

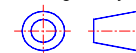

ITG Electronics, Inc.

T301373SP-04
PQ4030 Main Transformer;
75.0uH,18.0mΩDCR



DWG. NO.
T301373SP-04

REV.
A.0

SCALE: 1/1

SHEET 1 OF 1

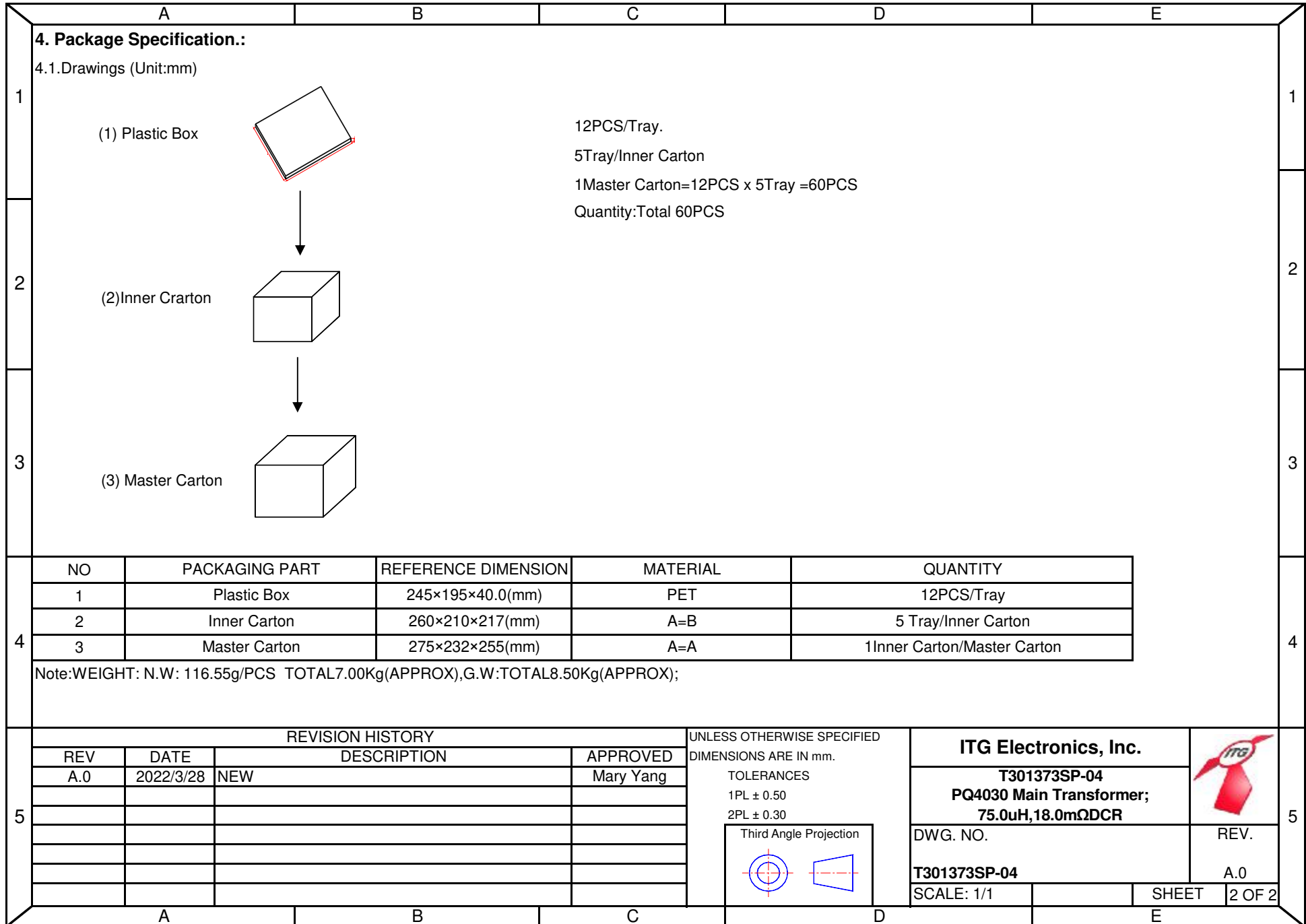

Due to continuous product improvement ,all specifications are subject to change without prior notice. Kindly contact an ITG field application engineer or a sales representative prior to purchase.