

6

5

4

3

2

1

P/N	LENGTH
79516-1021	1000 +/-50MM
79516-1023	3000 +/-100MM
79516-1025	5000 +/-150MM

EXT. "A"

EXT. "B"

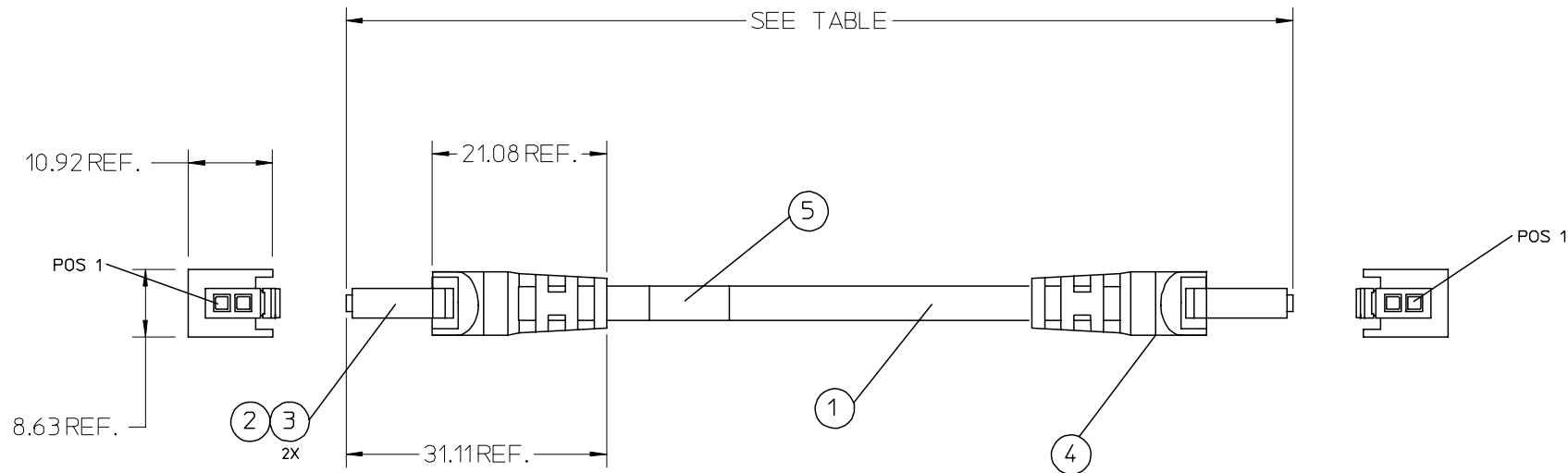

NOTES:

- PIN CONNECTION ACCORDING TO TABLE.
- LABEL CABLE WITH FOLLOWING INFORMATION:
P/N (SEE TABLE)
REV. (SEE REVISION TABLE)
M/D WW/YY
ASSEMBLED IN MEXICO

WIRING CHART

EXT. "A"		EXT. "B"
POS.	COLOR	POS.
1	BLACK	1
2	WHITE	2

ITEM	P/N	DESCRIPTION	QTY
5	0799212000	PLASTIC LABEL 0-TW10F	1 PC
4	0899920428	PVC 15% MF BLACK UL94V-2	A/R
3	0430300004	MicroFit 3.0 F Crp Term Chn Tin 26-30	4 PC
2	0430250200	MicroFit 3.0 DR Rcpt PnlMnt 2Ckt	2 PC
1	0799232214	CABLE 2 COND, 26AWG, JACKETED	A/R

RELEASED EC NO: MEX2006-0156 DRWN: AOROZCO 2006/03/31 CHKD: ACUEVAS 2006/03/31 APPR: ACUEVAS 2006/04/03	QUALITY SYMBOLS ▽=0 ▽=0	GENERAL TOLERANCES (UNLESS SPECIFIED)		DIMENSION STYLE MM ONLY		SCALE ---	DESIGN UNITS METRIC	THIRD ANGLE PROJECTION		
			mm	INCH	DRAWN BY AOROZCO	DATE 10/10/2003	TITLE MICRO-FIT OVERMOLDED ASSEMBLY 2 CKT 1, 3 & 5 MTS.			
		4 PLACES	±---	±---	CHECKED BY AOROZCO	DATE 10/10/2003				
		3 PLACES	±---	±---	APPROVED BY ACUEVAS	DATE 10/10/2003				
2 PLACES	±---	±---	ANGULAR ±---°		MATERIAL NO. VARIOS	DOCUMENT NO. SD-79516-001	SHEET NO. 1 OF 1			
1 PLACE	±---	±---	DRAFT WHERE APPLICABLE MUST REMAIN WITHIN DIMENSIONS		SIZE A	THIS DRAWING CONTAINS INFORMATION THAT IS PROPRIETARY TO MOLEX INCORPORATED AND SHOULD NOT BE USED WITHOUT WRITTEN PERMISSION				

5

4

3

2

1