



CUSTOMER: 研華股份有限公司

APPROVAL SHEET

APPROVED NO. : 90002-T0066

ISSUE DATE : December-23-2010

MODULE PART NO. : 78.A2GCF.AF10C

PCB PART NO. : 48.18225.091

IC Brand : Hynix

DESCRIPTION : DDR3 SO-CDIMM 10600-9 256x8 2GB HYN G

CUSTOMER APPROVAL :

Apacer Technology Inc.

Authorized by : Steven Wang

2GB DDR3 SDRAM 72bit SO-DIMM

Part Number	Bandwidth	Speed Grade	Max Frequency	CAS Latency	Density	Organization	Component Composition	Number of Rank
78.A2GCF.XX10C	10.6GB/sec	1333Mbps	666MHz	CL9	2GB	256Mx72	256Mx8 * 9	1

Specifications

- Support ECC error detection and correction
- On DIMM Thermal Sensor: YES
- Density: 2GB
- Organization – 256 word x 72 bits, 1 rank
- Mounting 9 pieces of 2G bits DDR3 SDRAM sealed FBGA
- Package: 204-pin socket type small outline dual in line memory module (SO-DIMM)
 - PCB height: 30.0mm
 - Lead pitch: 0.6mm (pin)
 - Lead-free (RoHS compliant)
- Power supply: VDD = 1.5V ± 0.075V
- Eight internal banks for concurrent operation (components)
- Interface: SSTL_15
- Burst lengths (BL): 8 and 4 with Burst Chop (BC)
- /CAS Latency (CL): 6,7,8,9
- /CAS Write latency (CWL): 5,6,7
- Precharge: Auto precharge option for each burst access
- Refresh: Auto-refresh, self-refresh
- Refresh cycles
 - Average refresh period
 - 7.8μs at 0°C ≤ TC ≤ +85°C
 - 3.9μs at +85°C < TC < +95°C
- Operating case temperature range
 - TC = 0°C to +95°C
- Serial presence detect (SPD)
- VDDSPD = 3.0V to 3.6V

Features

- Double-data-rate architecture; two data transfers per clock cycle.
- The high-speed data transfer is realized by the 8 bits prefetch pipelined architecture.
- Bi-directional differential data strobe (DQS and /DQS) is transmitted/received with data for capturing data at the receiver.
- DQS is edge-aligned with data for READs; center aligned with data for WRITEs.
- Differential clock inputs (CK and /CK)
- DLL aligns DQ and DQS transitions with CK transitions
- Commands entered on each positive CK edge; data and data mask referenced to both edges of DQS.
- Data mask (DM) for write data.
- Posted /CAS by programmable additive latency for better command and data bus efficiency.
- On-Die-Termination (ODT) for better signal quality
 - Synchronous ODT
 - Dynamic ODT
 - Asynchronous ODT
- Multi Purpose Register (MPR) for temperature read out.
- ZQ calibration for DQ drive and ODT.
- Programmable Partial Array Self-Refresh (PASR)
- /RESET pin for Power-up sequence and reset function.
- SRT range:
 - Normal/extended
 - Auto/manual self-refresh
- Programmable Output driver impedance control

Description

The [78.A2GCB.AF10C](#) is a 256MX72 DDR3 SDRAM high density SO-UDIMM. This memory module consists of eighteen CMOS 256MX8 bits with 8 banks DDR3 synchronous DRAMs in BGA packages and a 2K EEPROM in an 8-pin MLF package. This module is a 204-pin small outline dual in line memory module and is intended for mounting into a connector socket. Decoupling capacitors are mounted on the printed circuit board for each DDR3 SDRAM.

Pin Configurations

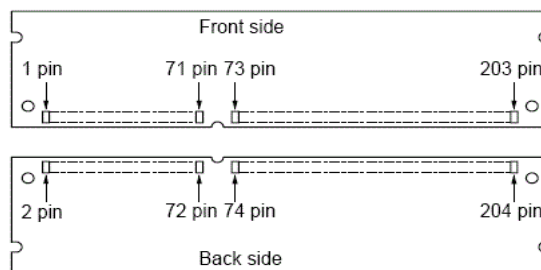

204-PIN DDR3 SO-UDIMM FRONT								204-PIN DDR3 SO-UDIMM BACK							
Pin	Name	Pin	Name	Pin	Name	Pin	Name	Pin	Name	Pin	Name	Pin	Name	Pin	Name
1	VREFDQ	53	VSS	105	A1	157	DM5	2	VSS	54	DQ28	106	A2	158	VSS
3	VSS	55	DQ24	107	A0	159	DQ42	4	DQ4	56	DQ29	108	BA1	160	DQ46
5	DQ0	57	DQ25	109	VDD	161	DQ43	6	DQ5	58	VSS	110	VDD	162	DQ47
7	DQ1	59	DM3	111	CK0	163	VSS	8	VSS	60	DQS3#	112	CK1	164	VSS
9	VSS	61	VSS	113	CK0#	165	DQ48	10	DQS0#	62	DQS3	114	CK1#	166	DQ52
11	DM0	63	DQ26	115	VDD	167	DQ49	12	DQS0	64	VSS	116	VDD	168	DQ53
13	DQ2	65	DQ27	117	A10/AP	169	VSS	14	VSS	66	DQ30	118	NC/CS3#	170	VSS
15	DQ3	67	VSS	119	BA0	171	DQS6#	16	DQ6	68	DQ31	120	NC/CS2#	172	DM6
17	VSS	69	CB0	121	WE#	173	DQS6	18	DQ7	70	VSS	122	RAS#	174	DQ54
19	DQ8	71	CB1	123	VDD	175	VSS	20	VSS	72	CB4	124	VDD	176	DQ55
21	DQ9	73	VSS	125	CAS#	177	DQ50	22	DQ12	74	CB5	126	ODT0	178	VSS
23	VSS	75	DQS8#	127	CS0#	179	DQ51	24	DQ13	76	DM8	128	ODT1	180	DQ60
25	DQS1#	77	DQS8	129	CS1#	181	VSS	26	VSS	78	VSS	130	A13	182	DQ61
27	DQS1	79	VSS	131	VDD	183	DQ56	28	DM1	80	CB6	132	VDD	184	VSS
29	VSS	81	CB2	133	DQ32	185	DQ57	30	RESET#	82	CB7	134	DQ36	186	DQS7#
31	DQ10	83	CB3	135	DQ33	187	VSS	32	VSS	84	VREFCA	136	DQ37	188	DQS7
33	DQ11	85	VDD	137	VSS	189	DM7	34	DQ14	86	VDD	138	VSS	190	VSS
35	VSS	87	CKE0	139	DQS4#	191	DQ58	36	DQ15	88	A15*	140	DM4	192	DQ62
37	DQ16	89	CKE1	141	DQS4	193	DQ59	38	VSS	90	A14*	142	DQ38	194	DQ63
39	DQ17	91	BA2	143	VSS	195	VSS	40	DQ20	92	A9	144	DQ39	196	VSS
41	VSS	93	VDD	145	DQ34	197	SA0	42	DQ21	94	VDD	146	VSS	198	EVENT#*
43	DQS2#	95	A12/BC#	147	DQ35	199	VDDSPD	44	DM2	96	A11	148	DQ44	200	SDA
45	DQS2	97	A8	149	VSS	201	SA1	46	VSS	98	A7	150	DQ45	202	SCL
47	VSS	99	A5	151	DQ40	203	VTT	48	DQ22	100	A6	152	VSS	204	VTT
49	DQ18	101	VDD	153	DQ41			50	DQ23	102	VDD	154	DQS5#		
51	DQ19	103	A3	155	VSS			52	VSS	104	A4	156	DQS5		

Notes:

* These pins are not used in this module.

Pin Description

Pin name	Function
	Address input
A0 to A14	Row address A0 to A14 Column address A0 to A9
A10 (AP)	Auto precharge
A12 (/BC)	Burst chop
BA0,BA1,BA2	Bank select address
DQ0 to DQ63	Data input/output
/RAS	Row address strobe command
/CAS	Column address strobe command
/WE	Write enable
/CS0,/CS1	Chip select
CKE0,CKE1	Clock enable
CK0,CK1	Clock input
/CK0,/CK1	Differential clock input
DQS0 to DQS7,/DQS0 to /DQS7	Input and output data strobe
DM0 to DM7	Input mask
SCL	Clock input for serial PD
SDA	Data input/output for serial PD
SA0,SA1	Serial address input
VDD	Power for internal circuit
VDDSPD	Power for serial EEPROM
VREFCA	Reference voltage for CA
VREFDQ	Reference voltage for DQ
VSS	Ground
VTT	I/O termination supply for SDRAM
/RESET	Set DRAM to known state
ODT0,ODT1	ODT control
/EVENT	Temperature event pin
NC	No connection

Functional Block Diagram

Figure 2: Functional Block Diagram

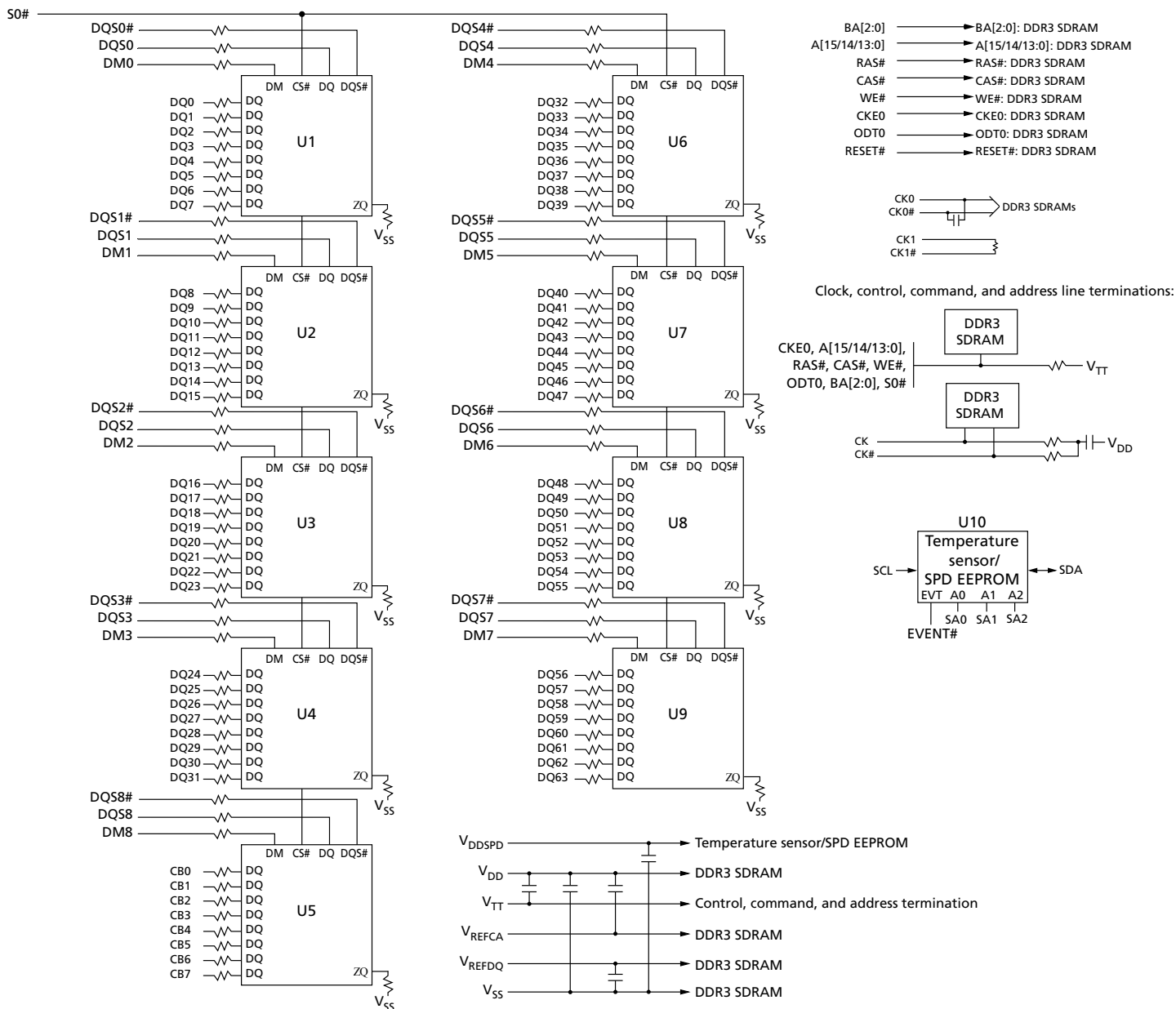

Note: 1. The ZQ ball on each DDR3 component is connected to an external 240Ω ±1% resistor that is tied to ground. It is used for the calibration of the component's ODT and output driver.

Dimensions

Unit: mm

Front side

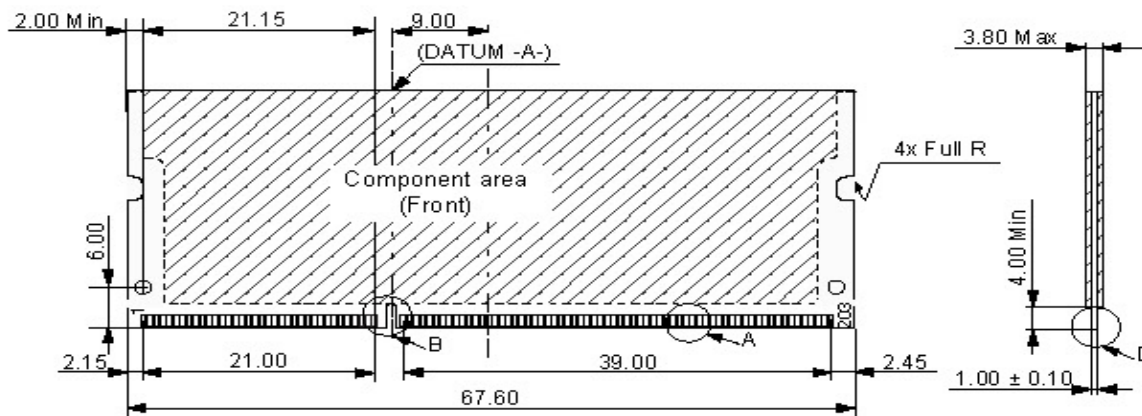

Back side

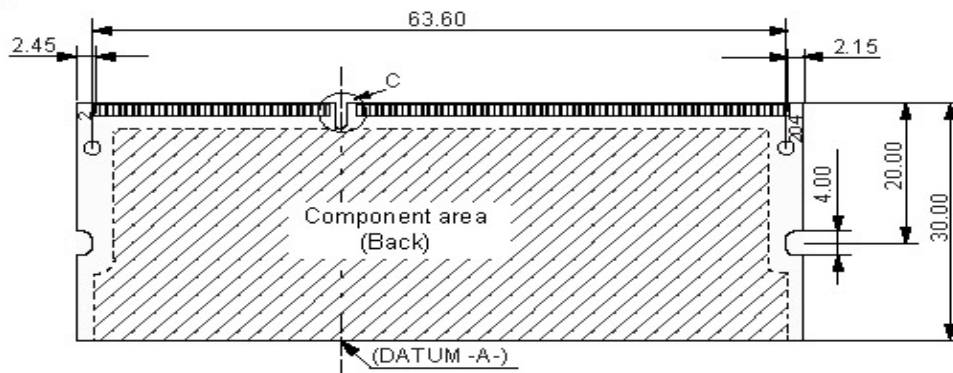

Detail A

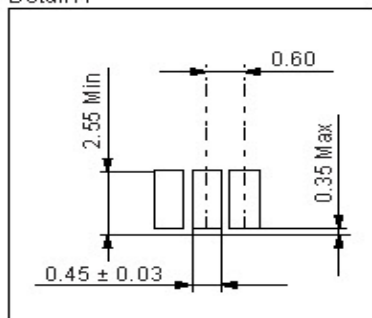

Detail B

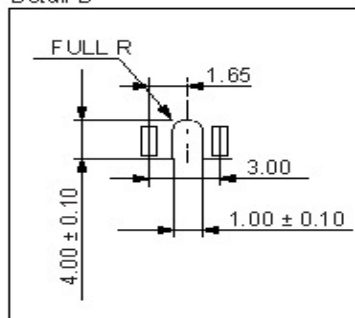

Detail C

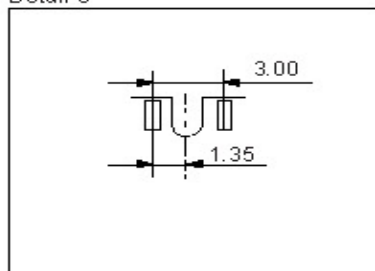

Detail D

