

MALE FACE  
SCALE: 2X

MALE BACK VIEW  
SCALE: 2X

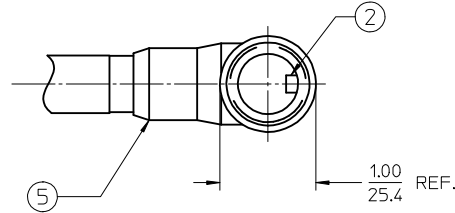

MOLD PER STD-197-02-01

BLACK #1	P1
BLACK #2	1
BLACK #3	2
GREEN/YELLOW	3
	4

WIRING DIAGRAM

NOTES:

1) PREPARE CABLE PER	STD-198-04
2) CABLE LENGTH TOLERANCES PER	S-175
3) CRIMP CONTACTS PER	S-267
4) TEST PER	S-165
5) MARK LABEL PER	S-189
6) PACKAGING INSTRUCTIONS PER	S-208
7) PACKAGE PER	S-167

PART NUMBER LEGEND

104007K21MXXXG

MC 4P SE. MALE, 90 DEG. STD. KEY  
 CABLE TYPE: 14 AWG TC ER  
 COLOR: BLACK  
 FINISHED LENGTH:  
 M001= .1M  
 M010= 1.0M  
 M100= 10.0M

7	1	WARNING LABEL
6	1	WRAP LABEL
5	1	OVERMOLD
4	1	MALE COUPLING NUT
3	4	CONTACT PIN
2	1	MALE INSERT
1	SEE LEGEND	CABLE
ITEM	QTY	DESCRIPTION

RELEASED EC NO: JGZ2017-0117 DRWINRSTONE 2016/08/02 CHKDK COX 2016/08/09 APPR: BWOODMAN 2016/08/18 REV A	QUALITY SYMBOLS ▽=0 ▽=0	GENERAL TOLERANCES (UNLESS SPECIFIED) <table border="1"> <tr> <th></th> <th>mm</th> <th>INCH</th> </tr> <tr> <td>4 PLACES</td> <td>± .005</td> <td>± .0005</td> </tr> <tr> <td>3 PLACES</td> <td>± .005</td> <td>± .0005</td> </tr> <tr> <td>2 PLACES</td> <td>± .01</td> <td>± .001</td> </tr> <tr> <td>1 PLACE</td> <td>± 0.3</td> <td>± .012</td> </tr> <tr> <td>0 PLACE</td> <td>± .005</td> <td>± .0005</td> </tr> </table> ANGULAR ± 2° DRAFT WHERE APPLICABLE MUST REMAIN WITHIN DIMENSIONS		mm	INCH	4 PLACES	± .005	± .0005	3 PLACES	± .005	± .0005	2 PLACES	± .01	± .001	1 PLACE	± 0.3	± .012	0 PLACE	± .005	± .0005	DIMENSION STYLE IN/MM DRAWN BY RSTONE DATE 2016/08/02 CHECKED BY K COX DATE 2016/08/09 APPROVED BY BWOODMAN DATE 2016/08/18 MATERIAL NO. -	SCALE 1:1 DESIGN UNITS INCH THIRD ANGLE PROJECTION	TITLE MINI-CHANGE ASSEMBLY 4P M/MP 90 DEGREE 14 AWG TPE CABLE <b>molex</b> DOCUMENT NO. 10X007K21 SHEET NO. 1 OF 1
		mm	INCH																				
	4 PLACES	± .005	± .0005																				
	3 PLACES	± .005	± .0005																				
	2 PLACES	± .01	± .001																				
1 PLACE	± 0.3	± .012																					
0 PLACE	± .005	± .0005																					
THIS DRAWING CONTAINS INFORMATION THAT IS PROPRIETARY TO MOLEX INCORPORATED AND SHOULD NOT BE USED WITHOUT WRITTEN PERMISSION																							

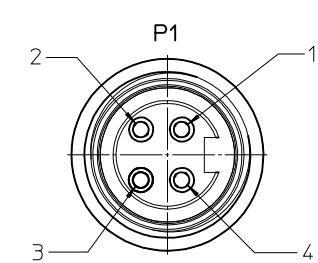
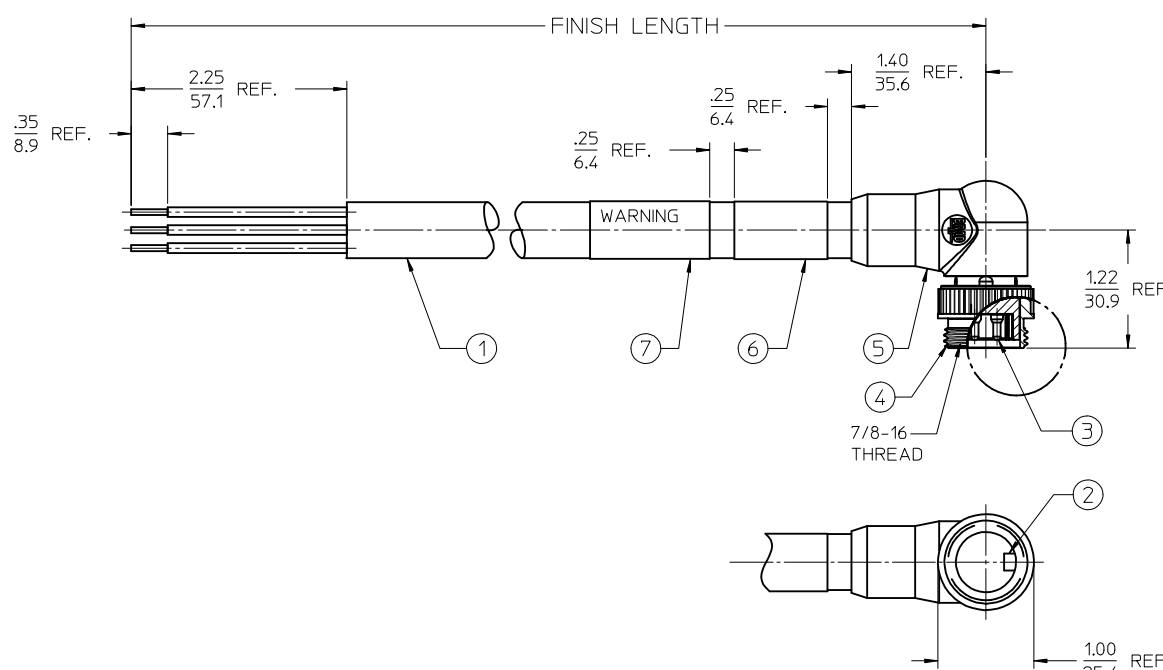

MALE FACE  
SCALE: 2X

BLACK #1	P1
BLACK #2	1
BLACK #3	2
GREEN/YELLOW	3
	4

WIRING DIAGRAM

PART NUMBER LEGEND

104007K21MXXXG

MC 4P SE. MALE, 90 DEG. STD. KEY

CABLE TYPE: 14 AWG TC ER

COLOR: BLACK

FINISHED LENGTH:  
M001= .1M  
M010= 1.0M  
M100= 10.0M

NOTES:

- MATERIAL: SEE TABLE
- FINISHES: SEE TABLE
- WRAP LABEL IS MARKED WITH P/N, DATE CODE VOLTAGE & AMPERAGE
- MATES WITH: MINI CHANGE 4 POLE RECEPTACLE, STANDARD-KEY
- ELECTRICAL DATA:  
14AWG UL TYPE: TC-ER  
POLES: 4  
MAX VOLTAGE: 600V  
MAX CURRENT: 15A  
PROTECTION IP67 (WHEN MATED)  
TEMPERATURE RANGE: -20°C TO 90°C
- PACKAGING:  
CABLE ASSEMBLIES ARE BAGGED SEPERATLY IN POLY BAGS WITH BAR CODE LABEL ATTACHED TO OUTSIDE OF BAG.

7	1	WARNING LABEL	VINYL	ORANGE/BLACK
6	1	WRAP LABEL	VINYL	BLACK/YELLOW
5	1	OVERMOLD	PVC	BLACK
4	1	MALE COUPLING NUT	ZINC ALLOY	BLACK
3	4	CONTACT PIN	CU ALLOY	GOLD PLATE
2	1	MALE INSERT	PVC	BLACK
1	SEE LEGEND	CABLE, 14/4	TPE	BLACK
ITEM	QTY	DESCRIPTION	MATERIAL	FINISH

RELEASED	EC NO: JGZ2017-0117	2016/08/01
DRWRNSTONE	2016/08/09	
CHKDK COX	2016/08/18	
APPR: BWOODMAN		
DESCRIPTION		
REV		

QUALITY SYMBOLS	GENERAL TOLERANCES (UNLESS SPECIFIED)
▽=0	
▽=0	
	mm INCH
	4 PLACES ± --- ± ---
	3 PLACES ± --- ± ---
	2 PLACES ± --- ± .01
	1 PLACE ± 0.3 ± ---
	0 PLACE ± --- ± ---
	ANGULAR ± 2 °
	DRAFT WHERE APPLICABLE MUST REMAIN WITHIN DIMENSIONS

DIMENSION STYLE	SCALE	DESIGN UNITS
IN/MM	1:1	INCH
DRAWN BY	DATE	TITLE
RSTONE	2016/08/01	MINI-CHANGE ASSEMBLY 4P M/MP 90 DEGREE 14 AWG TPE CABLE
CHECKED BY	DATE	
K COX	2016/08/09	<b>molex</b>
APPROVED BY	DATE	
BWOODMAN	2016/08/18	DOCUMENT NO.
MATERIAL NO.	-	SD-130061-040

THIRD ANGLE PROJECTION	SHEET NO.
	1 OF 1
THIS DRAWING CONTAINS INFORMATION THAT IS PROPRIETARY TO MOLEX INCORPORATED AND SHOULD NOT BE USED WITHOUT WRITTEN PERMISSION	