

ASSP for Power Supply Applications

6MHz Synchronous Rectification Buck-Boost DC/DC Converter IC MB39C326

■ DESCRIPTION

The MB39C326 is a high efficiency, low noise synchronous, Buck-boost DC/DC converter designed for powering the radio frequency power amplifiers (RFPA) in 3G/GSM mobile handsets and other mobile applications. It provides up to 800 mA of output current over an input voltage range of 2.5 V to 5.5 V. The maximum average current in the switches is limited to a typical value of 2000 mA.

■ FEATURES

- High efficiency : Up to 95%
- Input voltage range : 2.5 V to 5.5 V
- Adjustable output voltage range : 0.4 V to 5.0 V
- Input current limit value : 2A/1A/0.5A
- Output current : 1200mA (Buck, output at 3.3V)
: 800mA (Boost, output at 3.3V)
- Quiescent current : 50 μ A
- 6MHz PWM operation allows 0.5 μ H small form inductor
- Less than 20 μ s step response for 3G
- Automatic Transition between Buck mode and boost mode
- Power-Save Mode for improved efficiency at light load current
- Selectable output voltage with external resistor
- Built-in Over temperature protection circuit
- Built-in Under voltage lockout protection circuit
- Package : WL-CSP (20pin 0.4 mm-ball-pitch 2.15 \times 1.94 mm)

■ APPLICATIONS

- Products that use 1-cell lithium batteries for the power supply
- RF power amplifier
- Cell-phone
- RF-PC card and PDA

■ PIN ASSIGNMENTS

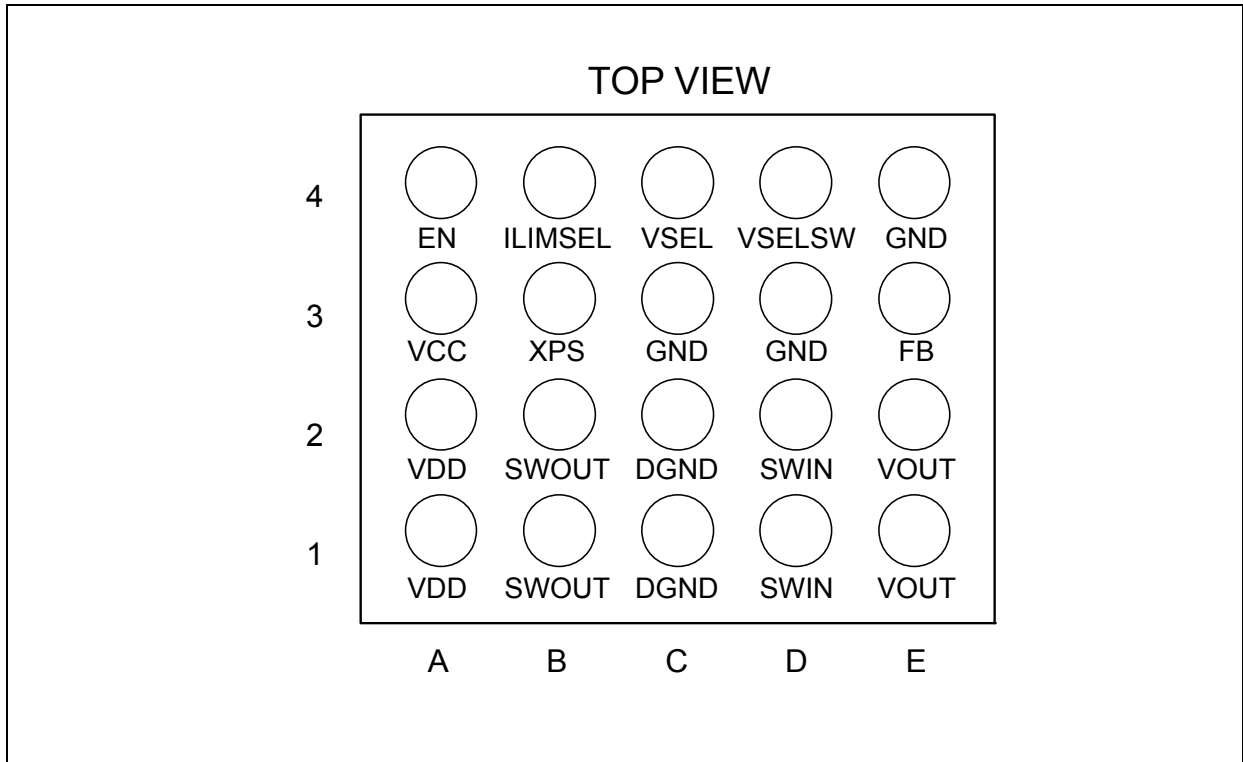

■ PIN DISCRIPTIONS

Pin No.	Pin Name	I/O	Description
A4	EN	I	IC Enable input pin (H: Enable, L: Shutdown)
E3	FB	I	Voltage feedback pin
C3,D3,E4	GND		Control / Logic ground pins
B4	ILIMSEL	I	Current limit mode pin
B1,B2	SWOUT	I	Connection pins for Inductor
D1,D2	SWIN	I	Connection pins for Inductor
C1,C2	DGND		Power ground pins
C4	VSEL	I	Output voltage select pin (H:Using R3 L:No using R3)
D4	VSELSW		Connection pin for output voltage setting resistor R3
A1,A2	VDD	I	Electric power input pin for DCDC converter output voltage
A3	VCC	I	Electric power input pin for IC control block
B3	XPS	I	Power save mode pin (H: Normal mode, L: Power save mode)
E1,E2	VOUT	O	Buck-boost converter output pins

■ BLOCK DIAGRAM

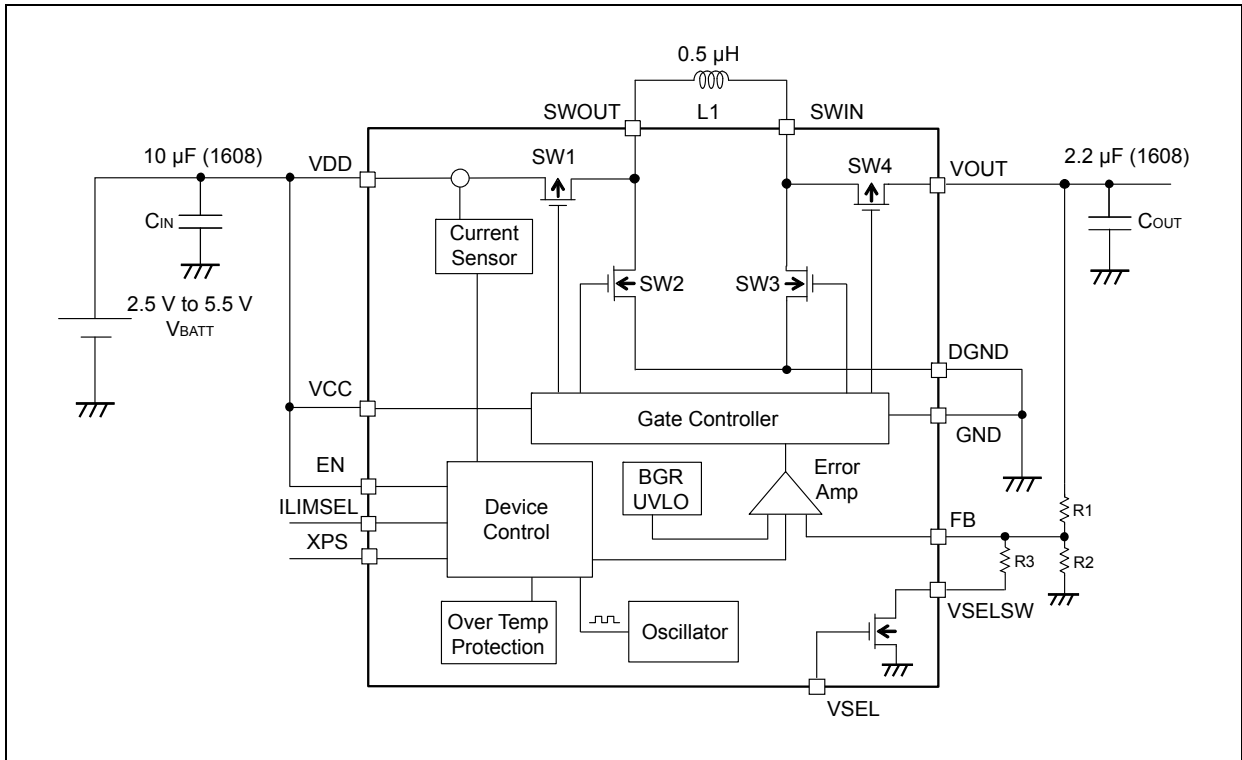

■ FUNCTION

(1) Gate Controller

It is controlled the synchronous rectification operation of built-in 2-P-ch MOS FETs and 2-N-ch MOS FETs according to frequency (6 MHz) set with a oscillator at the normal operation.

(2) Error Amp & phase compensation circuit

This compares the feedback voltage and the reference voltage (VREF). This IC contains the phase compensation circuit which optimizes the IC operation. Therefore, it is unnecessary to consideration of the phase compensation circuit, and external parts for the phase compensation.

(3) Band gap reference circuit

A high accuracy reference voltage is generated with BGR (band gap reference) circuit.

(4) Oscillator

The internal oscillator output a 6 MHz clock signal to set a switching frequency.

(5) Over temperature protection circuit

The over temperature protection circuit is built-in as a protection circuit. When junction temperature reaches +125°C, the over temperature protection circuit turns off all N-ch MOS FETs and P-ch MOS FETs. Also, when the junction temperature falls to +110°C, this IC operates normally.

(6) Over current protection circuit (Current Sensor + Device Control)

The over current protection circuit detects the current (I_{LX}) which flows from built-in P-ch MOS FET connected to VDD into an external inductor. The over current protection circuit controls the peak value of current.

(7) Power save mode operation

Power Save mode is used to improve efficiency at the light load. The XPS pin should be set at low to enable power save mode. When the load current is lower than 300 mA, this IC operates with PFM (Pulse Frequency Modulation). It should be used above $V_{OUT}=0.8$ V. If the output voltage becomes lower than the setting value at the light load, switching is performed several times and the output voltage rises. If the output voltage reaches the setting value, it changes to the stop state, all of the four FETs are turned off, and the switching loss and the consumption power for the circuit are suppressed.

• Function Table

Mode	XPS	ILIMSEL	Input voltage range[V]		Output voltage range[V]		Current limit [A]
			Min	Max	Min	Max	
PWM mode	H	H	3.1	4.8	0.4	4.2	2.0
		L	2.5	5.5	0.8	5.0	
Power save mode	L	H					2.5
		L	0.5				

■ ABSOLUTE MAXIMUM RATINGS

Parameter	Symbol	Condition	Rating		Unit
			Min	Max	
Power supply voltage	V_{MAX}	VDD, VCC	-0.3	+7.0	V
Signal input voltage	V_{INMAX}	EN, XPS, VSEL, ILIMSEL	-0.3	$V_{DD}+0.3$	V
Power dissipation	P_D	-	-	1080	mW
Storage temperature	T_{STG}	-	-65	+150	°C
ESD Voltage	V_{ESDH}	Human Body Model (100 pF, 1.5 kΩ)	-1000	+1000	V
	V_{ESDM}	Machine Model (200 pF, 0Ω)	-200	+200	V
	V_{ESDC}	Charged device model	-1	+1	kV

WARNING: Semiconductor devices can be permanently damaged by application of stress (voltage, current, temperature, etc.) in excess of absolute maximum ratings. Do not exceed these ratings.

■ RECOMMENDED OPERATING CONDITIONS

Parameter	Symbol	Condition	Value			Unit
			Min	Typ	Max	
Power supply voltage	V_{DD}	VDD, VCC	2.5*	3.7	5.5*	V
Signal input voltage	V_{IDD}	EN, XPS, VSEL, ILIMSEL	0.0	-	V_{DD}	V
Operating Ambient temperature	T_a	-	-40	-	+85	°C
Inductor value	L	-	-	0.5	-	μH

* : Depending on the setting condition. See "•Function Table" in "■FUNCTION (7) Power save mode operation".

WARNING: The recommended operating conditions are required in order to ensure the normal operation of the semiconductor device. All of the device's electrical characteristics are warranted when the device is operated within these ranges.

Always use semiconductor devices within their recommended operating condition ranges.

Operation outside these ranges may adversely affect reliability and could result in device failure.

No warranty is made with respect to uses, operating conditions, or combinations not represented on the data sheet. Users considering application outside the listed conditions are advised to contact their representatives beforehand.

■ ELECTRICAL CHARACTERISTICS

The specifications apply under the recommended operating condition.

Parameter	Symbol	Condition	Value			Unit
			Min	Typ	Max	
Input voltage	V _{IN}	XPS=L/XPS = H, ILIMSEL = L	2.5	3.7	5.5	V
		XPS = H, ILIMSEL = H	3.1	-	4.8	
Output voltage	V _{OUT}	XPS = L/XPS = H, ILIMSEL = L	0.8	-	5.0	V
		XPS = H, ILIMSEL = H	0.4	-	4.2	
Feedback voltage	V _{FB}	-	-	500*	-	mV
Maximum output current	I _{OUT}	V _{IN} = 2.5 V, V _{OUT} = 4.5 V	800	-	-	mA
Line Regulation	V _{LINE}	I _{OUT} = 0 to I _{OMAX}	-	-	10	mV
Load Regulation	V _{LOAD}	I _{OUT} = 0 to I _{OMAX}	-	-	20	mV
Output current limit	I _{PK}	SWOUT	2.0	2.5	3.0	A
Input current limit	I _{LIMIT}	XPS=H	-	2.0*	-	A
		XPS=L, ILIMSEL = H	-	1.0*	-	A
		XPS=L, ILIMSEL = L	-	0.5*	-	A
Oscillation frequency	f _{OSC}	-	-	6*	-	MHz
Shutdown current	I _{SD}	EN = L	-	-	2	μA
Quiescent current	I _Q	EN = H, XPS = L, V _{IN} = 3.7 V, V _{OUT} = 3.4 V, I _{OUT} = 0 mA	-	50	-	μA
Over temperature protection	T _{OTPH}	-	-	135*	-	°C
	T _{OTPL}	-	-	110*	-	°C
UVLO Threshold voltage	V _{UVLOH}	-	-	2.0*	-	V
	V _{UVLOL}	-	-	1.9*	-	V
Signal input threshold voltage	V _{IL}	EN, XPS, VSEL, ILIMSEL	0.0	-	V _{DD} ×0.3	V
	V _{IH}	EN, XPS, VSEL, ILIMSEL	V _{DD} ×0.7	-	V _{DD}	V
Signal input current	I _{CTL}	EN, XPS, VSEL, ILIMSEL	-	-	0.1	μA

*: This parameter is not be specified. This should be used as a reference to support designing the circuits.

■ TYPICAL APPLICATIONS CIRCUIT

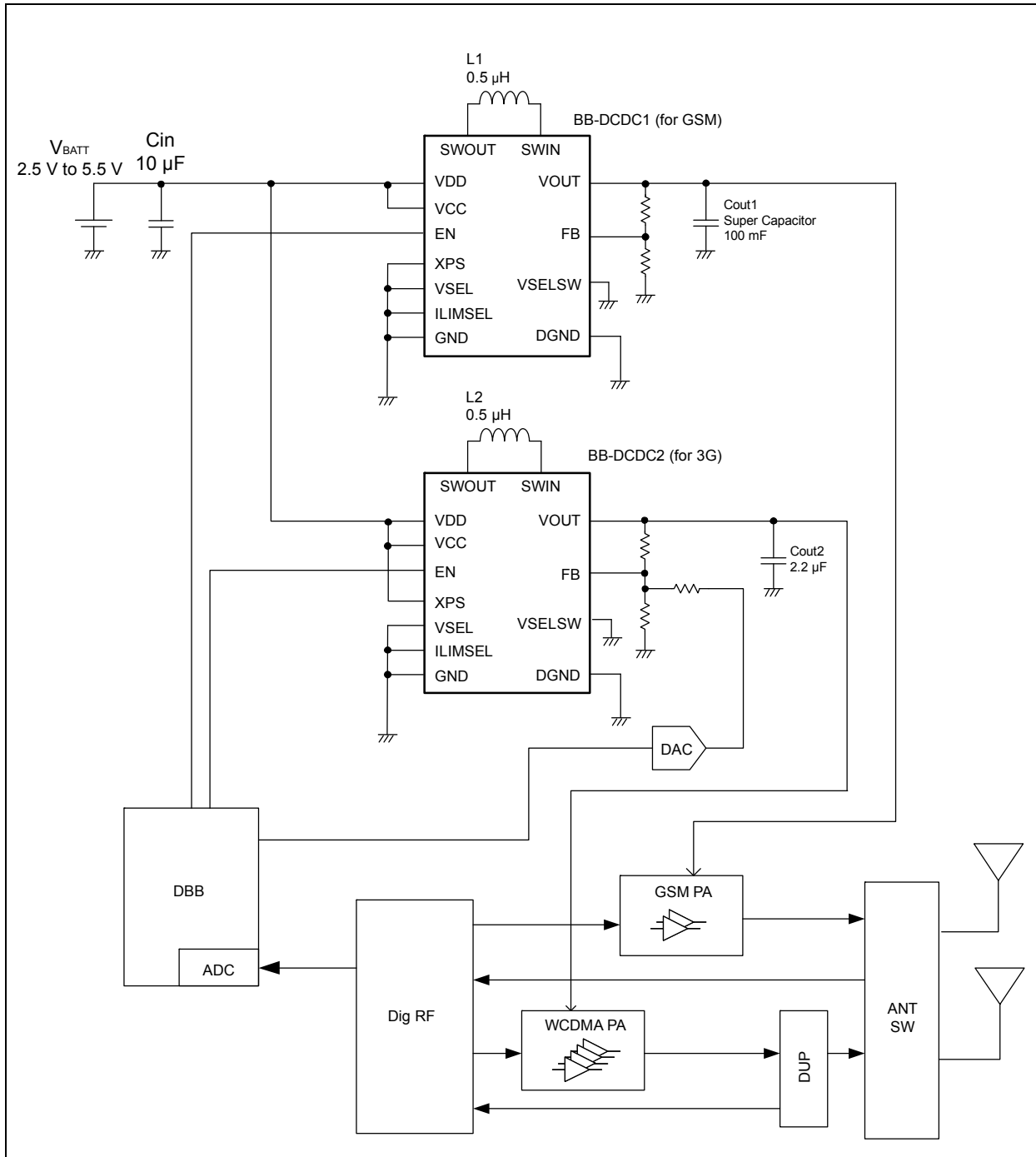

■ APPLICATION NOTES

● Programming the Output Voltage

Output voltage is calculated using the equation (1) below.

Use R1 resistor value of 620 kΩ. Built-in phase compensation circuit is generated according to this resistor value.

(1) Not using a selectable voltage option

$$V_{OUT} = V_{FB} \times \frac{R_1 + R_2}{R_2}$$

($V_{FB} = 500 \text{ mV}$)

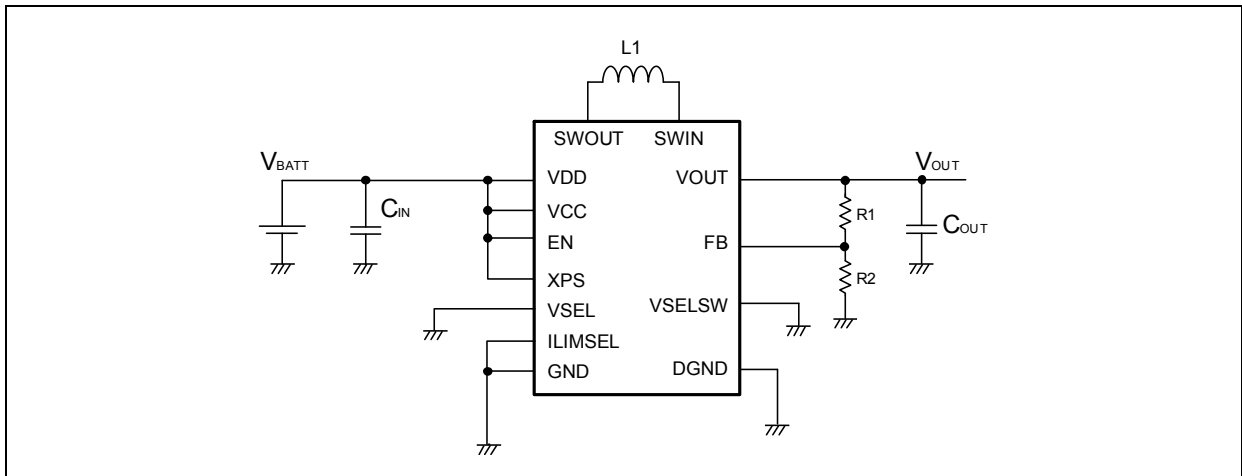

(2) Using a selectable voltage option

When VSEL=L

$$V_{OUT} = V_{FB} \times \frac{R_1 + R_2}{R_2}$$

When VSEL=H

$$V_{OUT} = V_{FB} \times \frac{R_1 + (R_2 \parallel R_3)}{R_2 \parallel R_3}$$

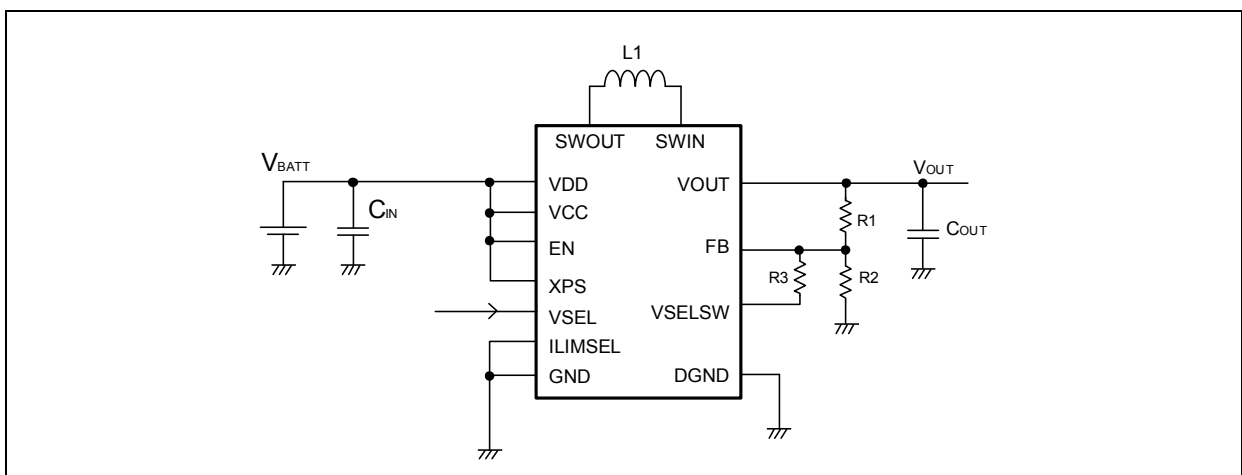

(3) When the output variable is dynamically performed

$$V_O = -\frac{R_1}{R_3} \times V_{DAC} + V_{FB} \times \left(\frac{R_1}{R_3} + \frac{R_1}{R_2} + 1 \right)$$

($V_{FB} = 500\text{mV}$)

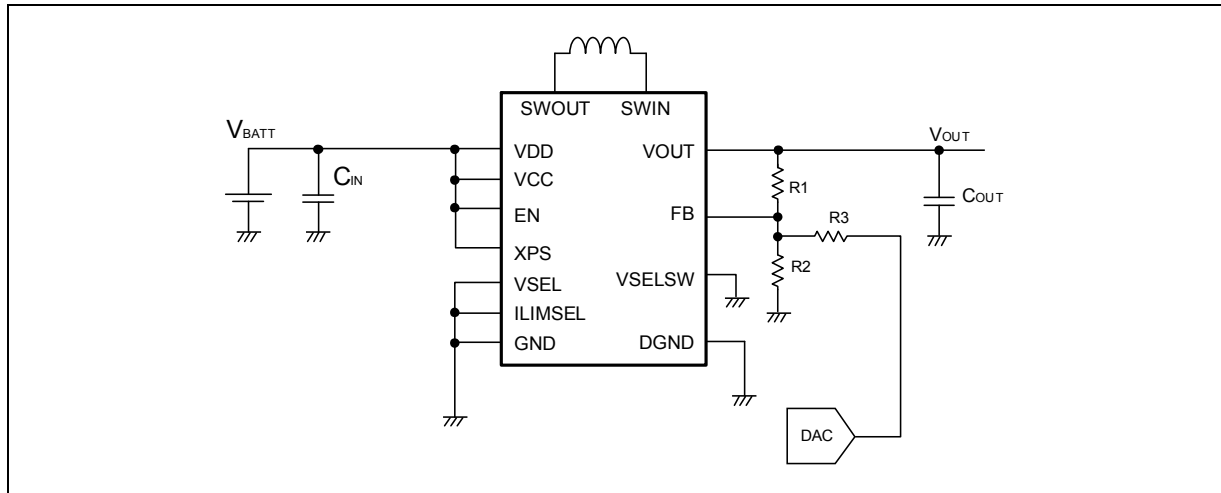

● Relationship between DAC and output when setting to $R_1=620\text{k}\Omega$, $R_2=110\text{k}\Omega$ and $R_3=330\text{k}\Omega$

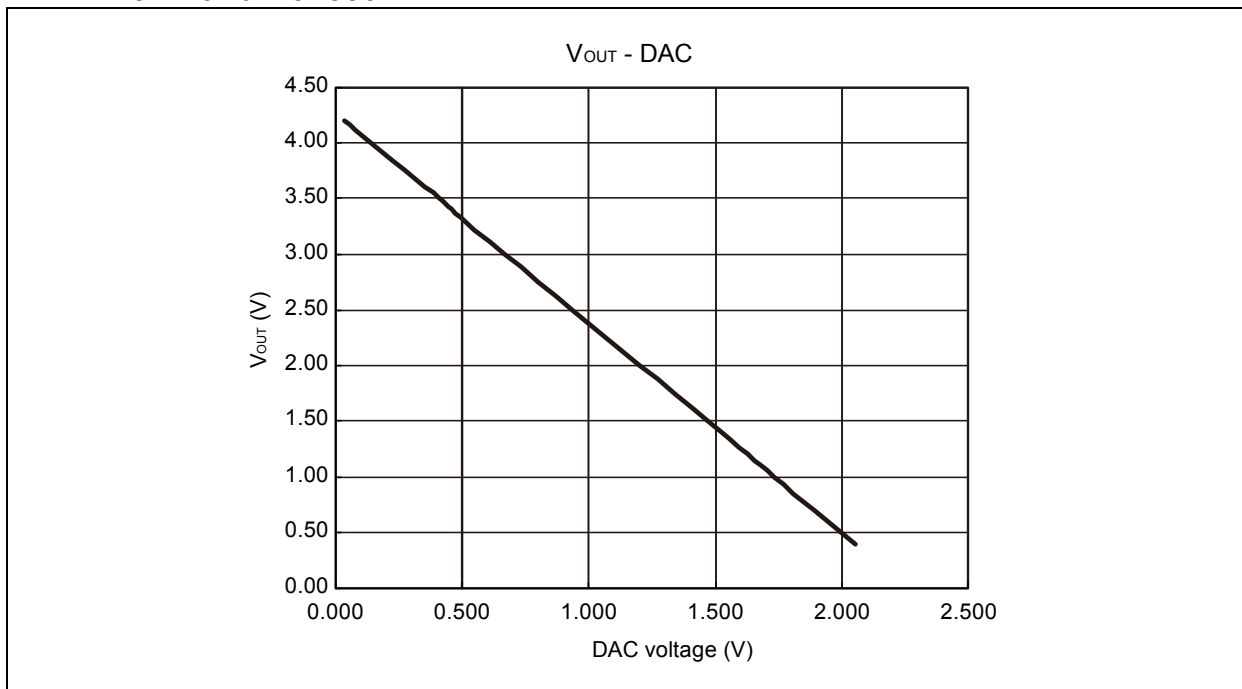

■ EXAMPLE OF STANDARD OPERATION CHARACTERISTICS

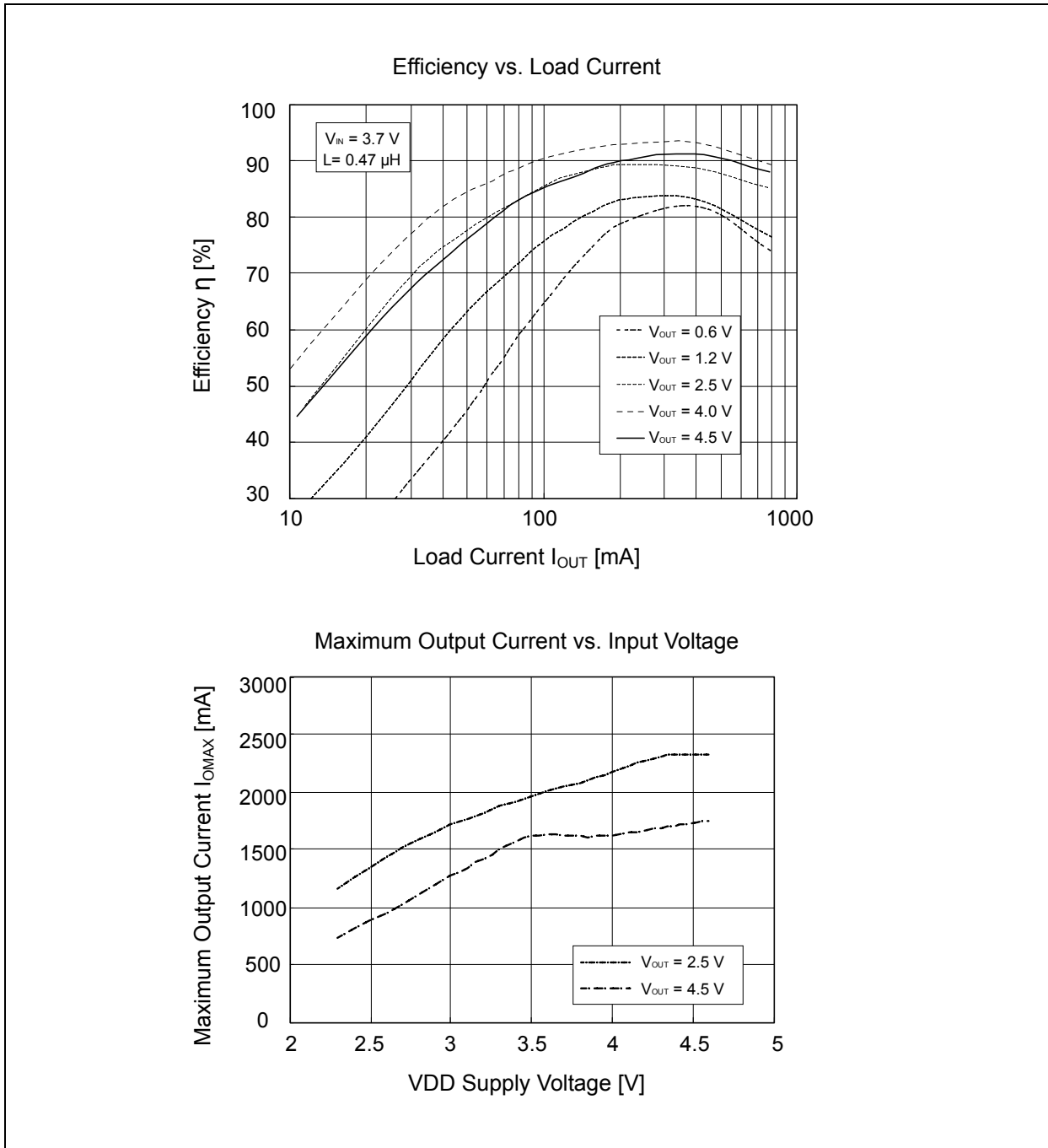

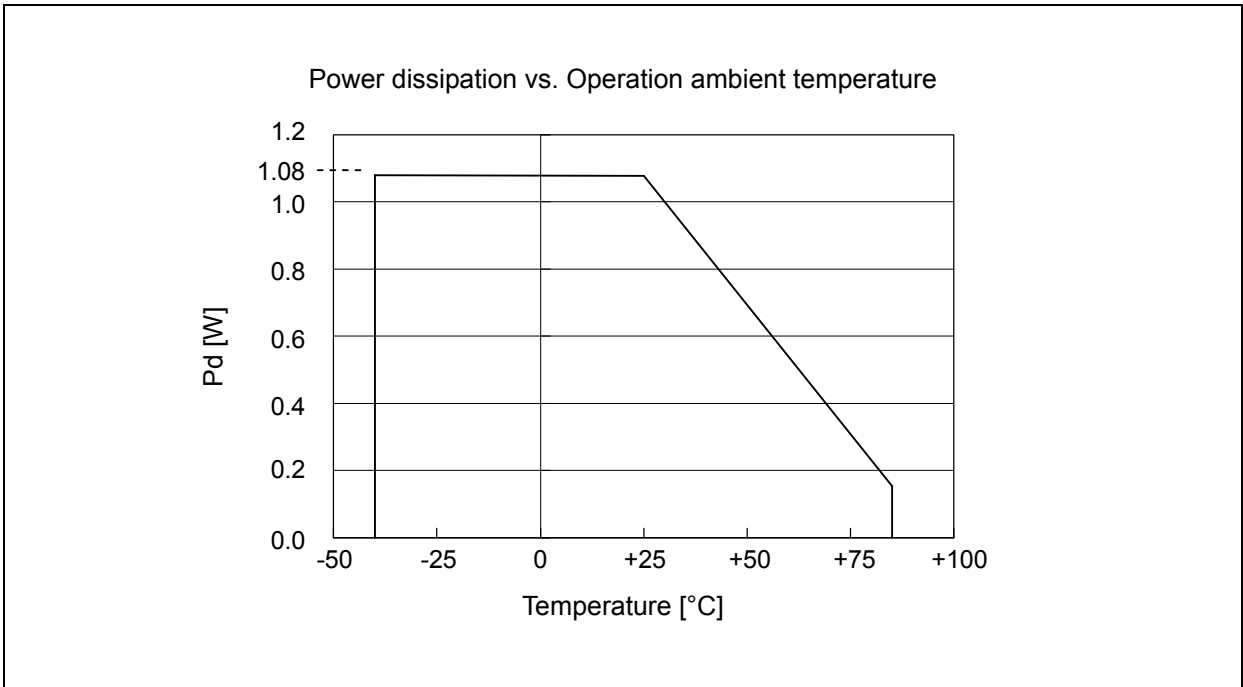

■ USAGE PRECAUTION

1. Do not configure the IC over the maximum ratings.

If the IC is used over the maximum ratings, the LSI may be permanently damaged.

It is preferable for the device to be normally operated within the recommended usage conditions. Usage outside of these conditions can have a bad effect on the reliability of the LSI.

2. Use the devices within recommended operating conditions.

The recommended operating conditions are the recommended values that guarantee the normal operations of LSI.

The electrical ratings are guaranteed when the device is used within the recommended operating conditions and under the conditions stated for each item.

3. Printed circuit board ground lines should be set up with consideration for common impedance.

4. Take appropriate measures against static electricity.

- Containers for semiconductor materials should have anti-static protection or be made of conductive material.
- After mounting, printed circuit boards should be stored and shipped in conductive bags or containers.
- Work platforms, tools, and instruments should be properly grounded.
- Working personnel should be grounded with resistance of 250 k Ω to 1 M Ω in series between body and ground.

5. Do not apply negative voltages.

The use of negative voltages below -0.3 V may cause the parasitic transistor to be activated on LSI lines, which can cause malfunctions.

■ ORDERING INFORMATION

Part number	Package	Remarks
MB39C326PW	20-pin plastic WLP (WLP-20P-M01)	

■ EV BOARD ORDERING INFORMATION

EV board number	EV board version No.	Remarks
MB39C326-EVB-01	MB39C326-EVB-01 REV5.0	20pin-WL-CSP

■ RoHS COMPLIANCE INFORMATION OF LEAD (Pb) FREE VERSION

The LSI products of FUJITSU SEMICONDUCTOR with "E1" are compliant with RoHS Directive, and has observed the standard of lead, cadmium, mercury, Hexavalent chromium, polybrominated biphenyls (PBB), and polybrominated diphenyl ethers (PBDE). A product whose part number has trailing characters "E1" is RoHS compliant.

■ LABELING SAMPLE (Lead free version)

Lead-free mark

JEITA logo

JEDEC logo

MB123456P - 789 - GE1
(3N) 1MB123456P-789-GE1 1000

QC PASS

1,000 PCS
MB123456P - 789 - GE1

2006/03/01 ASSEMBLED IN JAPAN

MB123456P - 789 - GE1
1561190005 1/1 0605 - Z01A 1000

The part number of a lead-free product has the trailing characters "E1".

"ASSEMBLED IN CHINA" is printed on the label of a product assembled in China.

■ MB39C326PW RECOMMENDED CONDITIONS OF MOISTURE SENSITIVITY LEVEL

[FUJITSU SEMICONDUCTOR Recommended Mounting Conditions]

Item	Condition	
Mounting Method	IR (infrared reflow), warm air reflow	
Mounting times	2 times	
Storage period	Before opening	Please use it within two years after manufacture.
	From opening to the 2nd reflow	
Storage conditions	5°C to 30°C, 70% RH or less (the lowest possible humidity)	

[Parameters for Each Mounting Method]

IR (infrared reflow)

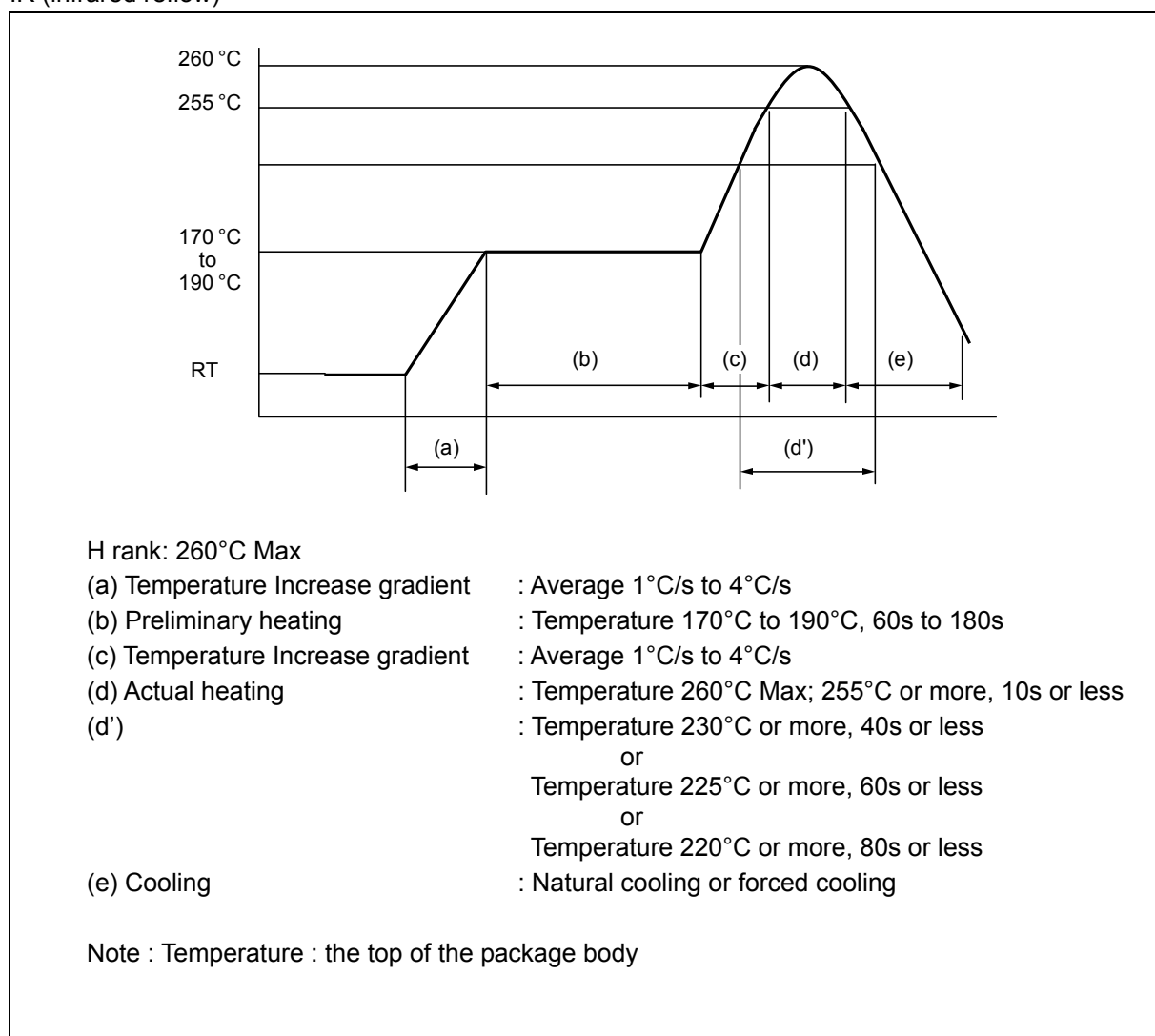

■ PACKAGE DIMENSIONS

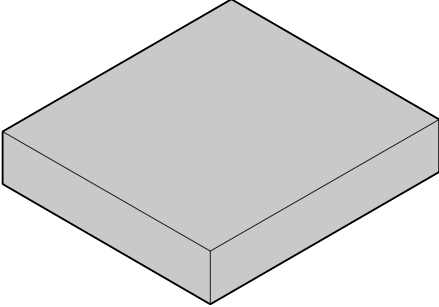
<p>20-pin plastic WLP</p>  <p>(WLP-20P-M01)</p>	Lead pitch	0.4 mm
	Package width × package length	2.15 mm × 1.94
	Lead shape	Soldering ball
	Sealing method	Print
	Mounting height	0.625 mm Max.
	Weight	0.005 g
	Code (Reference)	S-WF BGA20-2.15 × 1.94-0.40

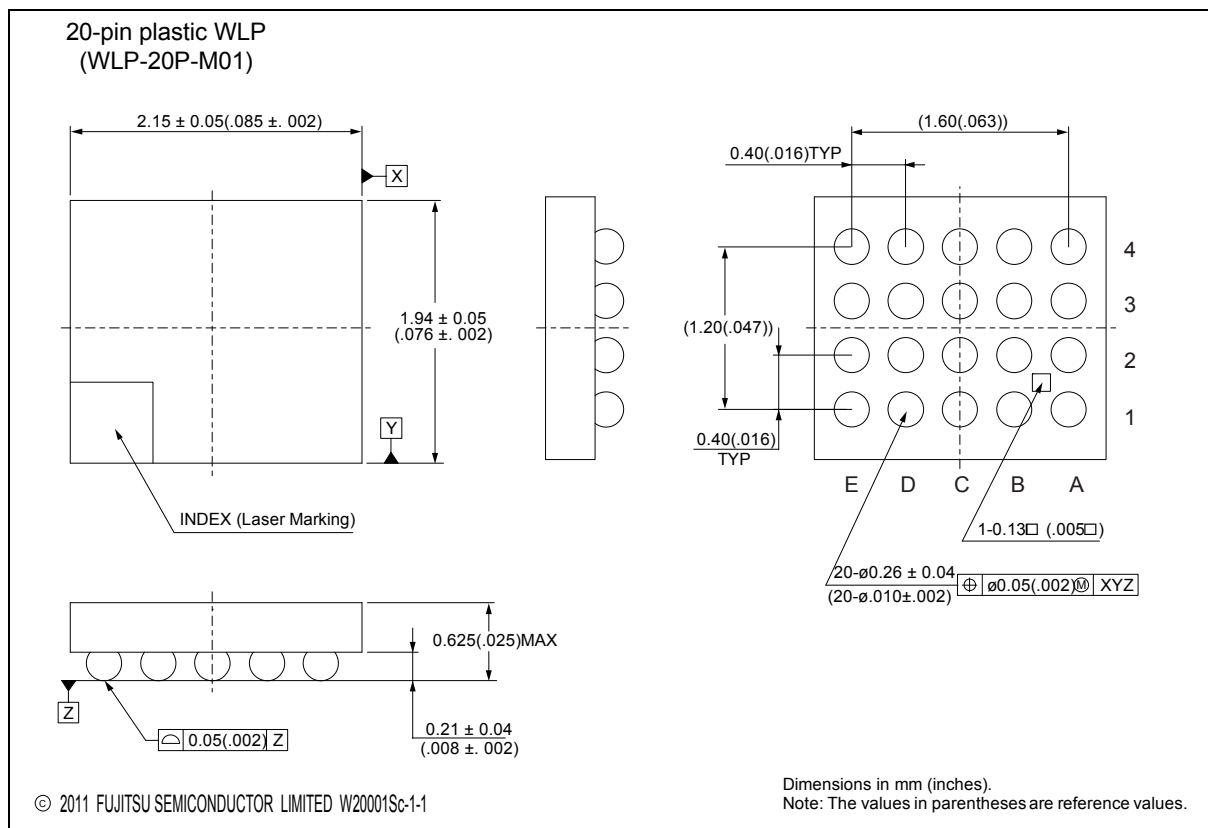

Please check the latest package dimension at the following URL.
<http://edevice.fujitsu.com/package/en-search/>

MEMO

MEMO

MEMO

FUJITSU SEMICONDUCTOR LIMITED

Nomura Fudosan Shin-yokohama Bldg. 10-23, Shin-yokohama 2-Chome,
Kohoku-ku Yokohama Kanagawa 222-0033, Japan

Tel: +81-45-415-5858

<http://jp.fujitsu.com/fsl/en/>

For further information please contact:

North and South America

FUJITSU SEMICONDUCTOR AMERICA, INC.

1250 E. Arques Avenue, M/S 333

Sunnyvale, CA 94085-5401, U.S.A.

Tel: +1-408-737-5600 Fax: +1-408-737-5999

<http://us.fujitsu.com/micro/>

Asia Pacific

FUJITSU SEMICONDUCTOR ASIA PTE. LTD.

151 Lorong Chuan,

#05-08 New Tech Park 556741 Singapore

Tel : +65-6281-0770 Fax : +65-6281-0220

<http://sg.fujitsu.com/semiconductor/>

Europe

FUJITSU SEMICONDUCTOR EUROPE GmbH

Pittlerstrasse 47, 63225 Langen, Germany

Tel: +49-6103-690-0 Fax: +49-6103-690-122

<http://emea.fujitsu.com/semiconductor/>

FUJITSU SEMICONDUCTOR SHANGHAI CO., LTD.

30F, Kerry Parkside, 1155 Fang Dian Road,

Pudong District, Shanghai 201204, China

Tel : +86-21-6146-3688 Fax : +86-21-6146-3660

<http://cn.fujitsu.com/fss/>

Korea

FUJITSU SEMICONDUCTOR KOREA LTD.

902 Kosmo Tower Building, 1002 Daechi-Dong,

Gangnam-Gu, Seoul 135-280, Republic of Korea

Tel: +82-2-3484-7100 Fax: +82-2-3484-7111

<http://kr.fujitsu.com/fsk/>

FUJITSU SEMICONDUCTOR PACIFIC ASIA LTD.

10/F., World Commerce Centre, 11 Canton Road,

Tsimshatsui, Kowloon, Hong Kong

Tel : +852-2377-0226 Fax : +852-2376-3269

<http://cn.fujitsu.com/fsp/>

Specifications are subject to change without notice. For further information please contact each office.

All Rights Reserved.

The contents of this document are subject to change without notice.

Customers are advised to consult with sales representatives before ordering.

The information, such as descriptions of function and application circuit examples, in this document are presented solely for the purpose of reference to show examples of operations and uses of FUJITSU SEMICONDUCTOR device; FUJITSU SEMICONDUCTOR does not warrant proper operation of the device with respect to use based on such information. When you develop equipment incorporating the device based on such information, you must assume any responsibility arising out of such use of the information.

FUJITSU SEMICONDUCTOR assumes no liability for any damages whatsoever arising out of the use of the information. Any information in this document, including descriptions of function and schematic diagrams, shall not be construed as license of the use or exercise of any intellectual property right, such as patent right or copyright, or any other right of FUJITSU SEMICONDUCTOR or any third party or does FUJITSU SEMICONDUCTOR warrant non-infringement of any third-party's intellectual property right or other right by using such information. FUJITSU SEMICONDUCTOR assumes no liability for any infringement of the intellectual property rights or other rights of third parties which would result from the use of information contained herein.

The products described in this document are designed, developed and manufactured as contemplated for general use, including without limitation, ordinary industrial use, general office use, personal use, and household use, but are not designed, developed and manufactured as contemplated (1) for use accompanying fatal risks or dangers that, unless extremely high safety is secured, could have a serious effect to the public, and could lead directly to death, personal injury, severe physical damage or other loss (i.e., nuclear reaction control in nuclear facility, aircraft flight control, air traffic control, mass transport control, medical life support system, missile launch control in weapon system), or (2) for use requiring extremely high reliability (i.e., submersible repeater and artificial satellite).

Please note that FUJITSU SEMICONDUCTOR will not be liable against you and/or any third party for any claims or damages arising in connection with above-mentioned uses of the products.

Any semiconductor devices have an inherent chance of failure. You must protect against injury, damage or loss from such failures by incorporating safety design measures into your facility and equipment such as redundancy, fire protection, and prevention of over-current levels and other abnormal operating conditions.

Exportation/release of any products described in this document may require necessary procedures in accordance with the regulations of the Foreign Exchange and Foreign Trade Control Law of Japan and/or US export control laws.

The company names and brand names herein are the trademarks or registered trademarks of their respective owners.