

NOTES:

1. MATERIALS AND FINISHES:

- BODY - ZINC DIE CAST, TIN PLATED
- NUT & WASHER - BRASS, NICKEL PLATED
- CONTACT - PHOSPHOR BRONZE, TIN PLATED
- LOCKWASHER - PHOSPHOR BRONZE, NICKEL PLATED
- CAP - BRASS, NICKEL PLATED
- MEMBRANE SEAL - SILICONE RUBBER
- INSULATOR - PTFE

2. ELECTRICAL:

- A. IMPEDANCE = 75 OHM, NOMINAL
- B. FREQUENCY RANGE = DC - 2.15 GHz
- C. VSWR(RETURN LOSS) = 1.43 (15 dB), MAX. AT 1 GHz,
1.93 (10 dB) MAX. AT 2.15 GHz
- D. INSERTION LOSS = 0.2 dB MAX. AT 1 GHz
0.46 dB MAX AT 2.15 GHz
- E. CURRENT RATING = 3A MAX.

3. MECHANICAL:

- A. DURABILITY = 500 CYCLES MIN.
- B. TEMPERATURE RANGE = -65° C TO +165° C
- C. SHORT DURATION TEMPERATURE = +260° C MAX
- D. INTERFACE = MATES WITH PLUGS I.A.W. SCTE
- E. IP67 IN THE UNMATED CONDITION

4. PACKAGING:

- A. QUANTITY: SINGLE PACK
- B. BAG MARKING: AMPHENOL
531-40165
DATE CODE (YYWW)

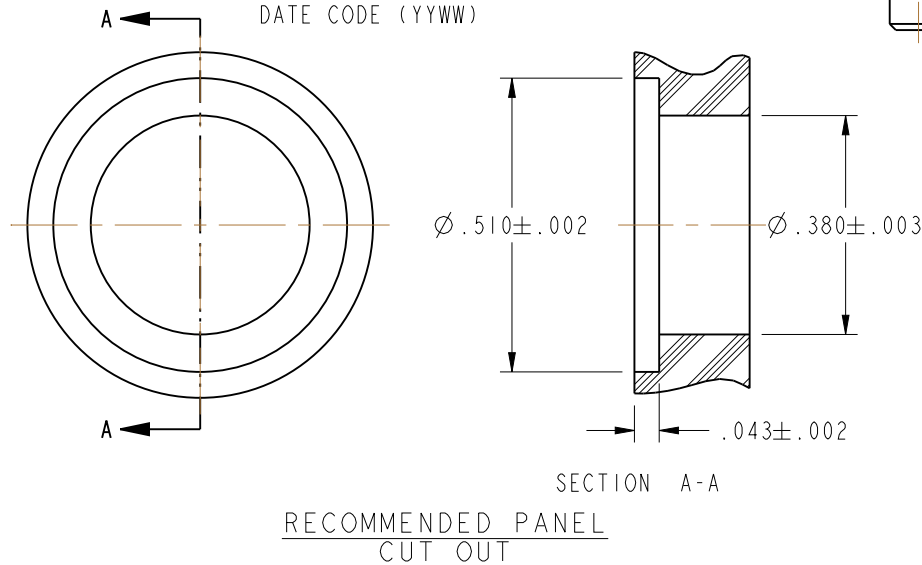

CUSTOMER OUTLINE DRAWING
ALL OTHER SHEETS ARE FOR INTERNAL USE ONLY

THIRD ANGLE PROJ.

REVISIONS

REV	DESCRIPTION	DATE	ECO	APPR
A	RELEASE TO MFG	10/6/03	44634	
B	ADDED VSWR SPEC TO 2.15 GHz, ADDED IP67 NOTE	4/16/13	49503	DD
C	ADDED EXPLODED VIEW, REVISED NOTE 7-B & BOM	3/20/15	50386	JN

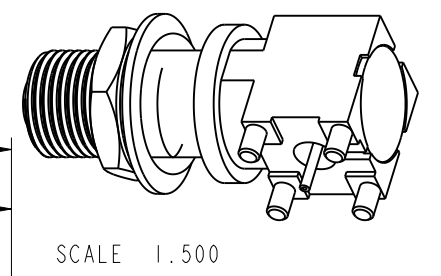
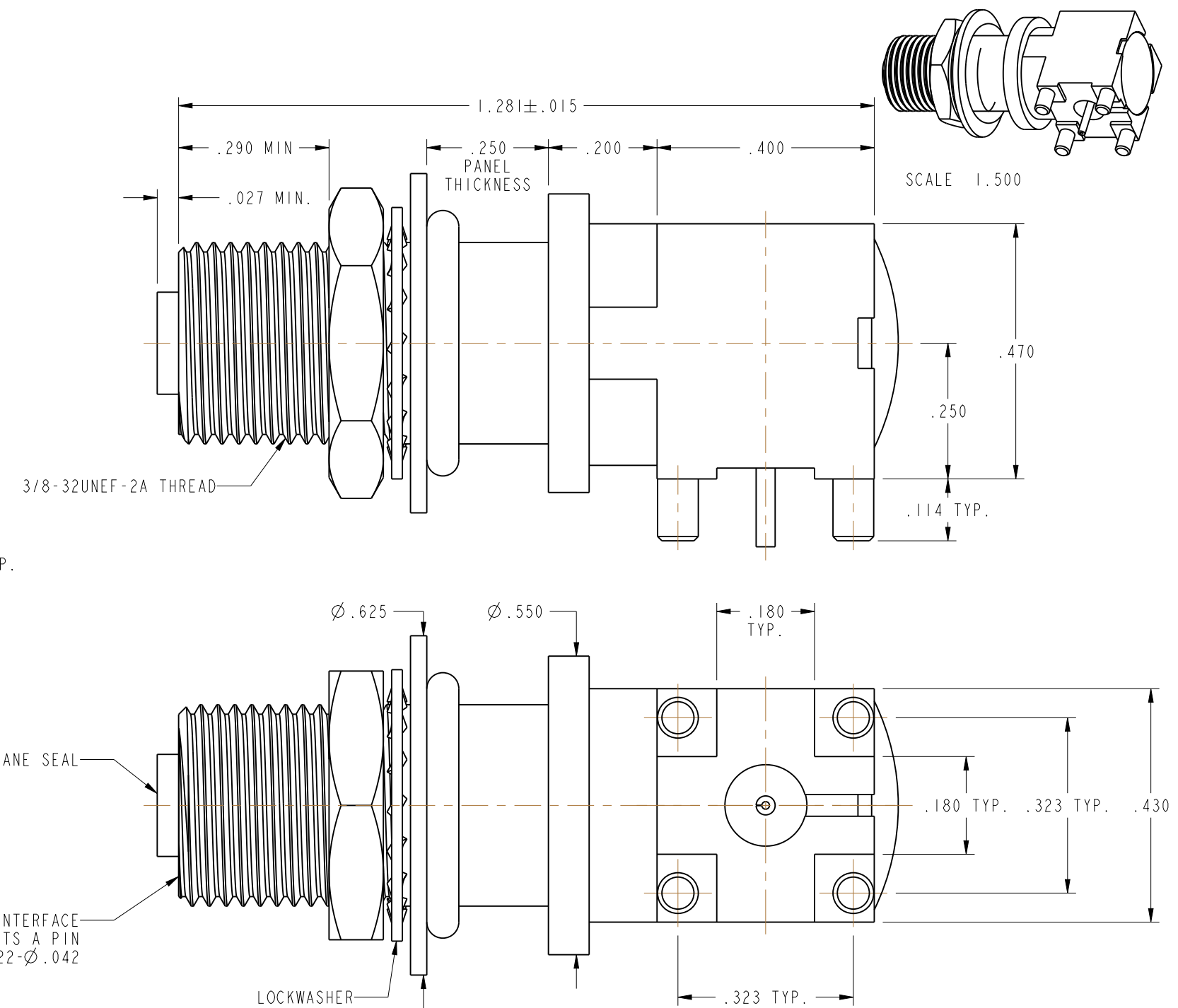
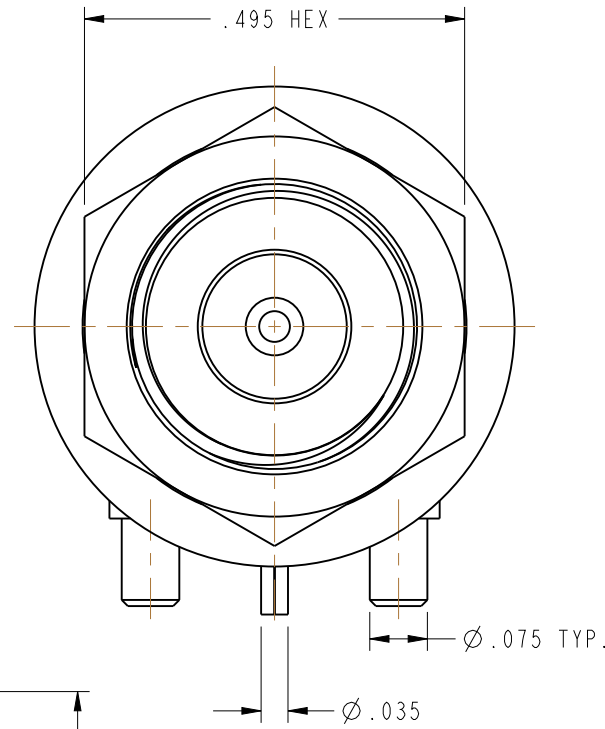

<p>UNLESS OTHERWISE SPECIFIED, DIMENSIONS ARE IN INCHES AND TOLERANCES ARE: 2 PLACE DECIMAL 3 PLACE DECIMAL ANGLES ±.015 (0,381 mm) ±.005 (0,127 mm) ± 1°</p> <p>NOTICE - These drawings, specifications, or other data (1) are, and remain the property of Amphenol corp. (2) must be returned upon request; and (3) are confidential and not to be disclosed to any person other than those to whom they are given by Amphenol Corp. the furnishing of these drawings, specifications, or other data by Amphenol Corp., or to any other person to anyone for any purpose is not to be regarded by implication or otherwise in any manner licensing, granting rights to permitting such holder or any other person to manufacture, use or sell any product, process or design, patented or otherwise, that may in any way be related to or disclosed by said drawings, specifications, or other data.</p>	MATERIAL	DRAWN	DATE	TITLE	Amphenol RF www.amphenolrf.com
	SEE NOTES	D.DAVE	22-Mar-13		
	REFERENCE	ENGINEER	DATE	SCALE: 4.0:1.0 SHEET 2 OF 2	DRAWING NO. 531-40165
	968 AND 616X-1107-100	B.C. GLEISSNER	23-Apr-03	DWG SIZE B REV B	ITEM NO. 531-40165
CONFIGURATION LEVEL:	APPROVED	DATE		PART NO. 531-40165	
FINISH	K. CAPOZZI	4/16/13			