

Voltage Supervisory Circuits with Watchdog Timer and Manual Reset Input

UM823/824/825 SOT23-5/SOT353

General Description

The UM823/824/825 series are cost effective system power supply supervisory circuits designed to monitor the power supplies in digital systems. This family provides circuit initialization and timing supervision. Independent watchdog monitoring circuitry and manual reset input are included. They significantly improve system reliability and accuracy compared to separate ICs or discrete components.

The UM823/824/825 are specifically designed to ignore fast transients on V_{CC} . Seven preprogrammed reset threshold voltages are available. All three devices have an active-low reset output, which is guaranteed to be in the correct state for V_{CC} down to 1V. The UM823 also offers a watchdog input and manual reset input. The UM824 offers a watchdog input and a complementary active-high reset. The UM825 offers a manual reset input and a complementary active-high reset.

Applications

- Applications Using DSPs, Microcontrollers or Microprocessors
- Programmable Controls
- Computers
- Embedded Systems
- Industrial Equipments
- Intelligent Instruments
- Wireless Communications Systems

Features

- Wide Operation Voltage Range of 1V to 7V
- Correct Logic Output Guaranteed to $V_{CC}=1.0V$
- Precision Supply-Voltage Monitor: 2.19V, 2.63V, 2.93V, 3.08V, 4.38V, 4.63V
- 200ms Reset Pulse Width
- Independent Watchdog Timer-1.6s Timeout
- Operating Current: 4 μ A for L/M, 3 μ A for T/S/R/Z/Y
- Temperature Range: -40°C to +85°C
- Power-Supply Transient Immunity
- SOT23-5 and SOT353 packages

Selection Guide

Function	UM823	UM824	UM825
Active-Low Reset	✓	✓	✓
Active-High Reset	-	✓	✓
Watchdog Input	✓	✓	-
Manual Reset Input	✓	-	✓

Pin Configurations

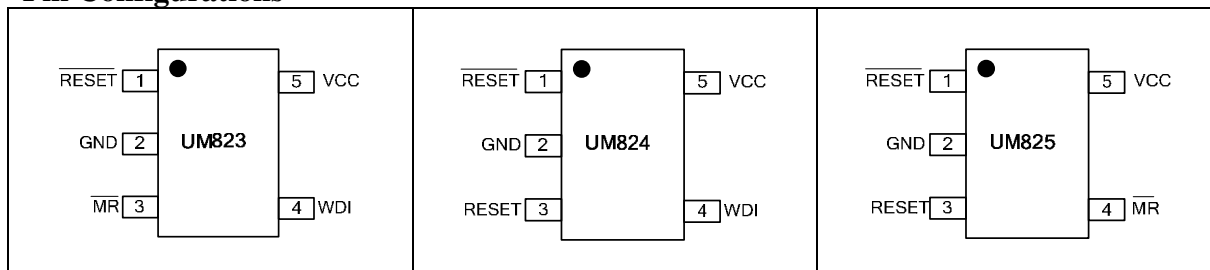

Ordering Information

UM8 XX Z P

Z: Reset Threshold (V)

=L 4.63

=M 4.38

=T 3.08

=S 2.93

=R 2.63

=Z 2.32

=Y 2.19

P: Package Type

=S SOT23-5

=P SOT353

Typical Operating Circuit

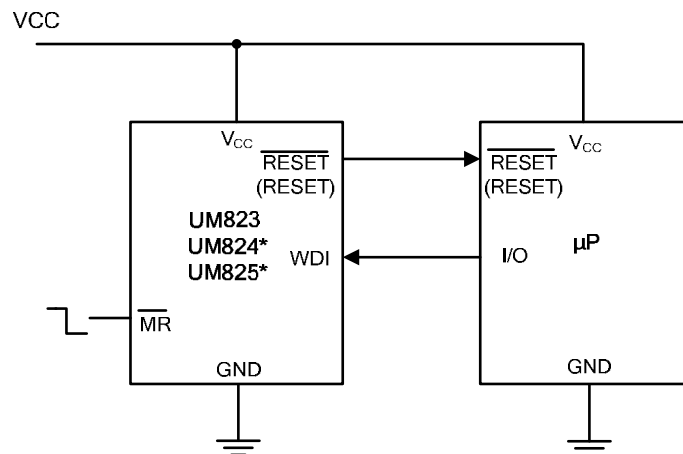

UM824 has no MR and UM825 has no WDI

Functional Diagram

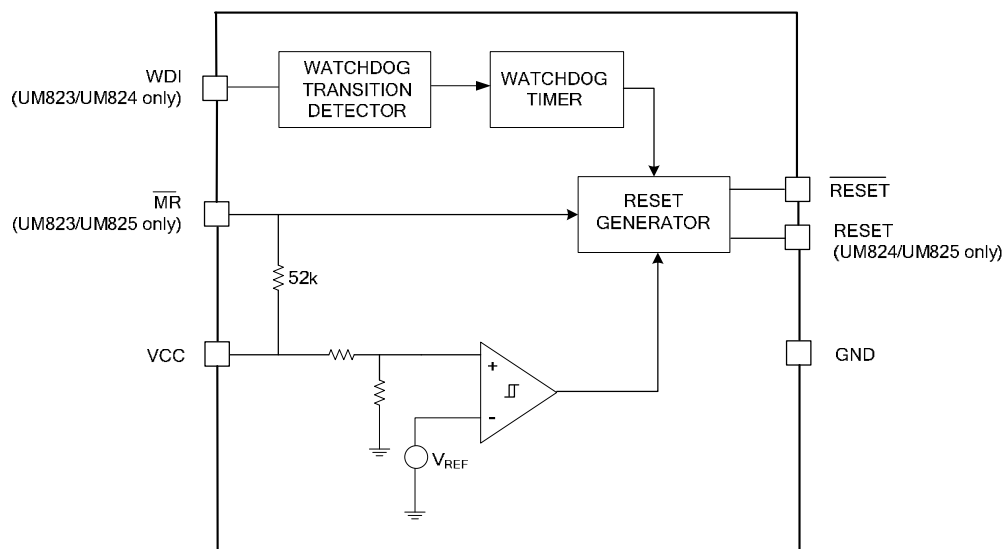

Pin Description

Pin Name	Function
GND	Ground Reference for all signals.
$\overline{\text{RESET}}$	Active-Low Reset Output. Pulses low for 200ms when triggered, and remains low whenever V_{CC} is below the reset threshold or when $\overline{\text{MR}}$ is a logic low. It remains low for 200ms after one of the following occurs: V_{CC} rises above the reset threshold, the watchdog triggers a reset, or $\overline{\text{MR}}$ goes low to high.
RESET	Active-High Reset Output. Inverse of $\overline{\text{RESET}}$.
$\overline{\text{MR}}$	Manual-Reset Input triggers a reset pulse when pulled below $0.3V_{CC}$. The active-low input has an internal $52k\Omega$ pull-up resistor. It can be driven from a TTL or CMOS logic line as well as shorted to ground with a switch. Leave open or connect to V_{CC} if unused.
WDI	Watchdog Input. If WDI remains either high or low for longer than the watchdog timeout period, the internal watchdog timer runs out and a reset is triggered. The internal watchdog timer clears whenever reset is asserted, or whenever WDI sees a rising or falling edge. If WDI is left unconnected or is connected to a three-stated buffer output, the watchdog feature is disabled.
V_{CC}	Supply Voltage

Absolute Maximum Ratings (Note 1)

Symbol	Parameter	Value	Unit	
V_{CC}	Supply Voltage	-0.3 to +8.0	V	
	RESET, $\overline{\text{RESET}}$, $\overline{\text{MR}}$, WDI	-0.3 to ($V_{CC}+0.3$)		
I_{CC}	Input Current, V_{CC} , $\overline{\text{MR}}$, WDI	20	mA	
I_O	Output Current, RESET, $\overline{\text{RESET}}$	20	mA	
P_D	Continuous Power Dissipation	SOT23-5	300	mW
		SOT353	247	
T_A	Operating Temperature Range	-40 to +85	°C	
T_{STG}	Storage Temperature Range	-65 to +150	°C	
	Lead Temperature (Soldering, 10s)	+300	°C	

Note 1: Stresses beyond those listed under “Absolute maximum Ratings” may cause permanent damage to the device. These are stress ratings only and functional operation of the device at these or any other conditions beyond those indicated in the operational sections of the specifications are not implied. Exposure to absolute maximum rating conditions for extended periods may affect device reliability.

ESD Ratings

Symbol	ESD Mode	Value	Unit
HBM	Human Body Mode	± 2000	V
CDM	Charged Device Mode	± 500	

Electrical Characteristics

($V_{CC}=4.75V$ to $5.5V$ for L version, $V_{CC}=4.5V$ to $5.5V$ for M version, $V_{CC}=3.15V$ to $3.6V$ for T version, $V_{CC}=3.0V$ to $3.6V$ for S version, $V_{CC}=2.7V$ to $3.6V$ for R version, $V_{CC}=2.38V$ to $2.75V$ for Z version, $V_{CC}=2.25V$ to $2.75V$ for Y version, $T_A=-40^{\circ}C$ to $+85^{\circ}C$ (SOT353), $T_A=-40^{\circ}C$ to $+125^{\circ}C$ (SOT23-5), unless otherwise noted. Typical values are at $T_A=+25^{\circ}C$.) (Note 2)

Symbol	Parameter	Conditions	Min	Typ	Max	Unit			
V_{CC}	Supply Voltage Range	$T_A=0^{\circ}C$ to $+70^{\circ}C$	1.0		7	V			
		$T_A=T_{MIN}$ to T_{MAX}	1.2		7	V			
I_{CC}	Supply Current	WDI and MR unconnected	UM823L/M UM824L/M		4	6	μA		
			UM823T/S/R/Z/Y UM824T/S/R/Z/Y		3	6			
		MR unconnected	UM825L/M		4	6			
			UM825T/S/R/Z/Y		3	6			
V_{TH+}	Reset Threshold	L Version	$T_A=+25^{\circ}C$	4.56	4.63	4.70	V		
			$T_A=T_{MIN}$ to T_{MAX}	4.50		4.75			
		M Version	$T_A=+25^{\circ}C$	4.31	4.38	4.45			
			$T_A=T_{MIN}$ to T_{MAX}	4.25		4.50			
		T Version	$T_A=+25^{\circ}C$	3.04	3.08	3.11			
			$T_A=T_{MIN}$ to T_{MAX}	3.00		3.15			
		S Version	$T_A=+25^{\circ}C$	2.89	2.93	2.96			
			$T_A=T_{MIN}$ to T_{MAX}	2.85		3.00			
		R Version	$T_A=+25^{\circ}C$	2.59	2.63	2.66			
			$T_A=T_{MIN}$ to T_{MAX}	2.55		2.70			
		Z Version	$T_A=+25^{\circ}C$	2.28	2.32	2.35			
			$T_A=T_{MIN}$ to T_{MAX}	2.25		2.38			
		Y Version	$T_A=+25^{\circ}C$	2.16	2.19	2.22			
			$T_A=T_{MIN}$ to T_{MAX}	2.13		2.25			
			Reset Threshold Hysteresis	L/M		20			mV
				T/S/R/Z/Y		10			
	Reset Threshold Tempco			100		ppm/ $^{\circ}C$			
t_{RP}	Reset Timeout Period		140	200	280	ms			
	V_{CC} to RESET Delay	$V_{RST}-V_{CC}=100mV$		20		μs			

Electrical Characteristics (Continued)

($V_{CC}=4.75V$ to $5.5V$ for L version, $V_{CC}=4.5V$ to $5.5V$ for M version, $V_{CC}=3.15V$ to $3.6V$ for T version, $V_{CC}=3.0V$ to $3.6V$ for S version, $V_{CC}=2.7V$ to $3.6V$ for R version, $V_{CC}=2.38V$ to $2.75V$ for Z version, $V_{CC}=2.25V$ to $2.75V$ for Y version, $T_A=-40^{\circ}C$ to $+85^{\circ}C$ (SOT353), $T_A=-40^{\circ}C$ to $+125^{\circ}C$ (SOT23-5), unless otherwise noted. Typical values are at $T_A=+25^{\circ}C$.) (Note 2)

Symbol	Parameter	Conditions	Min	Typ	Max	Unit
V_{OH}	RESET RESET Output Voltage	$V_{CC}=V_{RST\ max}$ $I_{SOURCE}=1mA$	$0.8V_{CC}$			V
V_{OL}		$V_{CC}=V_{RST\ min}$ $I_{SINK}=4mA$			0.3	
WATCHDOG INPUT(UM823/824)						
t_{WD}	Watchdog Timeout Period		1.12	1.60	2.40	s
t_{WDI}	WDI Pulse Width	$V_{IL}<0.15V_{CC}$, $V_{IH}>0.85V_{CC}$	50			ns
V_{IL}	WDI Input Voltage (Note 4)				$0.15V_{CC}$	V
V_{IH}			$0.85V_{CC}$			
	WDI Input Current	$WDI=V_{CC}$	1		20	μA
		$WDI=GND$	-20		-1	
MANUAL RESET INPUT(UM823/825)						
V_{IL}	MR Input Voltage				$0.15V_{CC}$	V
V_{IH}			$0.85V_{CC}$			
	\overline{MR} Pulse Width		1.0			μs
	MR Noise Immunity(Pulse width with no reset)			100		ns
	\overline{MR} to Reset Delay			500		ns
	MR Pullup Resistance(internal)		35	52	75	k Ω

Note 2: Over temperature limits are guaranteed by design and not production tested.

Note 3: The \overline{RESET} short-circuit current is the maximum pullup current when \overline{RESET} is driven low by a μP bidirectional reset pin.

Note 4: WDI is internally serviced within the watchdog period if WDI is left unconnected.

Detailed Description

$\overline{\text{RESET}}$ Output

A Microprocessor's reset input starts the μP in a known state. The UM823/824/825 μP supervisory circuits assert a reset to prevent code-execution errors during power-up, power-down, and brownout conditions. $\overline{\text{RESET}}$ is guaranteed to be a logic low for VCC down to 1V. Once VCC exceeds the reset threshold, an internal timer keeps $\overline{\text{RESET}}$ low for the specified reset timeout period, after this interval, $\overline{\text{RESET}}$ returns high.

If a brownout condition occurs (VCC dips below reset threshold), $\overline{\text{RESET}}$ goes low. Each time $\overline{\text{RESET}}$ is asserted it stays low for the reset timeout period. Any time VCC goes below the reset threshold the internal timer restarts. $\overline{\text{RESET}}$ both sources and sinks current, RESET on the UM824/825 is the inverse of $\overline{\text{RESET}}$.

Manual Reset Input (UM823/825)

Many μP -based products require manual reset capability allowing the operator, a test technician, or external logic circuitry to initiate a reset. On the UM823/825, a logic low on $\overline{\text{MR}}$ asserts reset. Reset remains asserted while $\overline{\text{MR}}$ is low, and for t_{RP} (200ms nominal) after it returns high. $\overline{\text{MR}}$ has an internal $52\text{k}\Omega$ pull up resistor, so it can be left open if not used. This input can be driven with CMOS logic levels or with open-drain/collector outputs. Connect a normally open momentary switch from $\overline{\text{MR}}$ to GND to create a manual-reset function; external debounce circuitry is not required. If $\overline{\text{MR}}$ is driven from long cables or the device is used in a noisy environment, connect a $0.1\mu\text{F}$ capacitor from $\overline{\text{MR}}$ to GND to provide additional noise immunity.

Watchdog Input (UM823/824)

In the UM823/824, the watchdog circuit monitors the μP 's activity. If the μP does not toggle the watchdog input (WDI) within t_{WD} (1.6s), reset asserts. The internal 1.6s timer is cleared by either a reset pulse or by toggling WDI, which detects pulses as short as 50ns. While reset is asserted, the timer remains cleared and does not count. As soon as reset is released, the timer starts counting. Disable the watchdog function by leaving WDI unconnected or by three-stating the driver connected to WDI.

Microprocessor with Bidirectional Reset

To prevent contention for microprocessor with a bidirectional reset line, a current limiting resistor is to be inserted between the $\overline{\text{RESET}}$ output pin and the microprocessor reset pin. This limits the current to a safe level if there are conflicting output reset levels. A suitable resistor value is $4.7\text{k}\Omega$. If the reset output is required for other uses, it should be buffered as shown in the figure below.

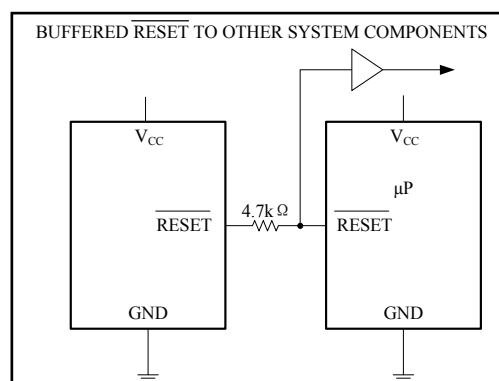

Bidirectional Reset I/O

Typical Operating Characteristics

$V_{CC}=+5V$, $T_A=25^{\circ}C$, unless otherwise noted.

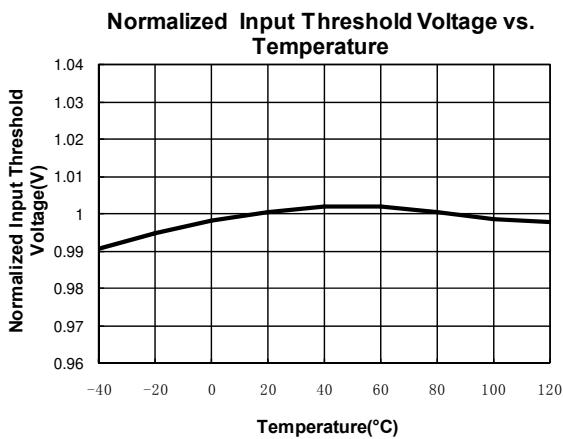
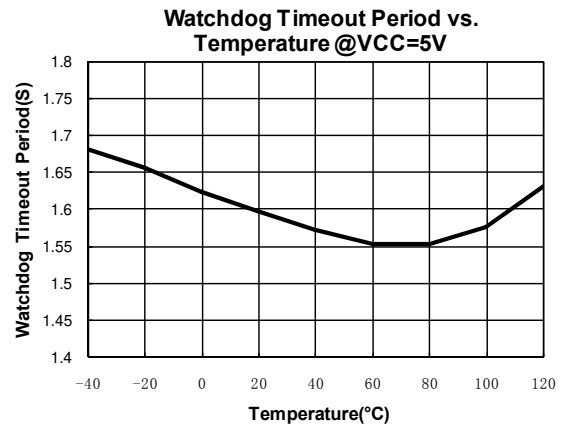
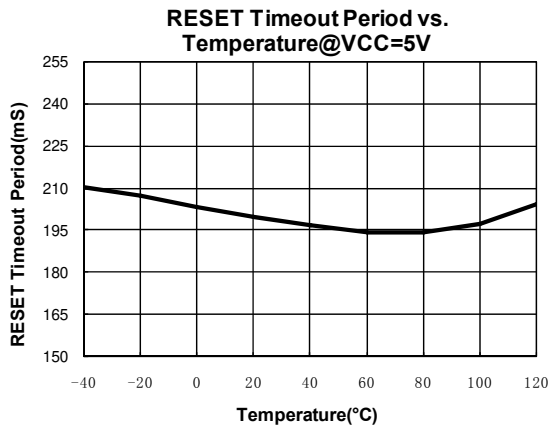
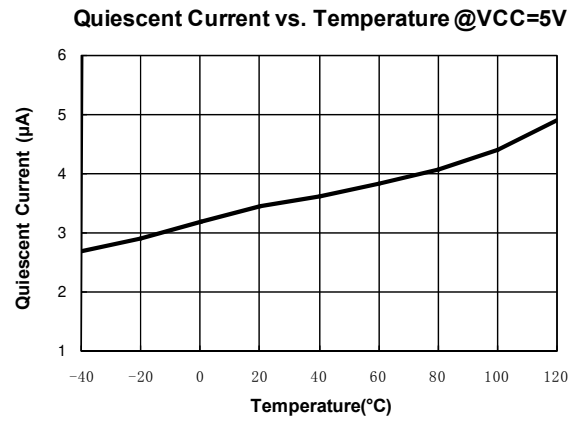
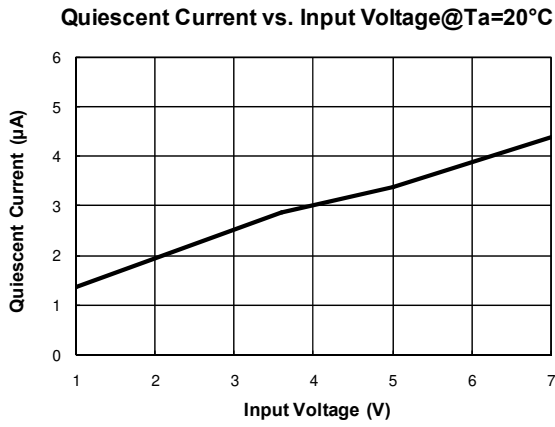

Package Information

UM823S/824S/825S SOT23-5

Outline Drawing

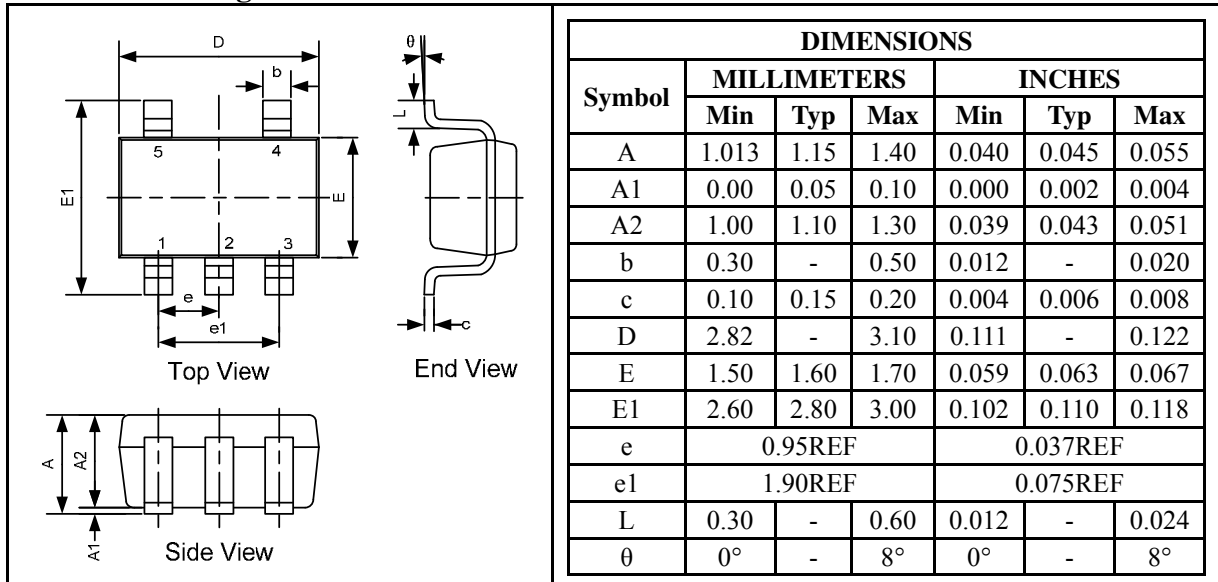

Land Pattern

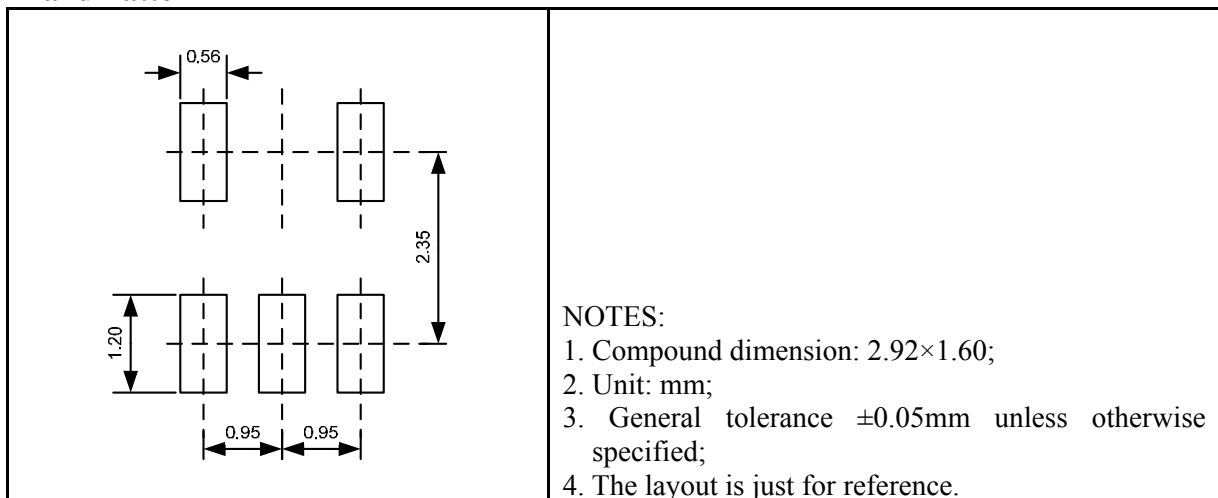

Tape and Reel Orientation



UM823P/824P/825P SOT353

Outline Drawing

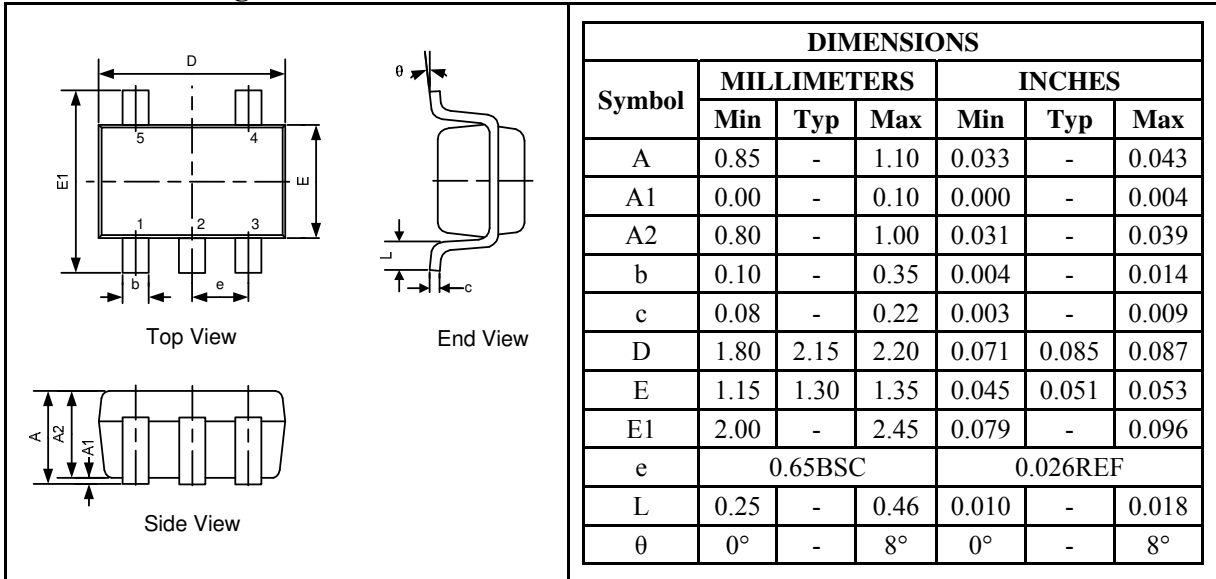

Land Pattern

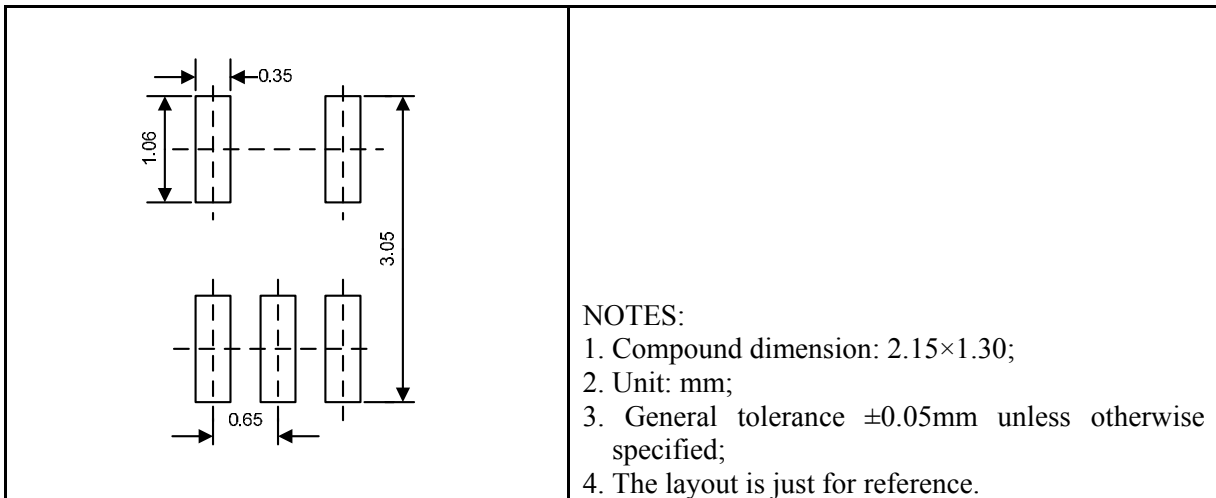

Tape and Reel Orientation

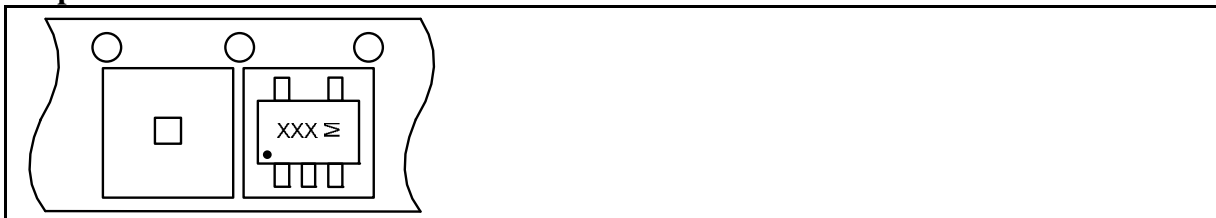

Selection Table

Part Number	RESET Threshold (V)	Top Marking	Package Type	Shipping Quantity
UM823LS	4.63	23L	SOT23-5	3000pcs/7Inch Tape Reel
UM823MS	4.38	23M		
UM823TS	3.08	23T		
UM823SS	2.93	23S		
UM823RS	2.63	23R		
UM823ZS	2.32	23Z		
UM823YS	2.19	23Y		
UM823LP	4.63	3LP	SOT353	3000pcs/7Inch Tape Reel
UM823MP	4.38	3MP		
UM823TP	3.08	3TP		
UM823SP	2.93	3SP		
UM823RP	2.63	3RP		
UM823ZP	2.32	3ZP		
UM823YP	2.19	3YP		
UM824LS	4.63	24L	SOT23-5	3000pcs/7Inch Tape Reel
UM824MS	4.38	24M		
UM824TS	3.08	24T		
UM824SS	2.93	24S		
UM824RS	2.63	24R		
UM824ZS	2.32	24Z		
UM824YS	2.19	24Y		
UM824LP	4.63	4LP	SOT353	3000pcs/7Inch Tape Reel
UM824MP	4.38	4MP		
UM824TP	3.08	4TP		
UM824SP	2.93	4SP		
UM824RP	2.63	4RP		
UM824ZP	2.32	4ZP		
UM824YP	2.19	4YP		
UM825LS	4.63	25L	SOT23-5	3000pcs/7Inch Tape Reel
UM825MS	4.38	25M		
UM825TS	3.08	25T		
UM825SS	2.93	25S		
UM825RS	2.63	25R		
UM825ZS	2.32	25Z		
UM825YS	2.19	25Y		
UM825LP	4.63	5LP	SOT353	3000pcs/7Inch Tape Reel
UM825MP	4.38	5MP		
UM825TP	3.08	5TP		
UM825SP	2.93	5SP		
UM825RP	2.63	5RP		
UM825ZP	2.32	5ZP		
UM825YP	2.19	5YP		

GREEN COMPLIANCE

Union Semiconductor is committed to environmental excellence in all aspects of its operations including meeting or exceeding regulatory requirements with respect to the use of hazardous substances. Numerous successful programs have been implemented to reduce the use of hazardous substances and/or emissions.

All Union components are compliant with the RoHS directive, which helps to support customers in their compliance with environmental directives. For more green compliance information, please visit:

http://www.union-ic.com/index.aspx?cat_code=RoHSDeclaration

IMPORTANT NOTICE

The information in this document has been carefully reviewed and is believed to be accurate. Nonetheless, this document is subject to change without notice. Union assumes no responsibility for any inaccuracies that may be contained in this document, and makes no commitment to update or to keep current the contained information, or to notify a person or organization of any update. Union reserves the right to make changes, at any time, in order to improve reliability, function or design and to attempt to supply the best product possible.



Union Semiconductor, Inc

Add: Unit 606, No.570 Shengxia Road, Shanghai 201210

Tel: 021-51093966

Fax: 021-51026018

Website: www.union-ic.com