

THIS DRAWING IS UNPUBLISHED. RELEASED FOR PUBLICATION 20
 © COPYRIGHT 20 BY TYCO ELECTRONICS CORPORATION. ALL RIGHTS RESERVED.

LOC		DIST		REVISIONS			
P	LTR	DESCRIPTION	DATE	DWN	APVD		
	A2	REVISED PER ECO-11-004109	28FEB2011	HMR	MS		

- 1. CABLE DIAMETER RANGE: $\varnothing 4.5 - \varnothing 7.9$
- 2. 36.9 IN-LBS TORQUE RECOMMENDED FOR DOME NUT.
- 3. INTERFACIAL SEAL IS SECURED TO HOUSING WITH ADHESIVE.
- 4. MOD PLUG ASSEMBLY CABLE DIAMETER RANGE 4.83 [.190] TO 5.20 [.205].
- 5. MOD PLUG ASSEMBLY CABLE DIAMETER RANGE 6.99 [.275] TO 7.87 [.310].

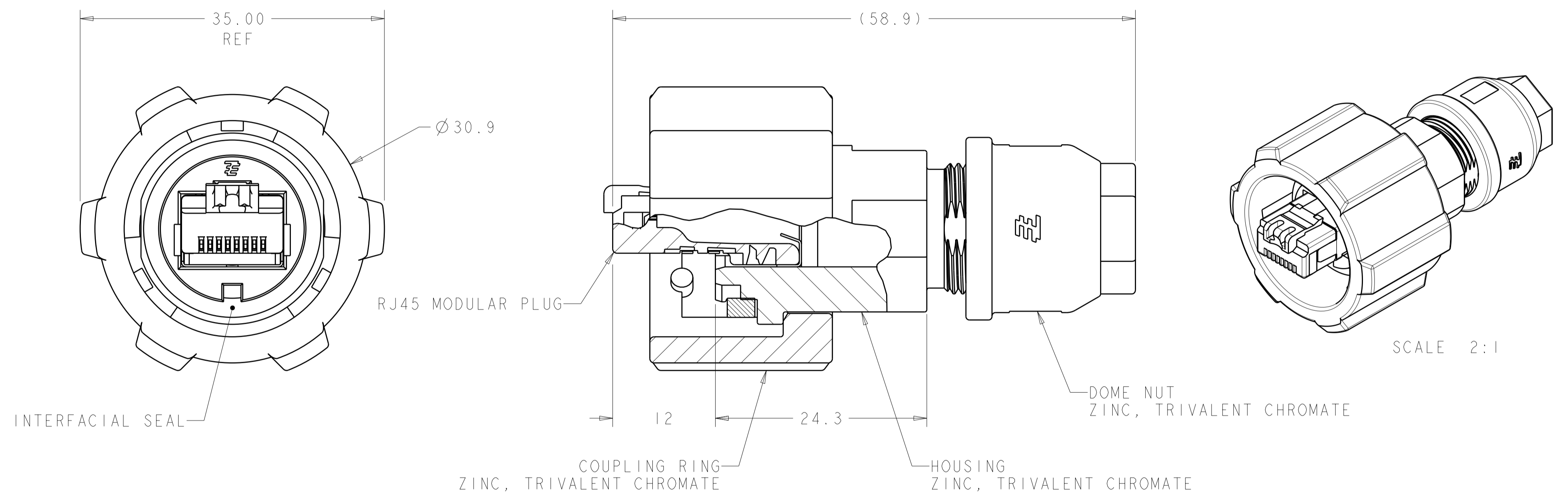

5	SOLID OR STRANDED	2008614-3
4	SOLID WIRE	2008614-2
	STRANDED WIRE	2008614-1
	WIRE TYPE	PART NUMBER

<small>THIS DRAWING IS A CONTROLLED DOCUMENT FOR TYCO ELECTRONICS CORPORATION IT IS SUBJECT TO CHANGE AND THE CONTROLLING ENGINEERING ORGANIZATION SHOULD BE CONTACTED FOR THE LATEST REVISION.</small>		DWN S. WELDON 26MAR2008 CHK C. HERTZLER 26MAR2008 APVD C. HERTZLER 26MAR2008	Tyco Electronics Tyco Electronics Harrisburg, PA 17105-3608
DIMENSIONS: mm 	TOLERANCES UNLESS OTHERWISE SPECIFIED: 0 PLC ± 1.0 1 PLC ± 0.2 2 PLC ± 0.10 3 PLC ± 0.000 4 PLC ± 0.0000 ANGLES $\pm 1^\circ$ FINISH	PRODUCT SPEC 108-2198 APPLICATION SPEC 114-13136 WEIGHT - CUSTOMER DRAWING	NAME PLUG KIT, SHIELDED, INDUSTRIAL CIRCULAR ETHERNET CONNECTOR SIZE A2 CAGE CODE 00779 DRAWING NO. C-2008614 RESTRICTED TO - SCALE 3:1 SHEET 1 OF 1 REV A2