

**NOT RECOMMENDED FOR NEW DESIGNS**

*SPLV2.8-4BTG* is eventually going to be replaced by the *SLVU2.8-4BTG* TVS Diode Array with identical form, fit, and function. Please use this device for new or future designs and more detail can be found on [Littelfuse.com](http://Littelfuse.com) Description

GREEN

## SPLV2.8-4 Series 2.8V 40A TVS Array

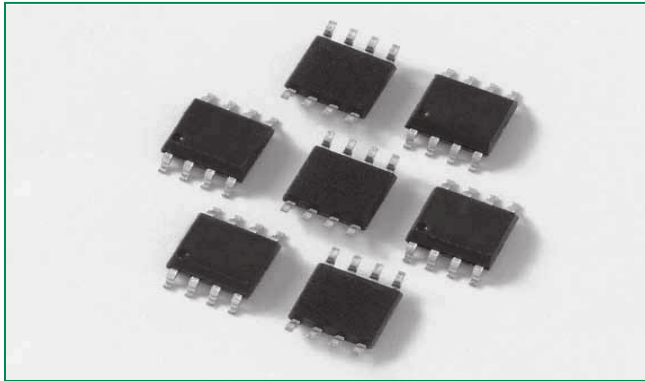

The SPLV2.8-4 was designed to protect low voltage, CMOS devices from ESD and lightning induced transients. There is a compensating diode in series with each low voltage TVS to present a low loading capacitance to the line being protected. These robust structures can safely absorb repetitive ESD strikes at  $\pm 30\text{kV}$  (contact discharge) per IEC61000-4-2 standard and each structure can safely dissipate up to 40A (IEC61000-4-5,  $t_p=8/20\mu\text{s}$ ) with very low clamping voltages.

### Pinout

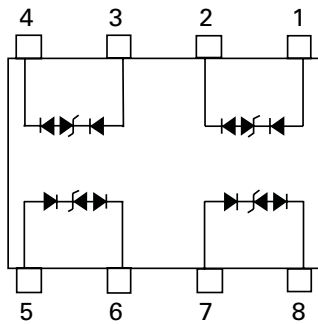

### Functional Block Diagram

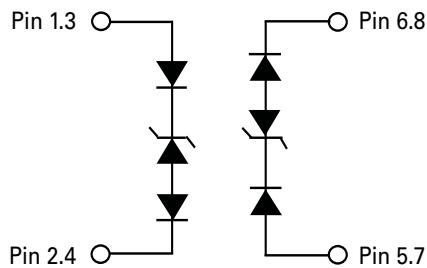

### Features

- ESD, IEC61000-4-2,  $\pm 30\text{kV}$  contact,  $\pm 30\text{kV}$  air
- EFT, IEC61000-4-4, 40A (5/50ns)
- Lightning, IEC61000-4-5, 40A (8/20 $\mu\text{s}$ )
- Low capacitance of 2pF per line
- Low leakage current of 1 $\mu\text{A}$  (MAX) at 2.8V
- SOIC-8 pin (JEDEC MS-012) configuration allows for simple flow-through layout

### Applications

- 10/100/1000 Ethernet
- WAN/LAN Equipment
- Switching Systems
- Desktops, Servers, and Notebooks
- Analog Inputs
- Base Stations

### Application Example

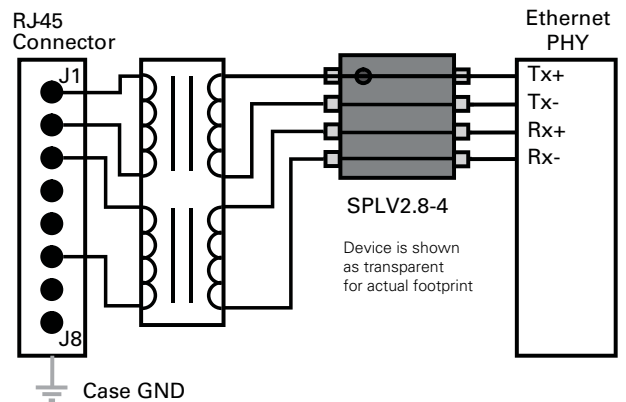

**NOT RECOMMENDED FOR NEW DESIGNS**

SPLV2.8-4BTG is eventually going to be replaced by the SLVU2.8-4BTG TVS Diode Array with identical form, fit, and function. Please use this device for new or future designs and more detail can be found on [Littelfuse.com](http://Littelfuse.com)

**Electrical Characteristics (T<sub>OP</sub> = 25°C)**

Parameter	Symbol	Test Conditions	Min	Typ	Max	Units
Reverse Standoff Voltage	V <sub>RWM</sub>	I <sub>R</sub> ≤ 1 μA			2.8	V
Reverse Breakdown Voltage	V <sub>BR</sub>	I <sub>T</sub> = 2 μA	3.0			V
Snap Back Voltage	V <sub>SB</sub>	I <sub>T</sub> = 50 mA	2.8			V
Reverse Leakage Current	I <sub>LEAK</sub>	V <sub>R</sub> = 2.8 V (Each Line)			1	μA
Clamping Voltage <sup>1</sup>	V <sub>C</sub>	I <sub>PP</sub> = 5 A, t <sub>p</sub> = 8/20 μs (Each Line)		7.0	8.5	V
Clamping Voltage <sup>1</sup>	V <sub>C</sub>	I <sub>PP</sub> = 24 A, t <sub>p</sub> = 8/20 μs (Each Line)		13.9	15.0	V
ESD Withstand Voltage <sup>1</sup>	V <sub>ESD</sub>	IEC61000-4-2 (Contact)	±30			kV
		IEC61000-4-2 (Air)	±30			kV
Dynamic Resistance	R <sub>DYN</sub>	(V <sub>C2</sub> - V <sub>C1</sub> ) / (I <sub>PP2</sub> - I <sub>PP1</sub> ) (Each Line)		0.4		Ω
Diode Capacitance <sup>1</sup>	C <sub>D</sub>	V <sub>R</sub> = 0 V, f = 1 MHz (Each Line)		2.0	2.5	pF

Note: <sup>1</sup>Parameter is guaranteed by design and/or device characterization.

**Absolute Maximum Ratings**

Parameter	Rating	Units
Peak Pulse Power (t <sub>p</sub> = 8/20 μs)	600	W
Peak Pulse Current (t <sub>p</sub> = 8/20 μs)	40	A
Operating Temperature	-40 to 85	°C
Storage Temperature	-60 to 150	°C

CAUTION: Stresses above those listed in "Absolute Maximum Ratings" may cause permanent damage to the device. This is a stress only rating and operation of the device at these or any other conditions above those indicated in the operational sections of this specification is not implied.

**Figure 1: Capacitance vs. Reverse Voltage**

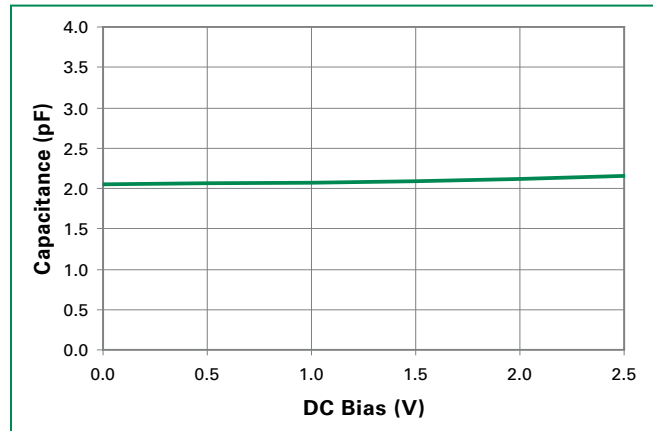

**Figure 2: Clamping Voltage vs. I<sub>PP</sub>**

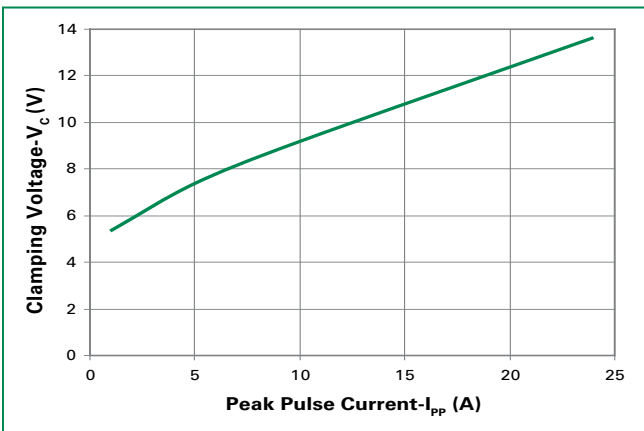

**Figure 3: Pulse Waveform**

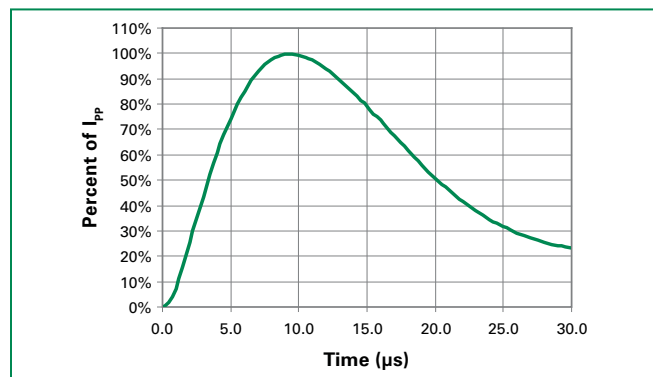

*SPLV2.8-4BTG* is eventually going to be replaced by the *SLVU2.8-4BTG* TVS Diode Array with identical form, fit, and function. Please use this device for new or future designs and more detail can be found on [Littelfuse.com](http://Littelfuse.com)

**Product Characteristics**

<b>Lead Plating</b>	Matte Tin
<b>Lead Material</b>	Copper Alloy
<b>Lead Coplanarity</b>	0.0004 inches (0.102mm)
<b>Substitute Material</b>	Silicon
<b>Body Material</b>	Molded Epoxy
<b>Flammability</b>	UL 94 V-0

- Notes :
1. All dimensions are in millimeters
  2. Dimensions include solder plating.
  3. Dimensions are exclusive of mold flash & metal burr.
  4. Blo is facing up for mold and facing down for trim/form, i.e. reverse trim/form.
  5. Package surface matte finish VDI 11-13.

**Soldering Parameters**

Reflow Condition		Pb – Free assembly
Pre Heat	- Temperature Min ( $T_{s(min)}$ )	150°C
	- Temperature Max ( $T_{s(max)}$ )	200°C
	- Time (min to max) ( $t_s$ )	60 – 180 secs
Average ramp up rate (Liquidus Temp ( $T_L$ ) to peak)		5°C/second max
$T_{s(max)}$ to $T_L$ - Ramp-up Rate		5°C/second max
Reflow	- Temperature ( $T_L$ ) (Liquidus)	217°C
	- Temperature ( $t_L$ )	60 – 150 seconds
Peak Temperature ( $T_p$ )		260 <sup>+0/-5</sup> °C
Time within 5°C of actual peak Temperature ( $t_p$ )		20 – 40 seconds
Ramp-down Rate		5°C/second max
Time 25°C to peak Temperature ( $T_p$ )		8 minutes Max.
Do not exceed		260°C

SPLV2.8-4

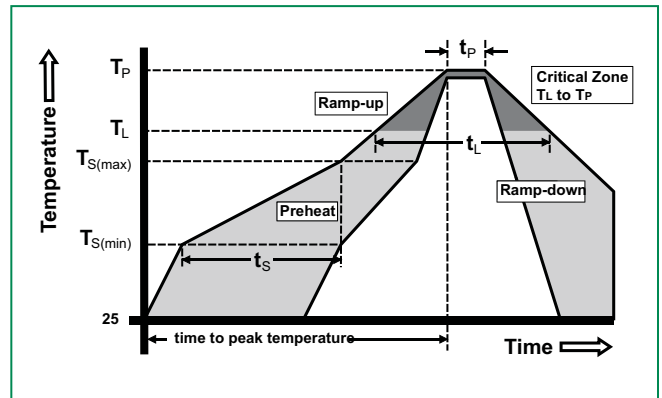

**Package Dimensions – Mechanical Drawings and Recommended Solder Pad Outline**

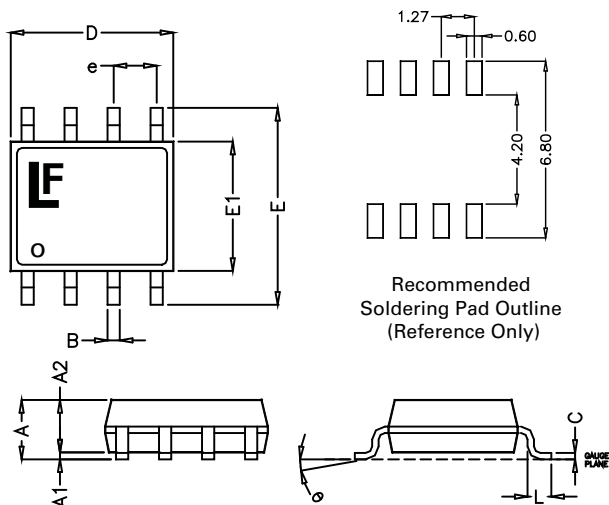

Package	SOIC			
Pins	8			
JEDEC	MS-012			
	Millimetres		Inches	
	Min	Max	Min	Max
<b>A</b>	1.35	1.75	0.053	0.069
<b>A1</b>	0.10	0.25	0.004	0.010
<b>A2</b>	1.25	1.65	0.050	0.065
<b>B</b>	0.31	0.51	0.012	0.020
<b>c</b>	0.17	0.25	0.007	0.010
<b>D</b>	4.80	5.00	0.189	0.197
<b>E</b>	5.80	6.20	0.228	0.244
<b>E1</b>	3.80	4.00	0.150	0.157
<b>e</b>	1.27 BSC		0.050 BSC	
<b>L</b>	0.40	1.27	0.016	0.050

SPLV2.8-4 Series  
**NOT RECOMMENDED FOR NEW DESIGNS**

SPLV2.8-4BTG is eventually going to be replaced by the SLVU2.8-4BTG TVS Diode Array with identical form, fit, and function. Please use this device for new or future designs and more detail can be found on [Littelfuse.com](http://Littelfuse.com)

**Part Numbering System**

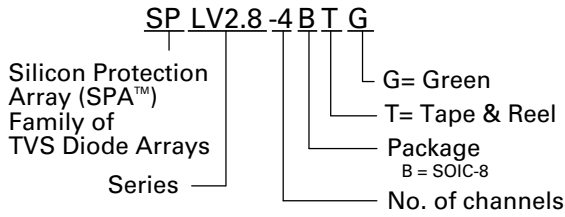

**Part Marking System**

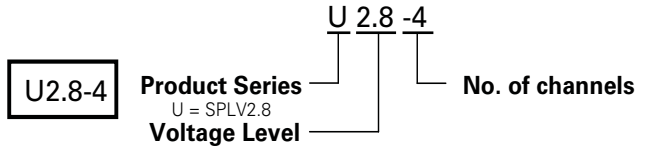

**Ordering Information**

Part Number	Package	Marking	Min. Order Qty.
SPLV2.8-4BTG	SOIC-8	U2.8-4	2500

**Embossed Carrier Tape & Reel Specification – SOIC Package**

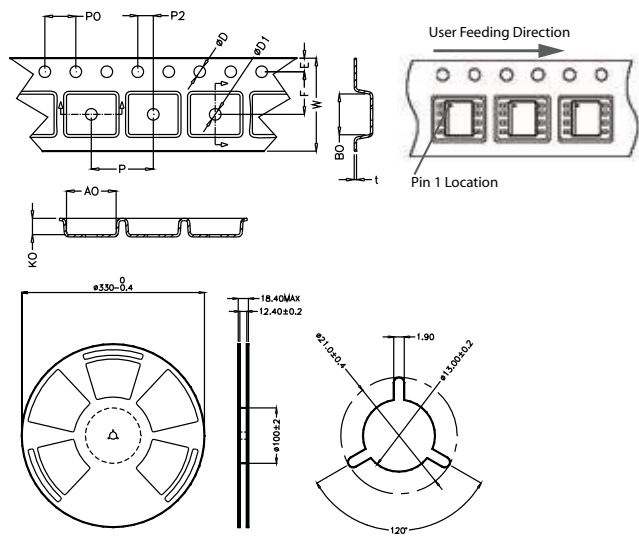

Symbol	Millimetres		Inches	
	Min	Max	Min	Max
E	1.65	1.85	0.065	0.073
F	5.4	5.6	0.213	0.22
P2	1.95	2.05	0.077	0.081
D	1.5	1.6	0.059	0.063
D1	1.50 Min		0.059 Min	
P0	3.9	4.1	0.154	0.161
10P0	40.0 +/- 0.20		1.574 +/- 0.008	
W	11.9	12.1	0.468	0.476
P	7.9	8.1	0.311	0.319
A0	6.3	6.5	0.248	0.256
B0	5.1	5.3	0.2	0.209
K0	2	2.2	0.079	0.087
t	0.30 +/- 0.05		0.012 +/- 0.002	