

# SMT Power Inductors

Power Beads - PA4792.XXXHL, PA4793.XXXHL & PA5121 Series



- Ⓢ **Current Rating:** PA4792 (100Apk), PA4793 (60Apk)
- Ⓢ **Inductance Range:** 200nH to 500nH
- Ⓢ **Height:** 7.25mm Max (PA4792)  
6.6mm Max (PA4793)  
5.35mm Max (PA5121)
- Ⓢ **Footprint:** 22.2mm x 8.2mm Max (PA4792)  
15.1mm x 8.6mm Max (PA4793)  
8.3mm x 7.5mm Max (PA5121)

## Electrical Specifications @ 25°C – Operating Temperature -40°C to +130°C<sup>7</sup>

Part Number	Inductance <sup>1</sup> @ 0Adc (nH ±10%)	Inductance <sup>2</sup> @Irated (nH TYP)	Irated <sup>3</sup> (ADC)	DCR <sup>4</sup> (mΩ)	Saturation Current <sup>5</sup> (A TYP)		Heating Current <sup>6</sup> (A TYP)	Hi-pot <sup>10</sup> (Vdc)
					25°C	100°C		
<b>PA4792.XXXHL: 22.2 x 8.2 x 7.25mm Max</b>								
PA4792.231HLT	230	230	46	0.47±10%	100	86	46	200
<b>PA4793.XXXHL: 15.1 x 8.6 x 6.6mm Max</b>								
PA4793.501HLT	500	470	40	1.15±15%	60	51	40	200
<b>PA5121.XXXHL: 8.3 x 7.5 x 5.35mm Max</b>								
PA5121.201HLT	200	200	13	0.65 +/-0.15	25	21	13	200
PA5121.231HLT	230	230	13	0.65 +/-0.15	23	19.5	13	200

### NOTES:

1. Inductance measured at 100kHz, 100mVrms. For PA4793 the listed inductance is measured from 1-3 with pins 2,4 shorted
2. Inductance at Irated is the value of the inductance at 25°C at the listed rated current.
3. The rated current as listed is either the saturation current (25°C or 100°C) or the heating current depending on which value is lower.
4. The nominal DCR is measured from point ① to point ②, as shown below on the mechanical drawing. For PA4793 the listed DCR value is for each winding.
5. The saturation current is the typical current which causes the inductance to drop by 20% (for PA4792 and PA4793) or 2% (for PA5121) at the stated ambient temperatures (25°C, 100°C). This current is determined by placing the component in the specified ambient environment and applying a short duration pulse current (to eliminate self-heating effects) to the component.
6. The heating current is the DC current which causes the part temperature to increase by approximately 40°C when used in a typical application.
7. In high volt\*time applications, additional heating in the component can occur due to core losses in the inductor which may necessitate derating the current in order to limit the temperature rise of the component. To determine the approximate total losses (or temperature rise) for a given application, the coreloss and temperature rise curves can be used.
8. Parts with the HLT suffix are sold in tape and reel packaging. Pulse complies to industry standard tape and reel specification EIA-481. Samples of these parts can be ordered by removing the HLT suffix and replacing with HL.
9. The temperature of the component (ambient plus temperature rise) must be within the stated operating temperature range.
10. Hi-pot is measured from the bottom of the core to the leads. Hi-pot is tested for 2sec with a leakage current maximum of 0.1mA.

# SMT Power Inductors

Power Beads - PA4792.XXXHL, PA4793.XXXHL & PA5121 Series



## Mechanical

## Schematic

### PA4792.XXXHL

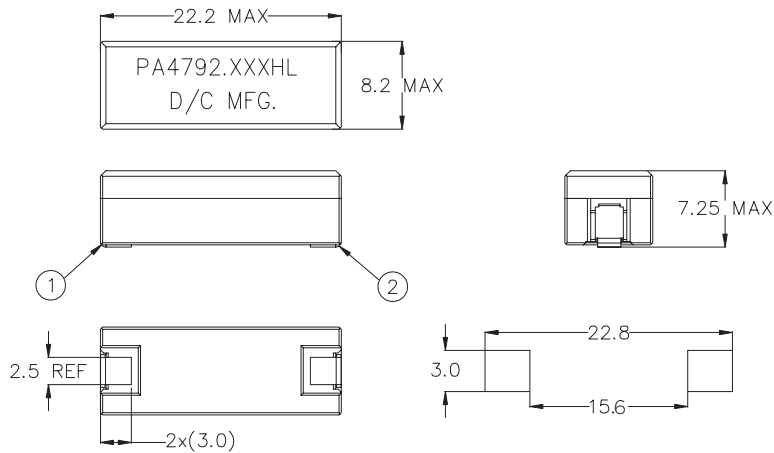

FINAL OUTLINE

RECOMMENDED PAD LAYOUT

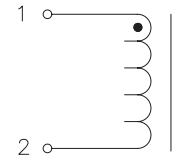

**Weight** .....5.20grams  
**Tape & Reel** .....500/reel

**Dimensions: mm**  
 Unless otherwise specified,  
 all tolerances are  $\pm 0.25$

## Mechanical

## Schematic

### PA4793.XXXHL

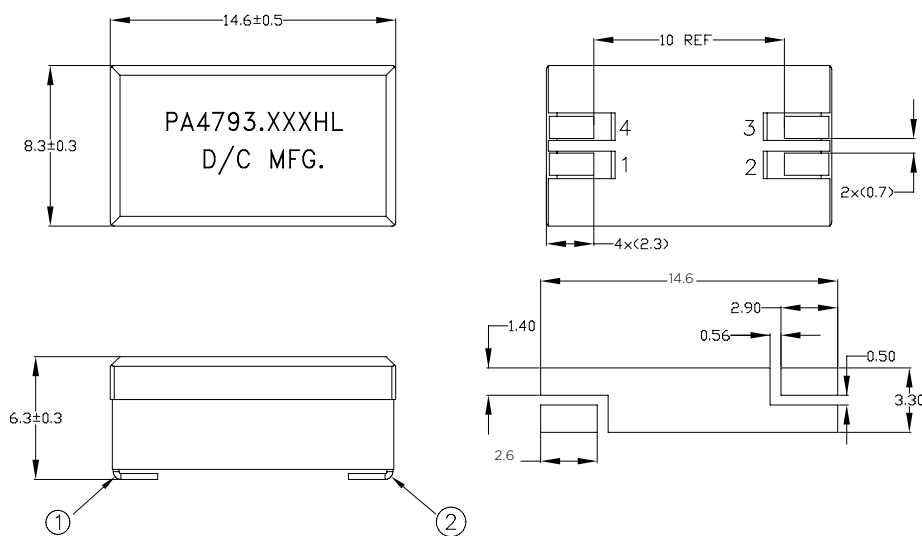

FINAL OUTLINE

RECOMMENDED PAD LAYOUT

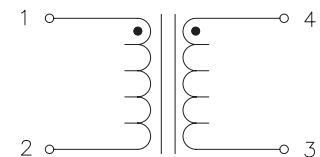

**Weight** .....3.39grams  
**Tape & Reel** .....500/reel

**Dimensions: mm**  
 Unless otherwise specified,  
 all tolerances are  $\pm 0.25$

# SMT Power Inductors

Power Beads - PA4792.XXXHL, PA4793.XXXHL & PA5121 Series



## Mechanical

## Schematic

### PA5121.XXXHLT

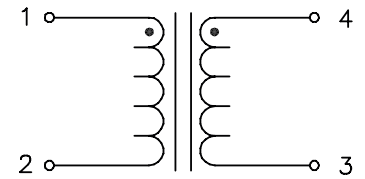
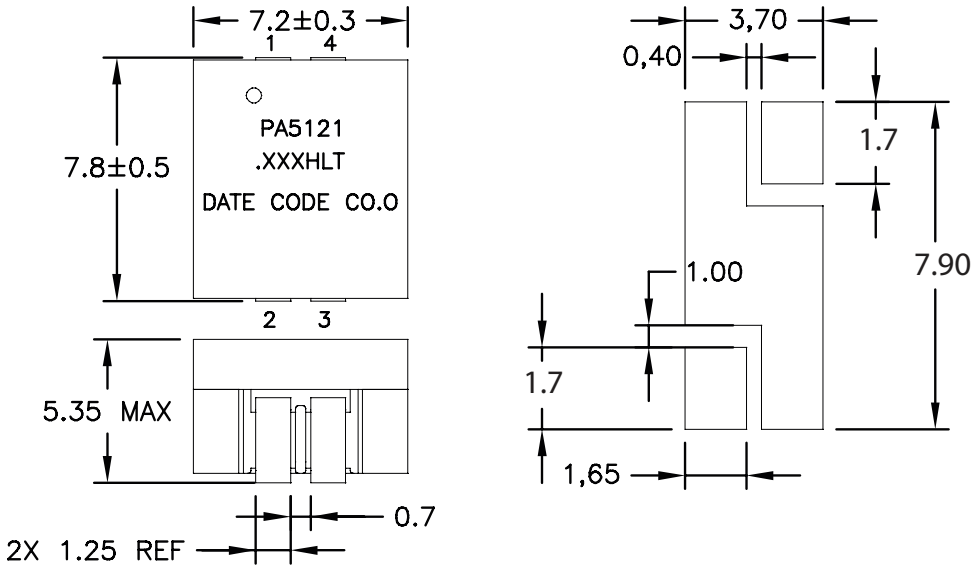

**Weight** .....2.8grams  
**Tape & Reel** .....800/reel

**Dimensions: mm**  
Unless otherwise specified,  
all tolerances are  $\pm 0.25$

## PA4792.231HL, LvsI, 25 °C/100 °C

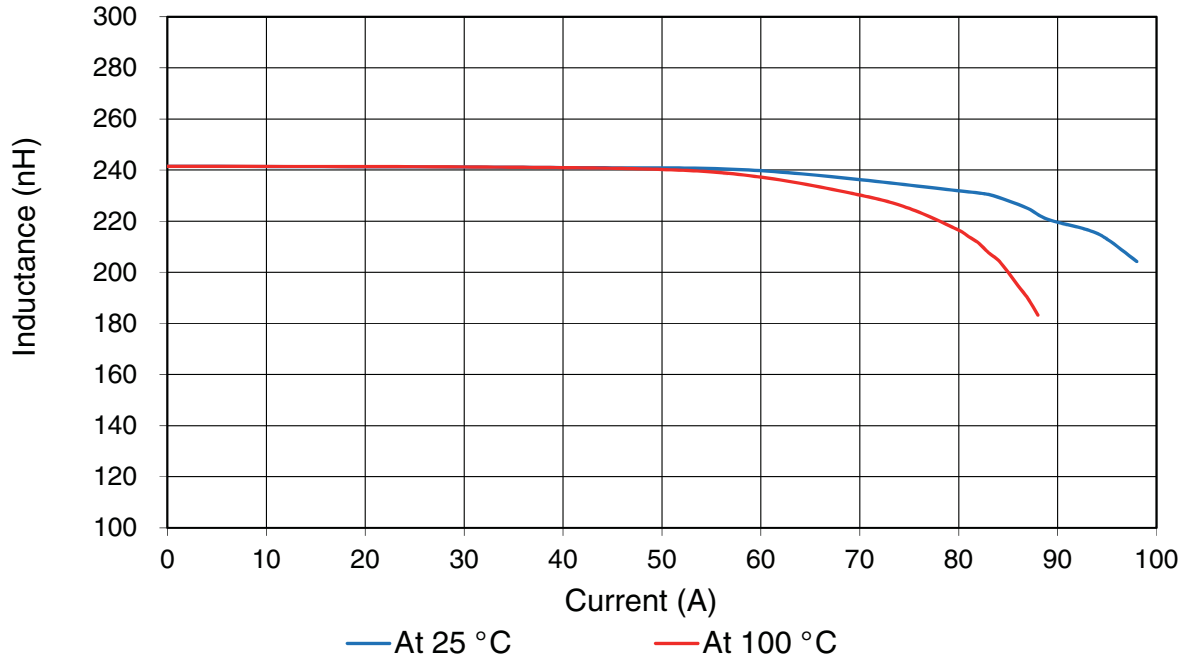

## PA4793.501HL, LvsI, 25 °C/100 °C

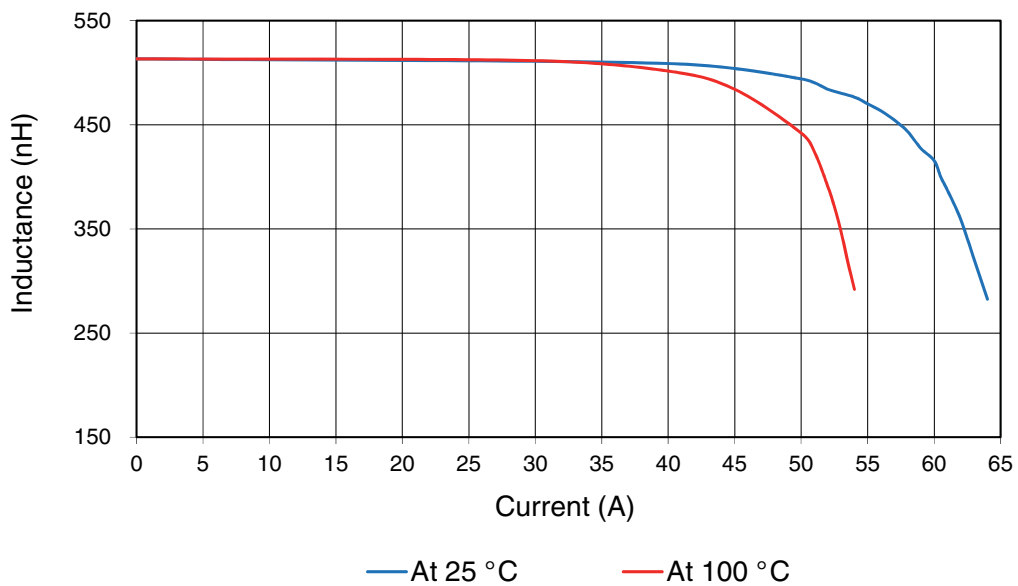

### PA5121.201HLT, LvsI, 25C and 100C

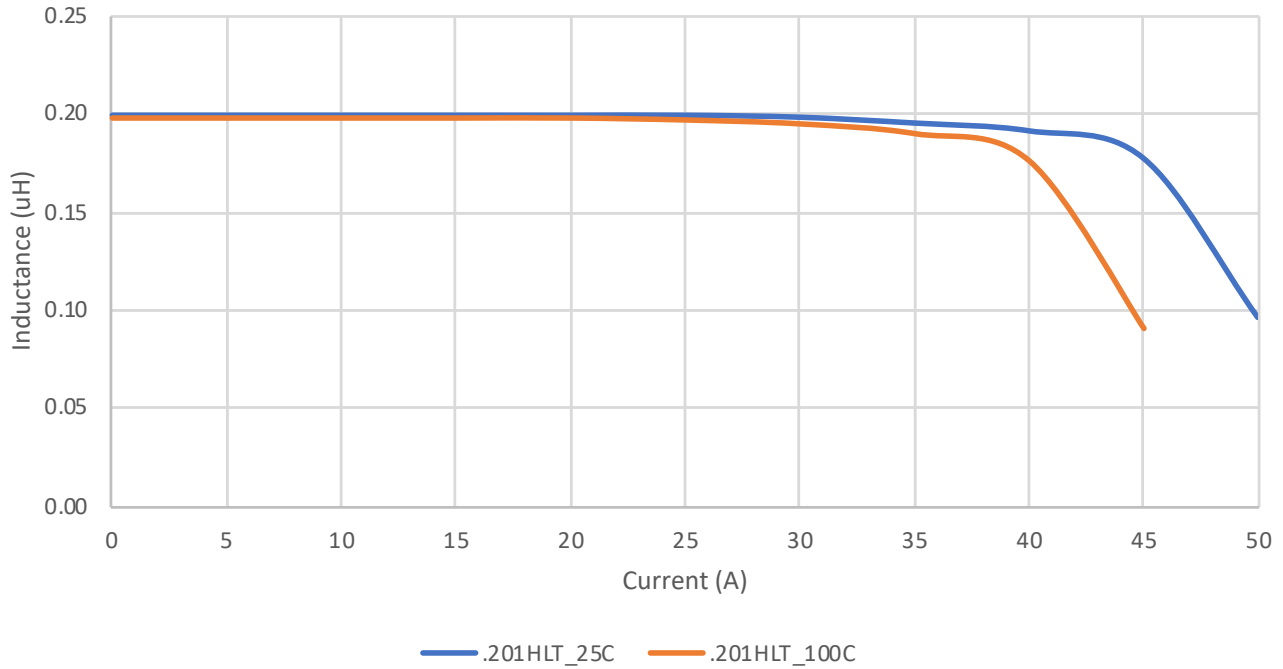

### PA5121.231HL L vs I curve

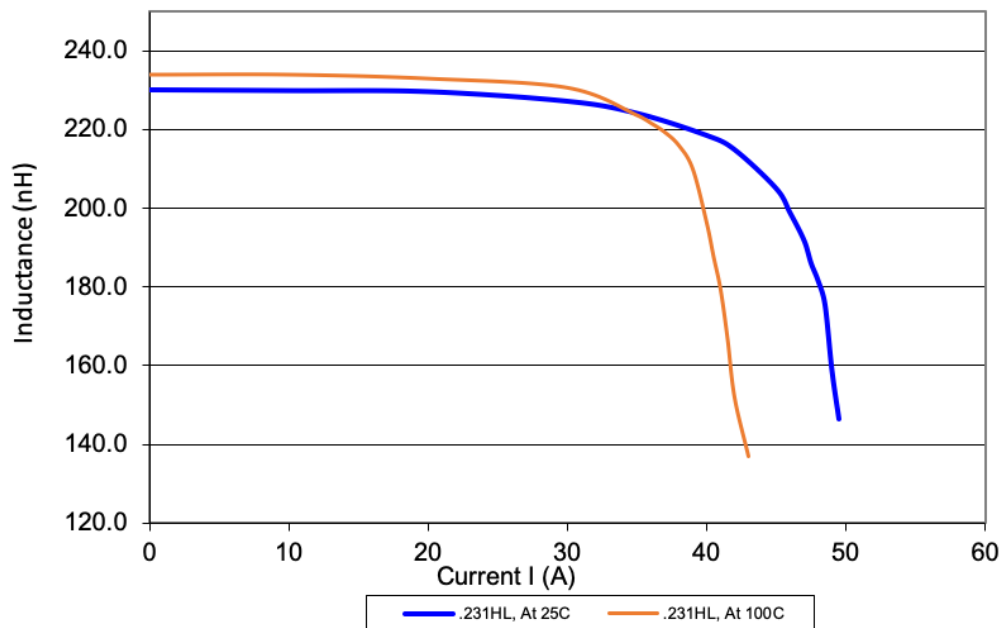

# SMT Power Inductors

Power Beads - PA4792.XXXHL, PA4793.XXXHL & PA5121 Series

## TAPE & REEL INFO

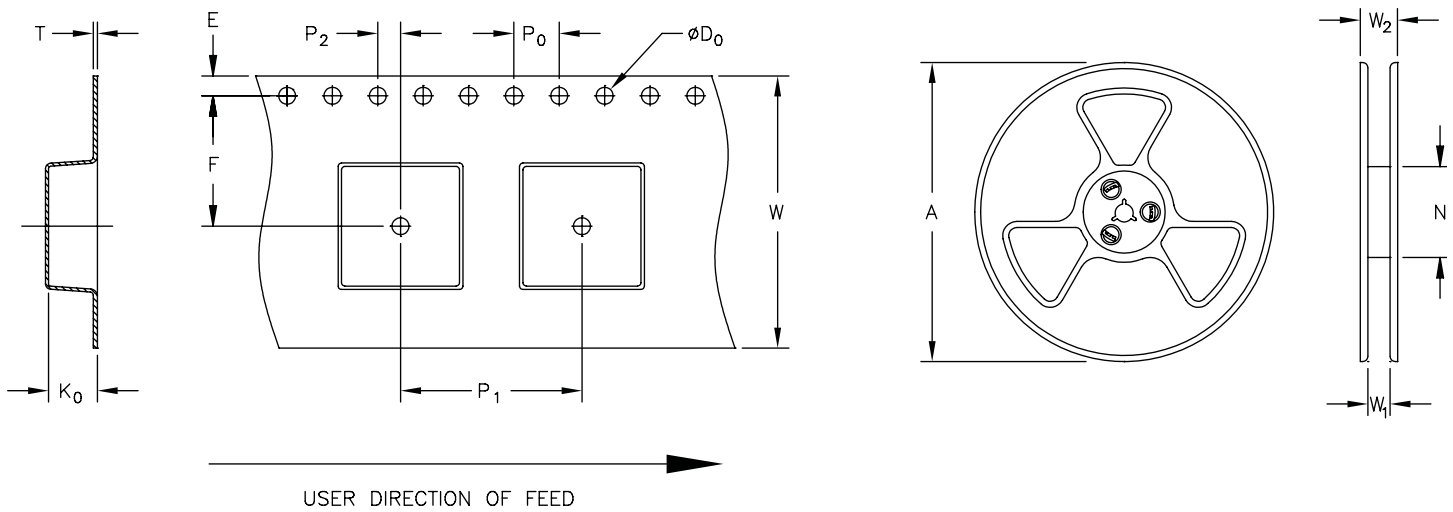

## SURFACE MOUNTING TYPE, REEL/TAPE LIST

TYPE	REEL SIZE (mm)				TAPE SIZE (mm)									QTY PCS/REEL
	A	W <sub>1</sub>	W <sub>2</sub>	N	E	F	D <sub>0</sub>	P <sub>0</sub>	P <sub>1</sub>	P <sub>2</sub>	W	T	K <sub>0</sub>	
PA4792.XXXHLT	Ø330	44.4	50.4	100	1.75	20.2	1.5	4	16	2	44	0.5	7.9	500
PA4793.XXXHLT	Ø330	32.4	38.4	100	1.75	14.2	1.5	4	16	2	32	0.5	7	500
PA5121.XXXHLT	Ø330	16.4	32.4	100	1.75	7.5	1.5	4.0	12	2	16	0.4	5.6	800

## For More Information:

Americas - [prodinfo\\_power@pulseelectronics.com](mailto:prodinfo_power@pulseelectronics.com) | Europe - [power-apps-europe@pulseelectronics.com](mailto:power-apps-europe@pulseelectronics.com) | Asia - [power-apps-asia@pulseelectronics.com](mailto:power-apps-asia@pulseelectronics.com)

Performance warranty of products offered on this data sheet is limited to the parameters specified. Data is subject to change without notice. Other brand and product names mentioned herein may be trademarks or registered trademarks of their respective owners. © Copyright, 2020. Pulse Electronics, Inc. All rights reserved.