

2 Screws for sizes 9&15, 3 for other sizes

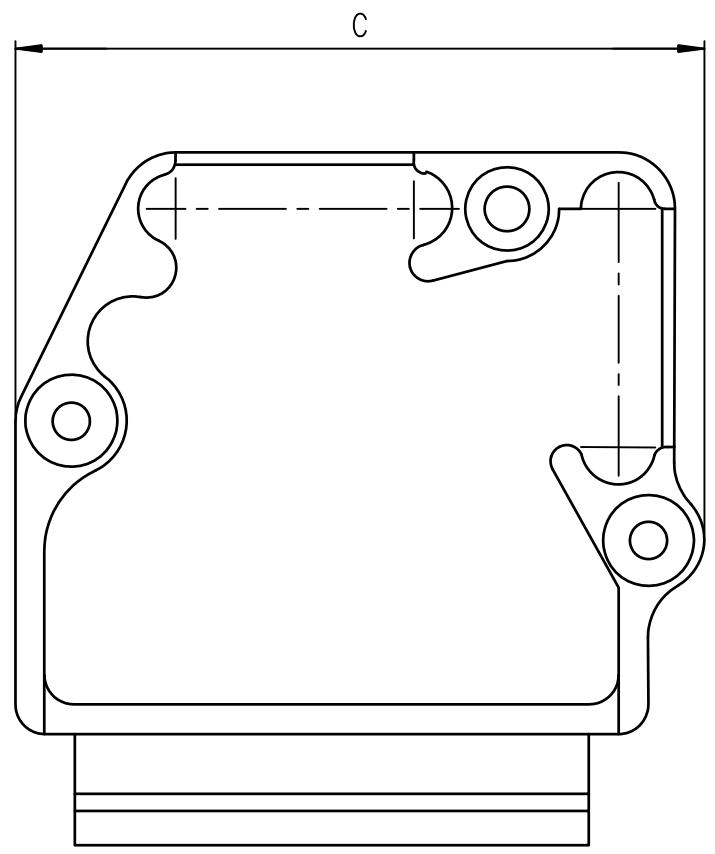
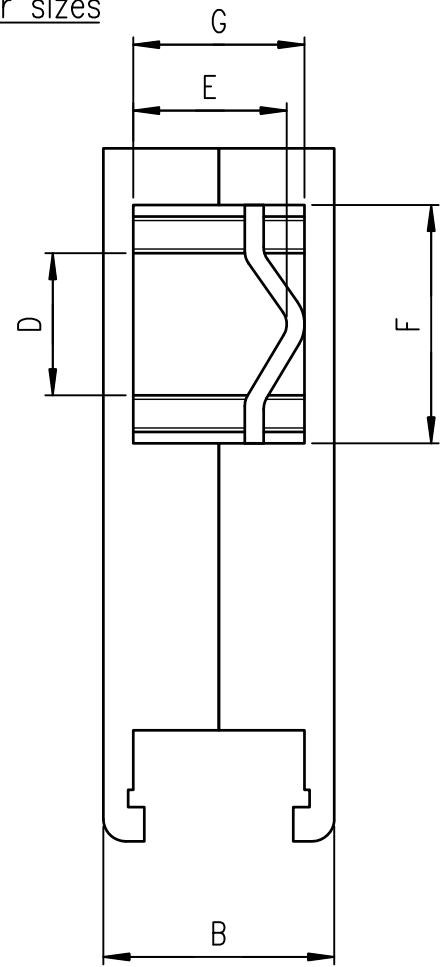
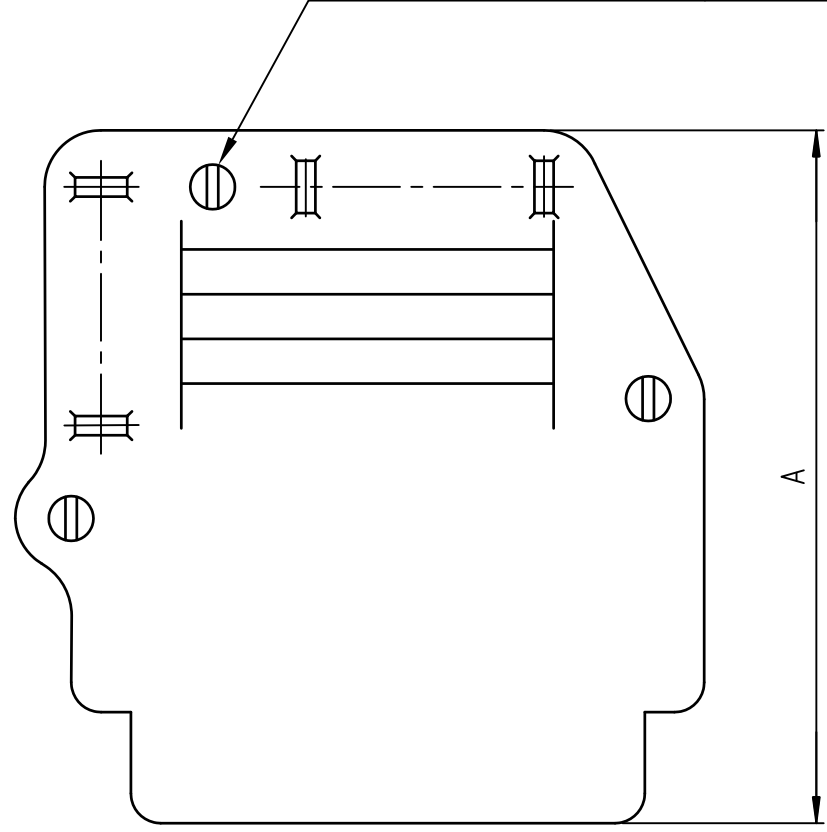

MATERIAL:
Metalized thermoplastic

TEMPERATURE RANGE:
- Climatic category
 metallised hood 55°/ +125°
 black hood 55°/ +95°

PACKAGING:
Box of 50 individual sets



FCIconnect.com

Tie-Wrap

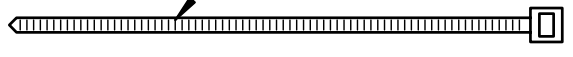

CLAMP FOR SIZES 25, 37 & 50

CLAMP FOR SIZES 9 & 15

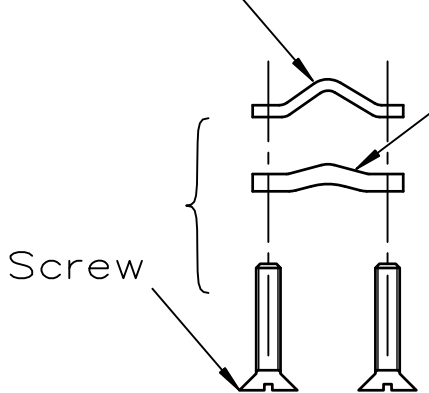

Bill of material		
components	Hood kit	Kit for 2 exit use
1/2 Hood	2	0
Screw	2	2
Tapping Screw	3	0
Tie Wrap	1	1
Clamp	1	1

Shell size	Number of contacts	A±0.3	B±0.3	C±0.3	With clamp		Without clamp		PART NUMBER		
					D±0.2	E		F±0.5	G±0.5	Metalized hood	Kit for 2 exit use *
						mini	maxi				
E	09	29.80	15.50	24.25	6.00	0.25	10.30	8.00	11.70	863093C09MLF	863093CEALF
A	15	29.80	15.50	32.50	6.00	0.25	10.30	8.00	11.70	863093C15MLF	
B	25	46.80	15.50	46.00	13.90	2.30	10.30	16.20	11.70	863093C25MLF	863093CBCLF
C	37	46.80	15.50	60.50	13.90	2.30	10.30	16.20	11.70	863093C37MLF	
D	50	48.80	18.00	56.50	15.60	3.90	12.60	18.00	14.00	863093C50MLF	863093CDLF

Dimensions are in millimeters

* additional accessories to be ordered separately

NOTE: RoHS INFORMATIONS

- The "LF" product meets European union Directives and other country regulations as described in GS-47-0004.
- The product is not intended to be exposed to a manufacturing solder process.
- Packaging spec: see GS-14-920.

mat'l. code				surface <input checked="" type="checkbox"/> ISO 1302 <input checked="" type="checkbox"/> ISO 406 <input type="checkbox"/> ISO 1101		tolerance		projection		product family	
-				tolerances unless otherwise specified		MM		D-SUB		-	
title				angles		linear		scale 2		UNIVERSAL PLASTIC HOOD	
-				±2'		.XX±0.1		.XXX±0.05		-	
ltr		ecn no		dr		date		MITHUN PAUL		2013/06/27	
H		ELX-I-15253		MP		2013/07/16		MITHUN PAUL		2013/06/27	
-		-		-		-		MITHUN PAUL		2013/07/16	
C		LS07-0300		MPE		2007/11/21		BIJU K PAUL		2013/07/16	
D		LS07-0319		MPE		2007/12/18		MITHUN PAUL		2013/06/27	
E		LS07-0321		MPE		2007/12/19		MITHUN PAUL		2013/06/27	
F		I11-0091		AMR		2011/05/14		MITHUN PAUL		2013/07/16	
G		ELX-I-15087		MP		2013/06/27		BIJU K PAUL		2013/07/16	
sheet index		revision sheet		H		1					



dwg no C01-8655-1620 sheet 1 of 1 size A3

type CUSTOMER Drawing

Copyright FCI