

C-Q28ARQ28JU-O3M  
ARISTA NETWORKS TO JUNIPER NETWORKS  
100GBASE-AOC QSFP28 MMF  
850NM, 3M



### C-Q28ARQ28JU-O3M

Arista Networks® to Juniper Networks® Compatible TAA Compliant 100GBase-AOC QSFP28 to QSFP28 Active Optical Cable (850nm, MMF, 3m)

#### Features

- QSFP28 MSA compliant
- Four independent full-duplex channels
- Supports 103.1Gb/s aggregate bit rate
- 3m length
- Operating case temperature: 0°C to 70°C
- 4x25G electrical interface (OIF CEI-28G-VSR)
- Single 3.3V power supply
- Maximum power consumption 2.5W each terminal
- RoHS-6 compliant



#### Applications

- 100G Ethernet
- InfiniBand EDR

#### Product Description

This Arista Networks® AOC-Q-Q-100G-3M to Juniper Networks® JNP-100GC-3M dual OEM compatible 100GBase-AOC QSFP28 to QSFP28 active optical cable has a maximum reach of 3.0m (9.8ft). It is 100% Arista Networks® to Juniper Networks® compatible and has been programmed, uniquely serialized, data-traffic and application tested to ensure that it is compliant and functional. This active optical cable will initialize and perform identically to Arista Networks® and Juniper Networks®' individual cables and is built to meet or exceed Arista Networks® and Juniper Networks®' specifications. This product complies with MSA (Multi-Source Agreement) standards and is TAA (Trade Acts Agreement) compliant. We stand behind the quality of our products and proudly offer a limited lifetime warranty.

ProLabs' QSFP28 active optical cables are RoHS compliant and lead-free.

TAA refers to the Trade Agreements Act (19 U.S.C. & 2501-2581), which is intended to foster fair and open international trade. TAA requires that the U.S. Government may acquire only "U.S. – made or designated country end products."



## AOC Block Diagram

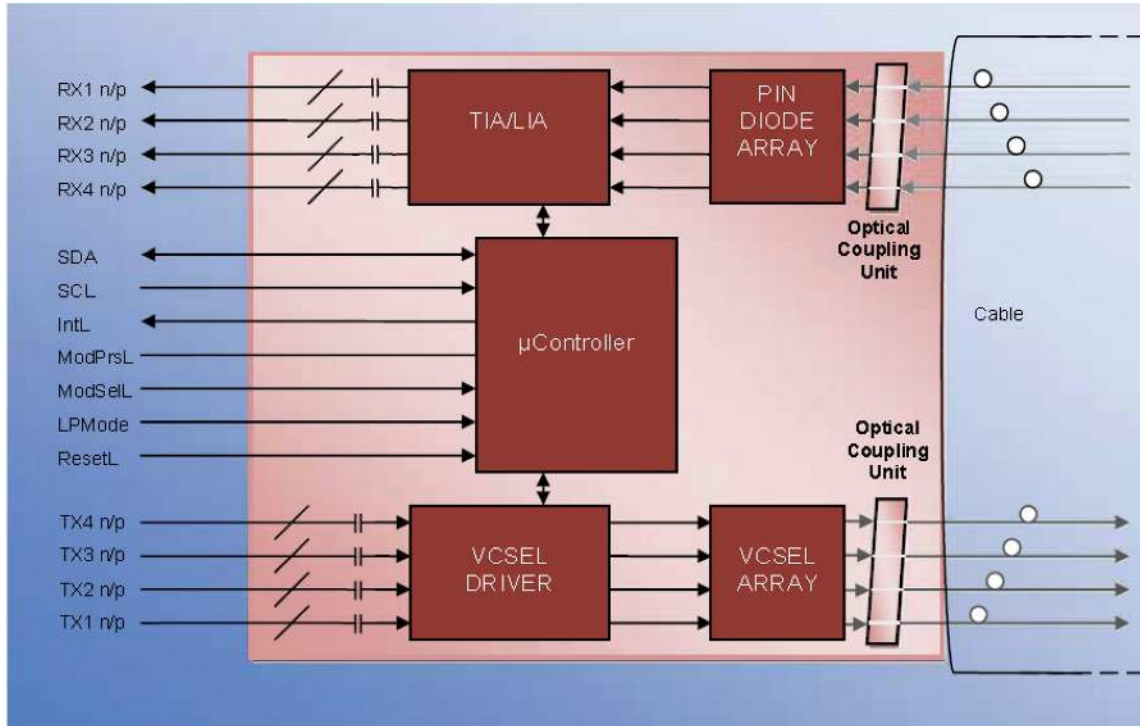

## Absolute Maximum Ratings

Parameter	Symbol	Min	Typ.	Max.	Unit
Storage Temperature	Ts	-20		85	°C
Operating case Temperature	Top	0		70	°C
Power Supply Voltage	Vcc	-0.5		3.6	V
Relative Humidity (non-condensation)	RH	0		85	%

## Recommended Operating Conditions and Power Supply Requirements

Parameter	Symbol	Min	Typ.	Max.	Unit
Operating Case Temperature	Top	-20		85	°C
Power Supply Voltage	Vcc	3.135	3.3	3.465	V
Data Rate, each Lane			25.78125		GB/s
Data Rate Accuracy		-100		100	ppm
Control Input Voltage High		2		Vcc	V
Control Input Voltage Low		0		0.8	V

## Electrical Characteristics

Parameter	Test Point	Min.	Typical	Max	Units	Notes
Power Consumption				2.5	W	1
Supply Current	I <sub>cc</sub>			757	mA	1
<b>Transmitter (each lane)</b>						
Overload Differential Voltage	TP1a	900			mV	
Common Mode Voltage (V <sub>cm</sub> )	TP1	-350		2825	mV	2
Differential Termination Resistance Mismatch	TP1			10	%	At 1MHz
Differential Return Loss (SDD11)	TP1			See CEI-28GOVSR Equation 13-19	dB	
Common Mode to Differential conversion and Differential to Common Mode conversion	TP1			See CEI-28G-VSR Equation 13-20	dB	
Stressed Input Test	TP1a	See CEI-28G-VSR Section 13.3.11.2.1				
<b>Receiver (each lane)</b>						
Differential Voltage, pk-pk	TP4			900	mV	
Common Mode Voltage (V <sub>cm</sub> )	TP4	-350		2850	mV	2
Common Mode Noise, RMS	TP4			17.5	mV	
Differential Termination Resistance Mismatch	TP4			10	%	At 1MHz
Differential Return Loss (SDD22)	TP4			See CEI-28G-VSR Equation 13-19	dB	
Common Mode to Differential conversion and Differential to Common Mode conversion (SCC22)	TP4			-2	dB	3
Transition Time, 20 to 80%	TP4	9.5			Ps	
Vertical Eye Closure (VEC)	TP4			5.5	dB	
Eye Width at 10 <sup>-15</sup> Probability (EW15)	TP4	0.57			UI	
Eye Height at 10-15 Probability (EH15)	TP4	0.57			UI	

### Notes:

1. Per terminal.
2. V<sub>cm</sub> is generated by the host. Specification includes effects of ground offset voltage.
3. From 250MHz to 30GHz

## Pin Descriptions

Pin	Logic	Symbol	Name/Descriptions	Ref.
1		GND	Module Ground	1
2	CML-I	Tx2-	Transmitter inverted data input	
3	CML-I	Tx2+	Transmitter non-inverted data input	
4		GND	Module Ground	1
5	CML-I	Tx4-	Transmitter inverted data input	
6	CML-I	Tx4+	Transmitter non-inverted data input	
7		GND	Module Ground	1
8	LVTTTL-I	MODSEIL	Module Select	2
9	LVTTTL-I	ResetL	Module Reset	2
10		VCCRx	+3.3v Receiver Power Supply	
11	LVCNOS-I	SCL	2-wire Serial interface clock	2
12	LVCNOS-I/O	SDA	2-wire Serial interface data	2
13		GND	Module Ground	1
14	CML-O	RX3+	Receiver non-inverted data output	
15	CML-O	RX3-	Receiver inverted data output	
16		GND	Module Ground	1
17	CML-O	RX1+	Receiver non-inverted data output	
18	CML-O	RX1-	Receiver inverted data output	
19		GND	Module Ground	1
20		GND	Module Ground	1
21	CML-O	RX2-	Receiver inverted data output	
22	CML-O	RX2+	Receiver non-inverted data output	
23		GND	Module Ground	1
24	CML-O	RX4-	Receiver inverted data output	
25	CML-O	RX4+	Receiver non-inverted data output	
26		GND	Module Ground	1
27	LVTTTL-O	ModPrsL	Module Present, internal pulled down to GND	
28	LVTTTL-O	IntL	Interrupt output should be pulled up on host board	2
29		VCCTx	+3.3v Transmitter Power Supply	
30		VCC1	+3.3v Power Supply	
31	LVTTTL-I	LPMode	Low Power Mode	2
32		GND	Module Ground	1
33	CML-I	Tx3+	Transmitter non-inverted data input	
34	CML-I	Tx3-	Transmitter inverted data input	
35		GND	Module Ground	1
36	CML-I	Tx1+	Transmitter non-inverted data input	
37	CML-I	Tx1-	Transmitter inverted data input	
38		GND	Module Ground	1

**Notes:**

1. Module circuit ground is isolated from module chassis ground with in the module.
2. Open collector; should be pulled up with 4.7k-10k ohms on host board to a voltage between 3.15V and 3.6V.

**Electrical Pin-out Details**

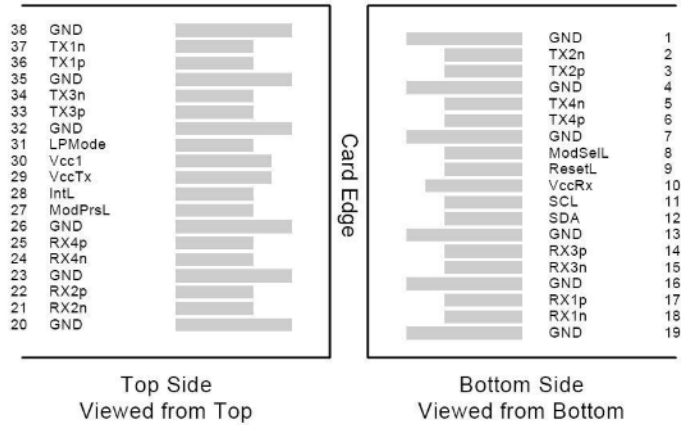

**Recommended Power Supply Filter**

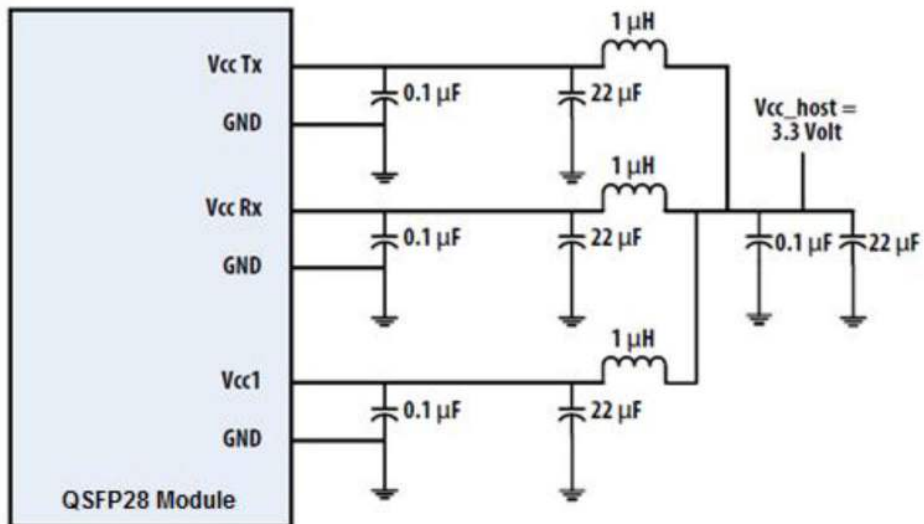

**Mechanical Specification**

