

Using the UCD3138PFCEVM-026

User's Guide



Literature Number: SLUU885B
March 2012—Revised July 2012



WARNING

Always follow TI's set-up and application instructions, including use of all interface components within their recommended electrical rated voltage and power limits. Always use electrical safety precautions to help ensure your personal safety and the safety of those working around you. Contact TI's Product Information Center <http://support.ti.com> for further information.

Save all warnings and instructions for future reference.

Failure to follow warnings and instructions may result in personal injury, property damage, or death due to electrical shock and/or burn hazards.

The term TI HV EVM refers to an electronic device typically provided as an open framed, unenclosed printed circuit board assembly. It is intended strictly for use in development laboratory environments, solely for qualified professional users having training, expertise, and knowledge of electrical safety risks in development and application of high-voltage electrical circuits. Any other use and/or application are strictly prohibited by Texas Instruments. If you are not suitably qualified, you should immediately stop from further use of the HV EVM.

1. Work Area Safety:

- (a) Keep work area clean and orderly.
- (b) Qualified observer(s) must be present anytime circuits are energized.
- (c) Effective barriers and signage must be present in the area where the TI HV EVM and its interface electronics are energized, indicating operation of accessible high voltages may be present, for the purpose of protecting inadvertent access.
- (d) All interface circuits, power supplies, evaluation modules, instruments, meters, scopes and other related apparatus used in a development environment exceeding 50 V_{RMS}/75 VDC must be electrically located within a protected Emergency Power Off (EPO) protected power strip.
- (e) Use a stable and non-conductive work surface.
- (f) Use adequately insulated clamps and wires to attach measurement probes and instruments. No freehand testing whenever possible.

2. Electrical Safety:

- (a) De-energize the TI HV EVM and all its inputs, outputs, and electrical loads before performing any electrical or other diagnostic measurements. Revalidate that TI HV EVM power has been safely de-energized.
- (b) With the EVM confirmed de-energized, proceed with required electrical circuit configurations, wiring, measurement equipment hook-ups and other application needs, while still assuming the EVM circuit and measuring instruments are electrically live.
- (c) Once EVM readiness is complete, energize the EVM as intended.

WARNING: while the EVM is energized, never touch the EVM or its electrical circuits as they could be at high voltages capable of causing electrical shock hazard.

3. Personal Safety:

- (a) Wear personal protective equipment e.g. latex gloves and/or safety glasses with side shields or protect EVM in an adequate lucent plastic box with interlocks from accidental touch.

4. Limitation for Safe Use:

- (a) EVMs are not to be used as all or part of a production unit.

Digitally Controlled Single-Phase PFC Pre-Regulator

1 Introduction

This EVM is to help evaluate the UCD3138 64-pin digital control device in off-line power converter application and then to aid its design. The EVM is a standalone Power Factor Correction (PFC) pre-regulator of single-phase AC input. The EVM UCD3138PFCEVM-026 is used together with its control card, UCD3138CC64EVM-030, also an EVM on which is placed UCD3138RGC.

The EVM of UCD3138PFCEVM-026 together with UCD3138CC64EVM-030 can be used as they are delivered without additional work, from either hardware or firmware, to evaluate PFC. The UCD3138PFCEVM-026 together with the UCD3138CC64EVM-030 can also be re-tuned on its design parameters through the operation of GUI, called [Texas Instruments Fusion Digital Power Designer](#), or re-loaded up with custom firmware with user's definition and development.

The EVM system is in topology of single-phase boost converter at its delivery on both hardware and firmware, but can be re-configured into two other PFC topologies: dual-phase interleaved, and bridgeless, then corresponding operation can be made by reloading with that associated firmware. All necessity of hardware and firmware for the two additional topologies are already developed and delivered with the shipment. Please contact Texas Instruments to obtain the instructions how to make re-configuration.

In the package delivered, three EVMs are included UCD3138PFCEVM-026, UCD3138CC64EVM-030, and USB-TO-GPIO. In the same package, also included is a hard copy of *Evaluation Module Electrical Safety Guideline*.

This user's guide provides basic evaluation instruction from a viewpoint of system operation in standalone PFC in its boost configuration.

2 Description

UCD3138PFCEVM-026 together with UCD3138CC64EVM-030 is an EVM of PFC pre-regulator with digital control using UCD3138 device in boost converter topology and in the application of single-phase AC input. UCD3138 device is located on the board of UCD3138CC64EVM-030. UCD3138CC64EVM-030 is a daughter card and serves all PFC required control functions with preloaded single-phase boost PFC firmware. UCD3138PFCEVM-026 accepts universal AC line input from 90 V_{AC} to 264 V_{AC}, and outputs nominal 390 V_{DC} with full load output power 360 W, or full output current 0.92 A.

2.1 Typical Applications

- Single-Phase Universal AC Line Power Factor Correction Pre-Regulator
- Servers
- Telecommunication Systems

2.2 Features

- Digitally Controlled PFC Pre-Regulator
- Universal AC Line Input from 90 V_{AC} to 264 V_{AC} with AC Line Frequency 47 Hz to 63 Hz
- Regulated Output 390 V_{DC} with Output from No-Load to Full-Load
- Full-Load Power 360 W, or full-Load Current 0.92 A
- High Power Factor Close to 0.999 and Low THD Below 5% in Most Operation Conditions
- High Efficiency
- Protection:
 - Over Voltage
 - Over Current
 - Brownout
 - Power-On Inrush Current
- Test Points to Facilitate Device and Topology Evaluation
- Re-Configurable to Dual-Phase Interleaved PFC or Bridgeless PFC (please contact TI for detail)

3 Electrical Performance Specifications

Table 1. UCD3138PFCEVM-026 Electrical Performance Specifications

PARAMETER	TEST CONDITIONS	MIN	TYP	MAX	UNITS
Input Characteristics					
Voltage range		90		264	VAC
Line frequency		47		63	Hz
Input current, peak	Input = 90 VAC, 60 Hz, full load = 0.92 A		6.5	7.0	A
Input current, RMS	Input = 90 VAC, 60 Hz, full load = 0.92 A		4.5	5.5	
Input UVLO On	PFC function start (no load)	86		90	VAC
Input UVLO Off	PFC function stop (no load)	80		83	
Power factor	Half load		0.99		-
THD, input current	10% to 30% full load		10%		
	30% to 100% full load		5%		
Output Characteristics					
Output voltage, V_{OUT}	No load to full load		390		VDC
Output load current, I_{OUT}	90 VAC to 264 VAC			0.92	A
Output voltage ripple	Full load and 115 VAC, 60 Hz		13		Vpp
	Full load and 230 VAC, 50 Hz		15		
Output over current		0.95			A
Systems Characteristics					
Switching frequency	Normal operation		100		kHz
Peak efficiency	230 VAC, full load		96%		
Full load efficiency	115 VAC, full load		94%		
Operating temperature	Natural convection		25		°C

4 Schematics

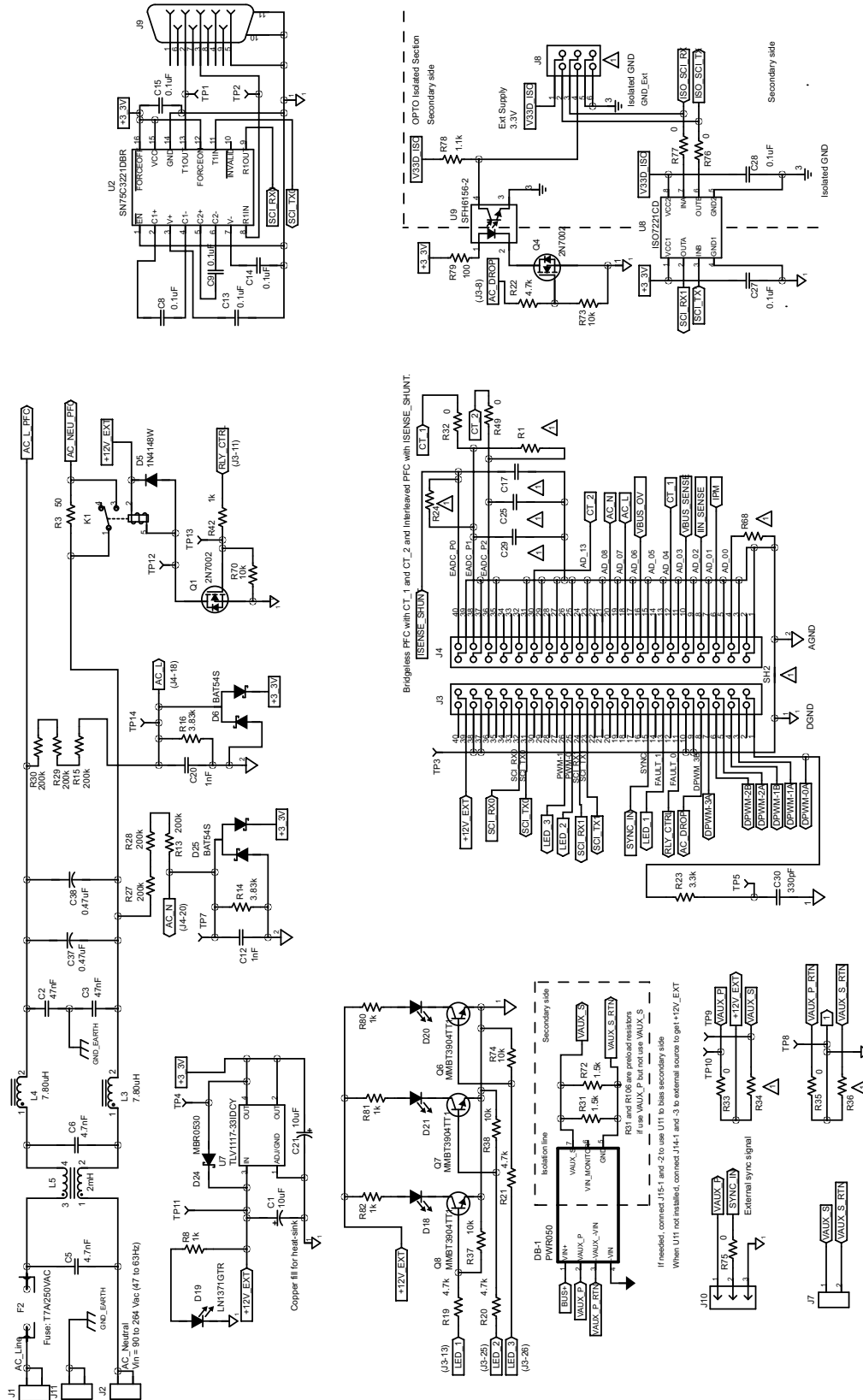

Figure 1. UCD3138PFCEVM-026 Schematic

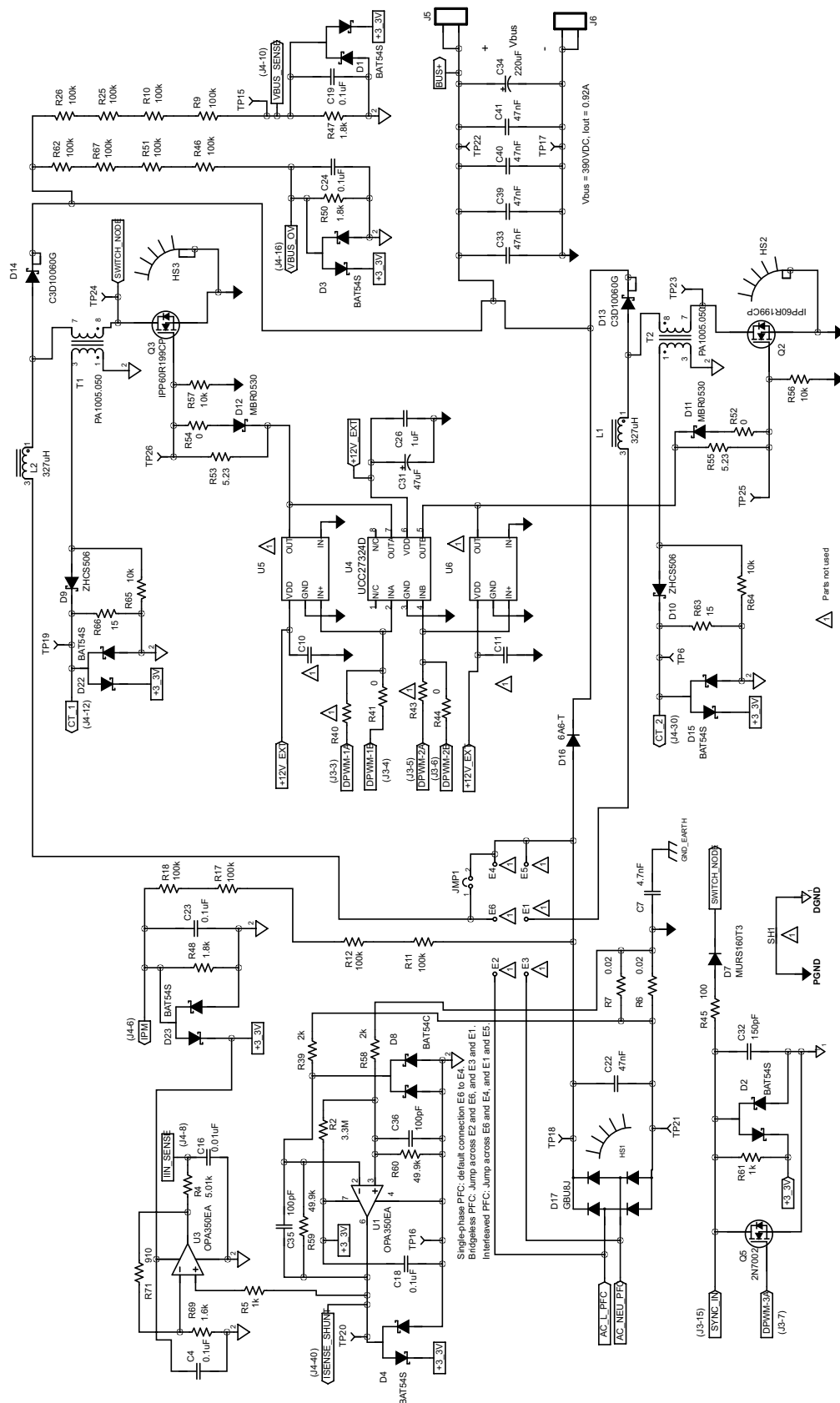

Figure 2. UCD3138PFC EVM-026 Schematic

5 Test Setup

5.1 Test Equipment

AC Voltage Source: capable of single-phase output AC voltage $85 V_{AC}$ to $265 V_{AC}$, 47 Hz to 63 Hz, adjustable, with minimum power rating 400 W, the AC voltage source to be used should meet IEC60950 reinforced insulation requirement.

DC Multimeter: capable of 0-V to 500-V input range, four digits display preferred.

Output Load: DC load capable of 400 V_{DC} or greater, 1 A or greater, and 400 W or greater, with display such as load current and load power.

Oscilloscope: capable of 500-MHz full bandwidth, digital or analog, if digital 5 Gs/s or better.

Current probe: capable of 0 A to 10 A, 100-MHz or greater full bandwidth, AC coupling.

Fan: 200 LFM to 400 LFM forced air cooling is recommended, but not a must.

Recommended Wire Gauge: capable of 4-A RMS, or better than #16 AWG, with the total length of wire less than 8 feet (4 feet input and 4 feet return).

5.2 Recommended Test Setup

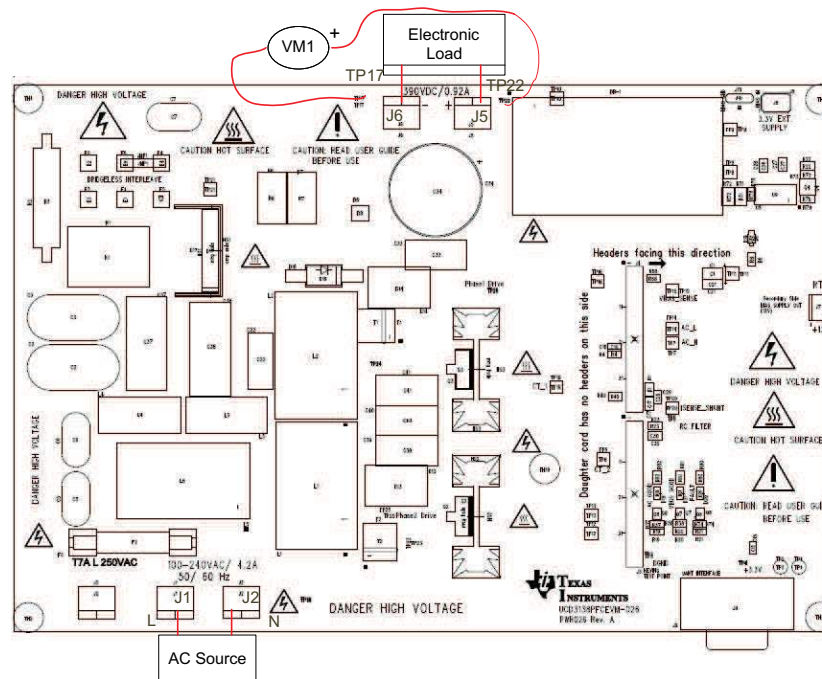

Figure 3. UCD3138PFCEVM-026 Recommended Test Setup

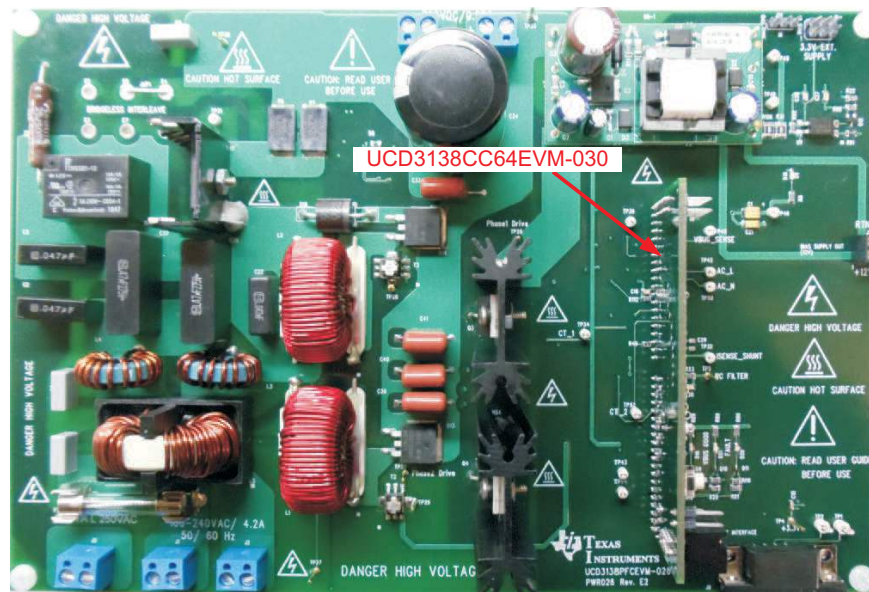

Figure 4. EVM Orientation of UCD3138PFCEVM-030 on the UCD3138PFCEVM-026

6 List of Test Points

Table 2. List of Test Points

TEST POINTS	NAME	DESCRIPTION
TP1	T1OUT	UART0 (J9-2) T1OUT
TP2	R1IN	UART0 (J9-3) R1IN
TP3	DGND	Digital GND of J3 connection
TP4	+3_3V	3.3-V LDO output on board from 12 V
TP5	RC-PWM-0A	DPWM0A RC filter
TP6	CT_2	Second phase current sensing signal
TP7	AC_N	Input voltage sensing signal of Neutral wire
TP8	DGND	Digital GND and same as TP3
TP9	VAUX_S	Secondary side 12 V on board. Not used, but can be used for external circuit.
TP10	VAUX_P	12-V output on board from DB-1, UCC28600EVM400V-12V
TP11	+12V_EXT	12 V on board from VAUX_P
TP12	K1	Relay K1 coil
TP14	AC_L	Input sensing signal of Line wire
TP15	VBUS_SENSE	PFC output voltage sensing signal
TP16	GND	Analog GND
TP17	BUS-	PFC output return
TP18	REC-1	Rectifier positive output
TP19	CT-1	Current sensing signal from current transformer T1
TP20	ISENSE	Current sensing signal after conditioning
TP21	REC-2	Rectifier return
TP22	BUS+	PFC output positive, nominal 390VDC
TP23	SW2	Q2 Drain pin
TP24	SW1	Q3 Drain pin
TP25	Q2-Gate	Gate pin of Q2 MOSFET
TP26	Q3-Gate	Gate pin of Q3 MOSFET

7 List of Terminals

Table 3. List of Terminals

TERMINAL	NAME	DESCRIPTION
J1	Line	Board AC input line, single-pin connection – screw type, J1 and J2 are AC input terminals, rated up to 264 V _{AC} and maximum 7.5 A, 47 Hz to 63 Hz.
J2	Neutral	Board AC input neutral, single-pin connection – screw type
J3	DJ	Digital signal connection, 40 pins
J4	AJ	Analog signal connection, 40 pins
J5	BUS+	PFC output positive connection, single-pin connection – screw type, BUS+ and BUS- are DC output terminals, rated maximum 400 V _{DC} , and maximum current 1 A.
J6	BUS-	PFC output return, single-pin connection – screw type
J7	12V_Sec	12-V auxiliary to supply to external circuit on the secondary side, 2 pins
J8	UART1	Isolated and communication to DC converter, not production tested, 6 pins
J9	UART0	Non-isolated connection, standard RS232, 9 pins,
J10	Sync	External 12-V bias and sync signal, 3 pins
J11	Chassis	Chassis ground, or earth connection, single-pin connection – screw type

8 Test Procedure

8.1 Efficiency Measurement Procedure

1. Refer to [Figure 3](#) for basic setup to measure power conversion efficiency. The required equipment to do this measurement is listed in [Section 5.1](#).
2. Before making electrical connections, visually check the boards to make sure there are no suspected spots of damages.
3. In this EVM package, three EVMs are included, UCD3138PFCEVM-026, UCD3138CC64EVM-030, and USB-TO-GPIO. In this measurement, the board of UCD3138PFCEVM-026 and UCD3138CC64EVM-030 is needed.
4. First install the board of UCD3138CC64EVM-030 onto the board of UCD3138PFCEVM-026. Care must be given to the alignment and the orientation of two boards, or damage may occur. Refer to [Figure 4](#) for UCD3138CC64EVM-030 board orientation.
5. Connect the AC voltage source to J1 (Line) and J2 (Neutral). The AC voltage source should be an isolated one and meet IEC60950 requirement. Set up the AC output voltage in the range specified in [Table 1](#), between $90 V_{AC}$ and $264 V_{AC}$, between 47 Hz and 63 Hz; set up the AC source current limit to 7.5-A peak and RMS, respectively.
6. Connect an electronic load with either constant current mode or constant resistance mode. The load range is from 0 A to 0.92 A. Initial power on is recommended with 0-A load current. The load is required to receive $0 V_{DC}$ to $500 V_{DC}$.
7. If the load does not have a current or a power display, a current meter is needed to insert into between the load and the board.
8. Connect a volt-meter across the load and set up the volt-meter scale 0 V to 500 V on its voltage, DC.
9. Turn on the AC voltage output and varying the load. Then the measurement can be made.

WARNING

Danger of Electrical Shock! High voltage present during the measurement!

Danger of Heat Burn from High Temperature!

Do not leave EVM powered when unattended!

8.2 Equipment Shutdown

1. Shut down AC voltage source.
2. Shut down electronic load.

9 Performance Data and Typical Characteristic Curves

Figure 5 through Figure 18 present typical performance curves for UCD3138PFCEVM-026.

9.1 Efficiency

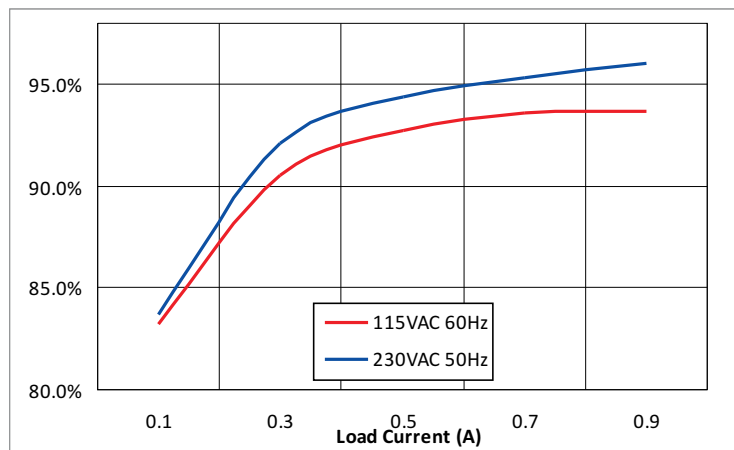

Figure 5. UCD3138PFCEVM-026 Efficiency

9.2 Power Factor

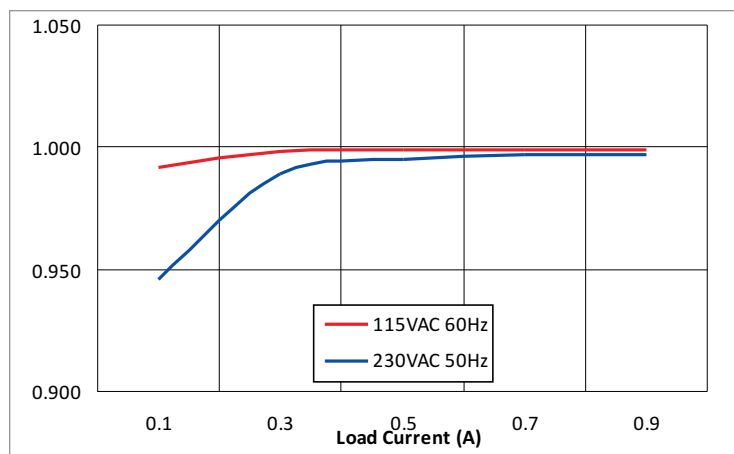

Figure 6. UCD3138PFCEVM-026 Power Factor

9.3 Input Current at 115 V_{AC} and 60 Hz

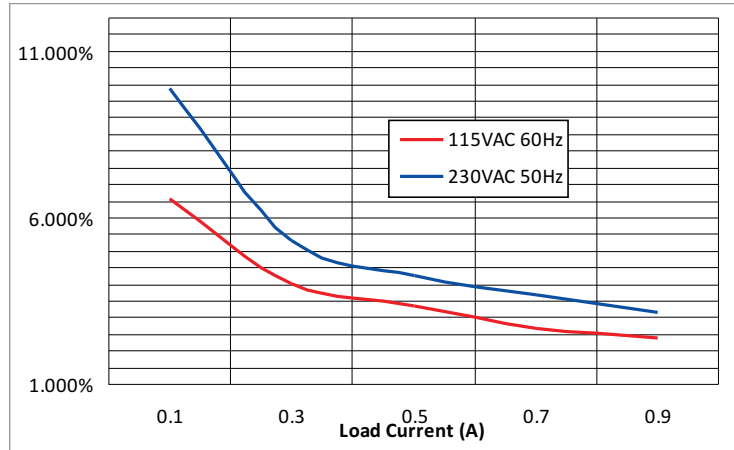

Figure 7. Input Current and Voltage 115 V_{AC} and Half Load

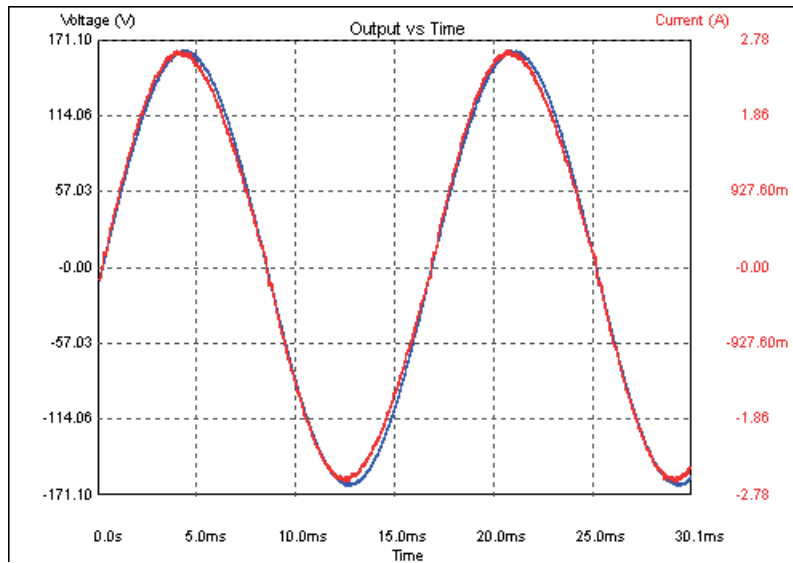

Figure 8. Input Current and Voltage 115 V_{AC} and Full Load

9.4 Input Current at 230 V_{AC} and 50 Hz

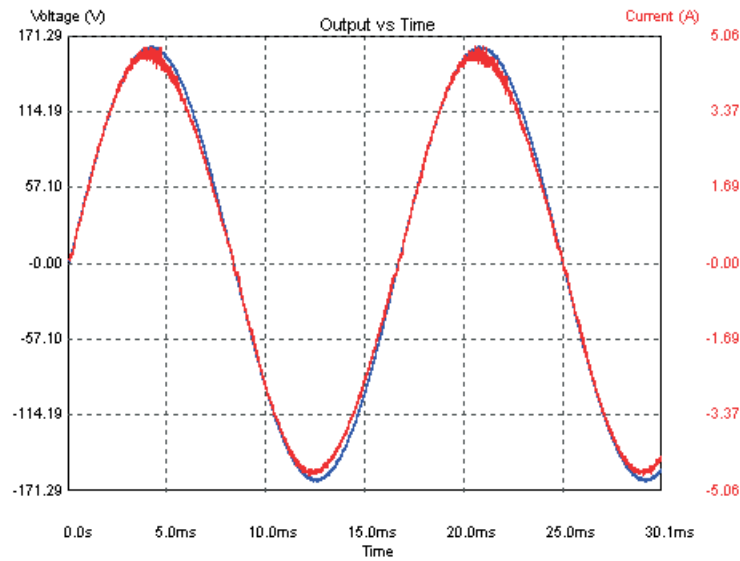

Figure 9. Input Current and Voltage 230 V_{AC} and Half Load

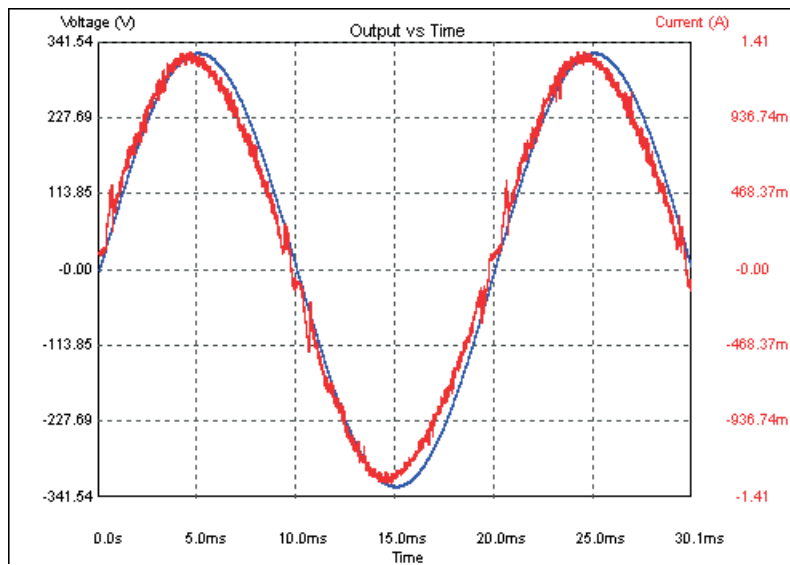

Figure 10. Input Current and Voltage 230 V_{AC} and Full Load

9.5 Output Voltage Ripple

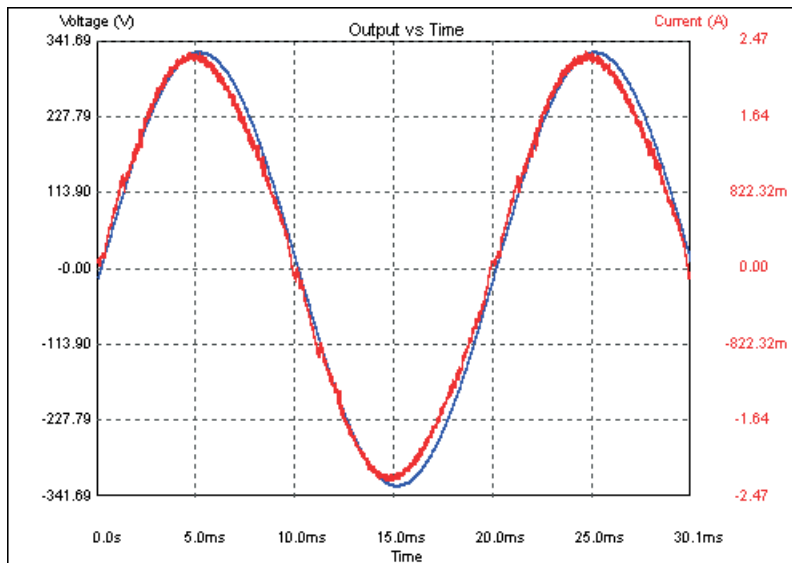

Figure 11. Output Voltage Ripple 115 V_{AC} and Full Load

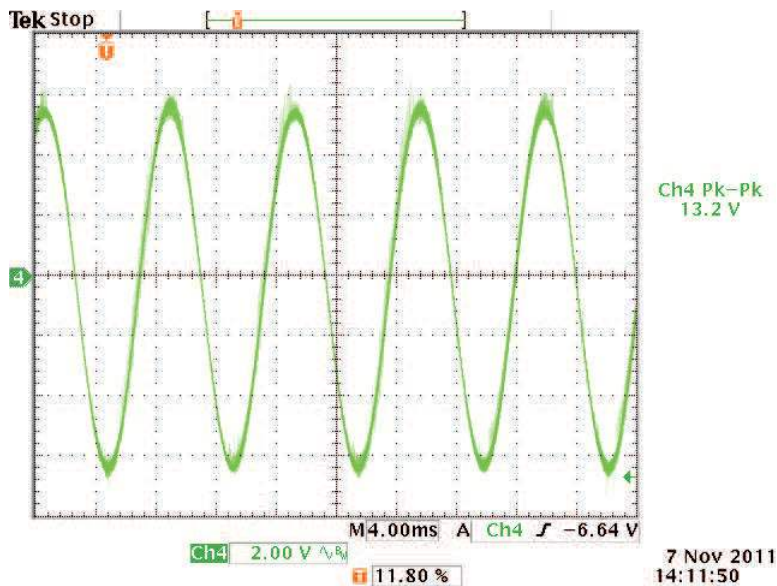

Figure 12. Output Voltage Ripple 230 V_{AC} and Full Load

9.6 Output Turn On

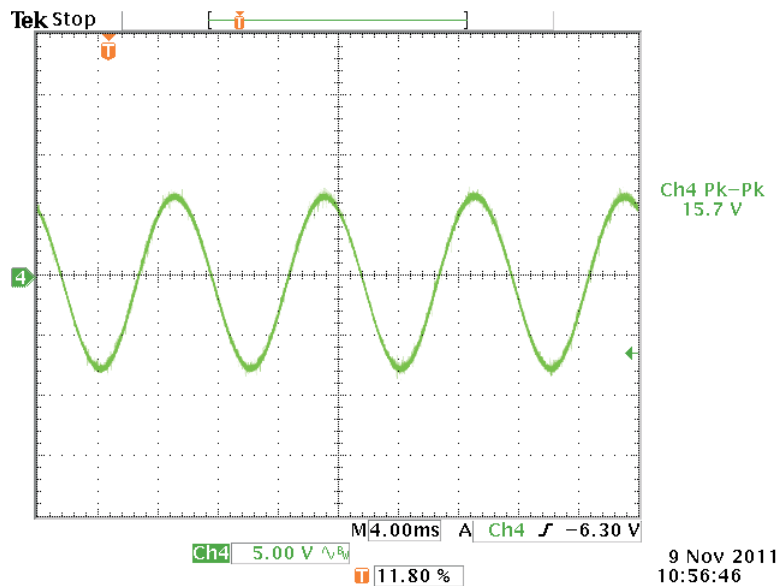

Figure 13. Output Turn On 115 V_{AC} and No Load

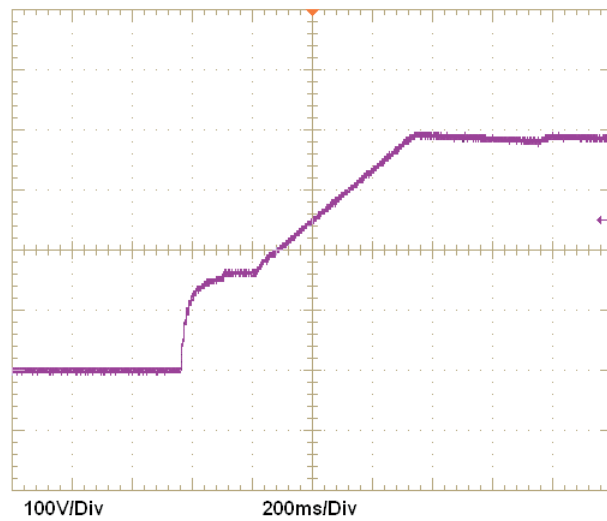

Figure 14. Output Turn On 115 V_{AC} and Full Load

9.7 Total Harmonic Distortion (THD)

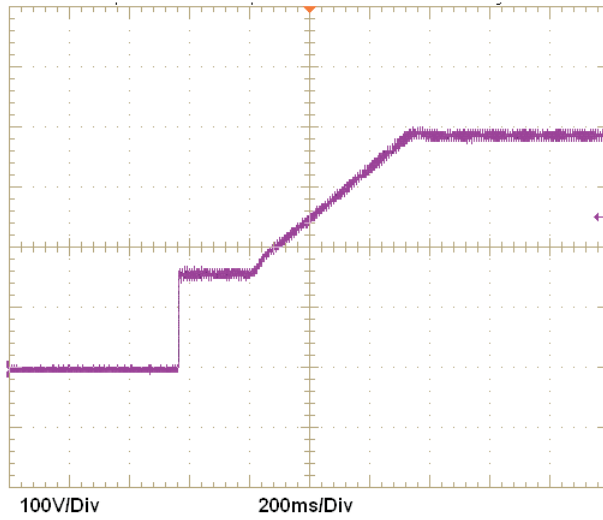

Figure 15. UCD3138PFCEVM-026 Input Current THD

9.8 Other Waveforms

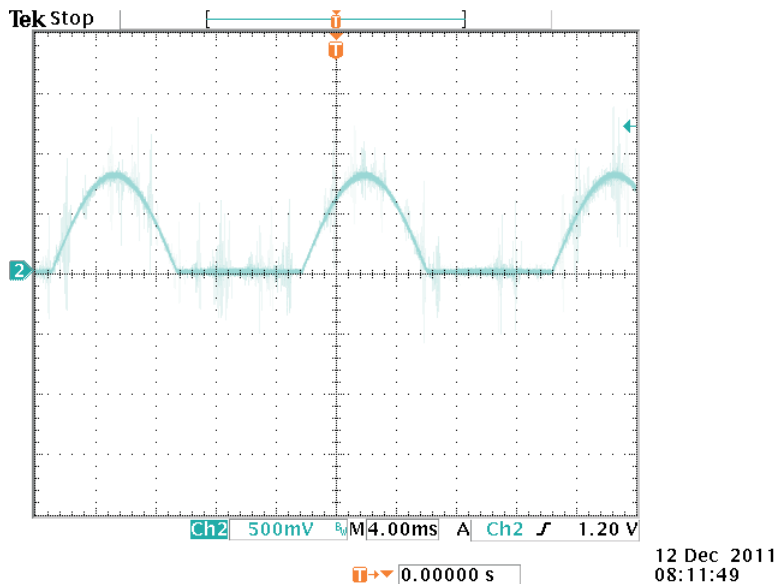

Figure 16. UCD3138PFCEVM-026 Sensing Signal AC_L (TP14) or AC_N (TP7)

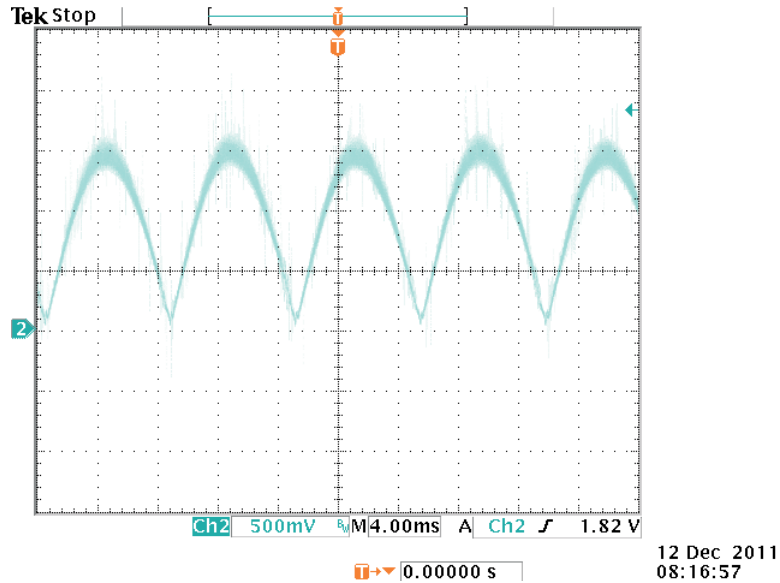

Figure 17. UCD3138PFCEVM-026 Sensing Signal I_{SENSE} (TP20)

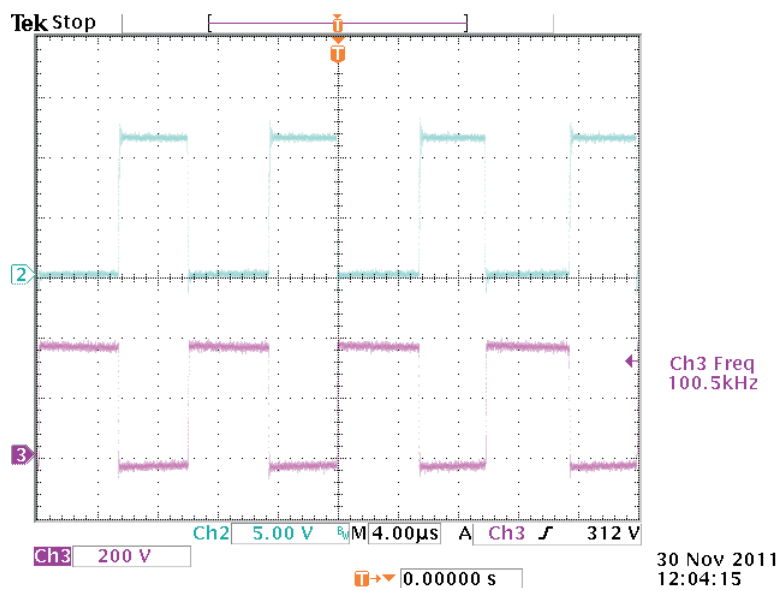

Figure 18. UCD3138PFCEVM-026 MOSFET V_{GS} (top) and V_{DS}

10 EVM Assembly Drawing and PCB Layout

The following figures (Figure 19 through Figure 24) show the design of the UCD3138PFCEVM-026 printed circuit board. PCB dimensions: L x W = 9.0 inch x 6.0 inch, PCB material: FR4 or compatible, four layers and 2-oz copper on each layer.

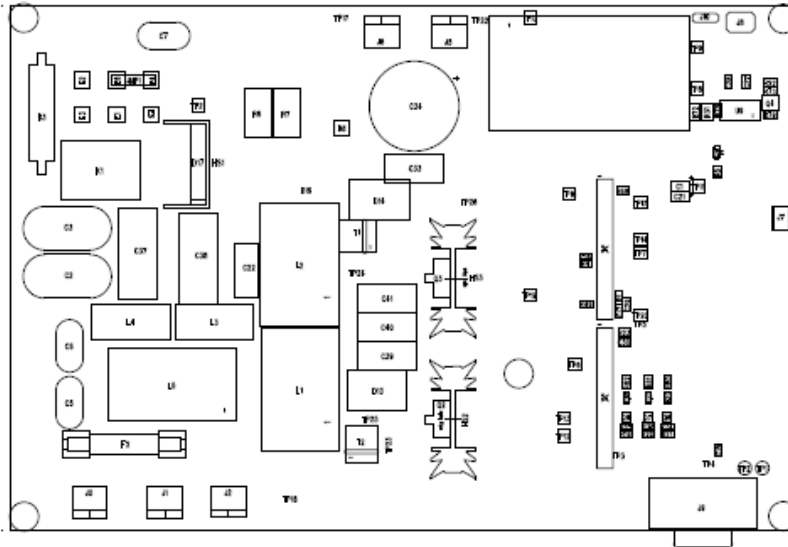

Figure 19. UCD3138PFCEVM-026 Top Layer Assembly Drawing (top view)

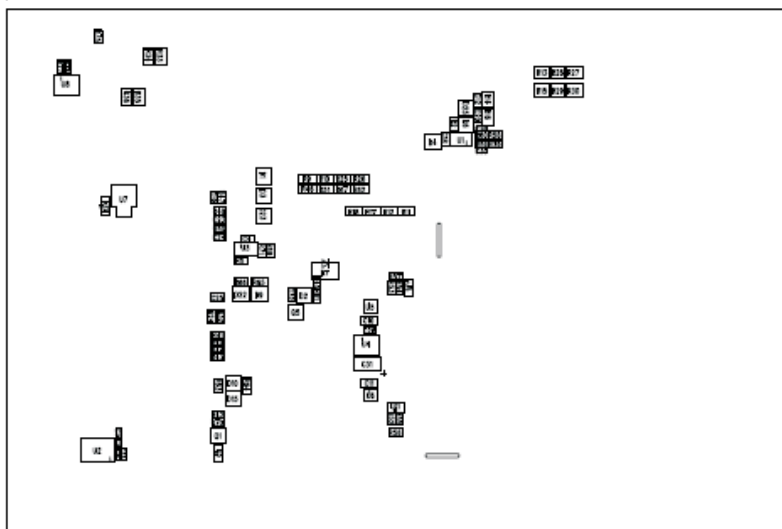

Figure 20. UCD3138PFCEVM-026 Bottom Assembly Drawing (bottom view)

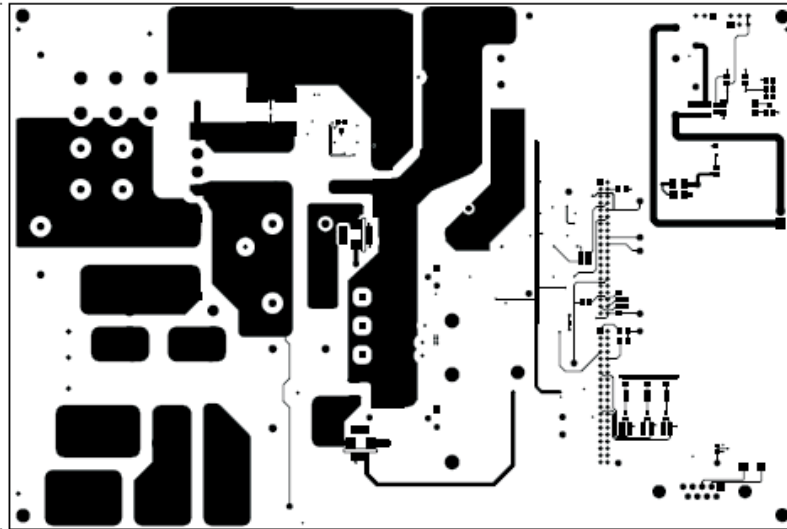

Figure 21. UCD3138PFCEVM-026 Top Copper (top view)

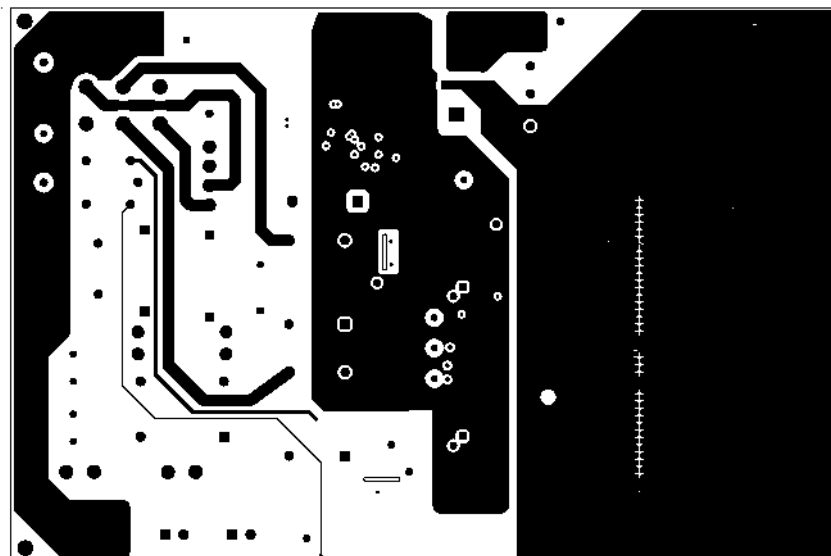

Figure 22. UCD3138PFCEVM-026 Internal Layer 1 (top view)

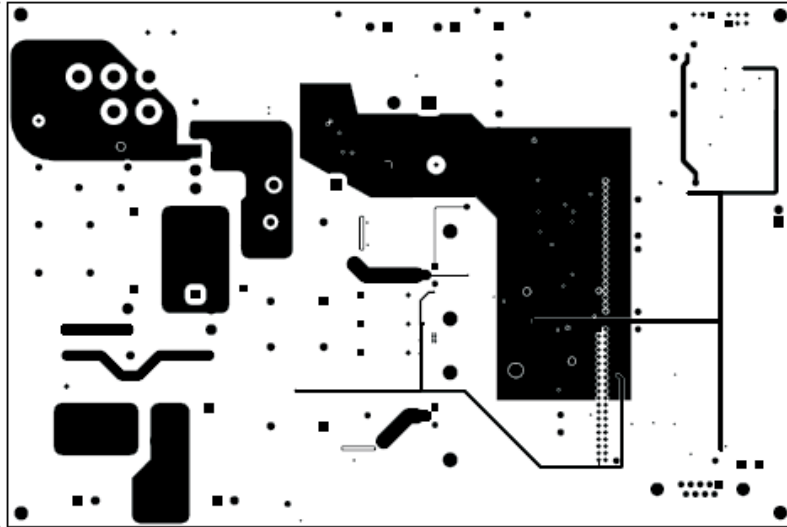

Figure 23. UCD3138PFCEVM-026 Internal Layer 2 (top view)

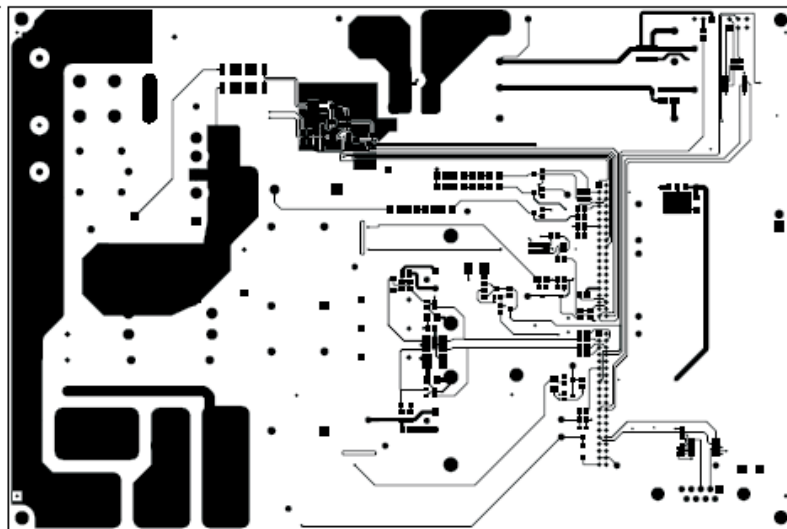

Figure 24. UCD3138PFCEVM-026 Bottom Copper (top view)

11 List of Materials

The List of Materials is Based on [Figure 1](#) and [Figure 2](#).

Table 4. UCD3138PFCEVM-026 List of Materials

QTY	REF DES	DESCRIPTION	PART NUMBER	MFR
1	C1	Capacitor, tantalum, 25 V, 20%, 10 μ F, 3528	TPSB106M025R1800	AVX
0	C10, C11	Capacitor, ceramic, 50 V, X7R, 10%, open, 1206	Std	Std
2	C12, C20	Capacitor, ceramic, 50 V, X7R, 10%, 1 nF, 0805	Std	Std
1	C16	Capacitor, ceramic, 50 V, X7R, 10%, 0.01 μ F, 0805	Std	Std
0	C17, C25, C29	Capacitor, ceramic, 50 V, X7R, 10%, open, 0805	Std	Std
2	C2, C3	Capacitor, metalized polyester, 250 VAC, \pm 20%, 47 nF, 0.472 inch x 0.925 inch	ECQ-U2A473MV	Panasonic
1	C21	Capacitor, tantalum, 10 V, 20%, 10 μ F, 3216	TAJA106M010RNJ	AVX
1	C22	Capacitor, film, 300 VAC, \pm 20%, 47 nF, 0.236 inch x 0.591 inch	ECQ-U3A473MG	Panasonic
1	C26	Capacitor, ceramic, 50 V, X7R, 10%, 1 μ F, 0805	Std	Std
1	C30	Capacitor, ceramic, 50 V, X7R, 10%, 330 pF, 0805	Std	Std
1	C31	Capacitor, tantalum chip, 16 V, 47 μ F, 0.281 inch x 0.126 inch	595D476X9016C2T	Vishay
1	C32	Capacitor, ceramic, 50 V, NP0, 5%, 150 pF, 0805	Std	Std
4	C33, C39, C40, C41	Capacitor, polyester, 630 V, 10%, 47 nF, 0.256 inch x 0.650 inch	ECQ-E6473KF	Panasonic
1	C34	Capacitor, aluminum electrolytic, 450 VDC, -40°C to 85°C, \pm 20%, 220 μ F, 0.984 inch diameter	ECOS2WP221CX	Panasonic
2	C35, C36	Capacitor, ceramic, 50 V, X7R, 10%, 100 pF, 0603	Std	Std
2	C37, C38	Capacitor, film, 275 VAC, \pm 20%, 0.47 μ F, 0.236 inch x 0.591 inch	ECQU2A474ML	Panasonic
7	C4, C18, C19, C23, C24, C27, C28	Capacitor, ceramic, 50 V, X7R, 10%, 0.1 μ F, 0805	Std	Std
3	C5, C6, C7	Capacitor, metalized polyester, 250 VAC, \pm 20%, 4.7 nF, 0.295 inch x 0.730 inch	BFC233820472	Vishay
5	C8, C9, C13, C14, C15	Capacitor, ceramic, 50 V, X7R, 10%, 0.1 μ F, 0603	Std	TDK
9	D1, D2, D3, D4, D6, D15, D22, D23, D25	Diode, dual Schottky, 200 mA, 30 V, SOT23	BAT54S	Zetex
2	D11, D12, D24	Diode, Schottky, 500 mA, 30 V, SOD123	MBR0530T1G	On Semi
2	D13, D14	Diode, Schottky rectifier, 10 A, 600 V, TO-263-2	C3D10060G	CREE
1	D16	Diode, 600 V, 6 A, 400 A peak surge, P600	6A6-T	Diodes
1	D17	Diode, bridge rectifier, 8 A, 600 V, 0.880 inch x 0.140 inch	GBU8J	Fairchild
1	D18	Diode, LED, green, 2.1 V, 20 mA, 6 mcd, 0603	LTST-C190GKT	Lite On
1	D19	Diode, LED, green, 2.1 V, 20 mA, 0.9 mcd, 0.068 inch x 0.049 inch	LN1371GTR	Panasonic
1	D20	Diode, LED, red, 2.1 V, 20 mA, 6 mcd, 0603	LTST-C190CKT	Lite On
1	D21	Diode, LED, yellow, 2.1 V, 20 mA, 6 mcd, 0603	LTST-C190YKT	Lite On
1	D5	Diode, signal, 300 mA, 75 V, 350 mW, SOD-123	1N4148W-TP	MICROSEMI
1	D7	Diode, ultrafast rectifier, 1 A, 200 V, SMB	MURS160T3G	On Semi
1	D8	Diode, dual Schottky, 200 mA, 30 V, SOT-23	BAT54C	Fairchild
2	D9, D10	Diode, Schottky, 500 mA, 60 V, SOT-23	ZHCS506	Zetex
1	DB-1	Module, 5 W, auxiliary bias PS, PCB assembly, 1.200 inch x 2.200 inch	PWR050	TI
1	DB-2	Control card, UCD3138 control card, PCB assembly, 3.400 inch x 1.800 inch	UCD3138CCEVM-030	TI

Table 4. UCD3138PFCEVM-026 List of Materials (continued)

QTY	REF DES	DESCRIPTION	PART NUMBER	MFR
1	F1	Fuse, 250 VAC, SLO-BLO, 3 AG, 7-A cart, 0.250 inch x 1.250 inch	0313007.HXP	Littlefuse
1	F2	Ffuse holder, 1/4 inch, board mount, 1.54 inch x 0.30 inch	BK/1A3398-07	Bussmann
1	HS1	Heatsink, TO-220, vertical mount, 15 x C/W, 0.5 inch x 0.95 inch	593002B00000G	Aavid
2	HS2, HS3	Heatsink, TO-220, vertical mount, 5 x C/W, 0.5 inch x 1.38 inch	513201	Aavid
5	J1, J2, J5, J6, J11	Terminal block, 2 pin, 15 A, 5.1 mm, 0.40 inch x 0.35 inch	ED120/2DS	OST
1	J10	Header, male 3 pin, 100-mil spacing, 0.100 inch x 3 inch	PEC03SAAN	Sullins
2	J3, J4	Header, 40 pin, 2 mm pitch, 4.00 mm x 40.00 mm	87758-4016	Molex
1	J7	Terminal block, 2 pin, 6 A, 3.5 mm, 0.27 inch x 0.25 inch	ED555/2DS	OST
1	J8	Header, male 2 x 3 pin, 100-mil spacing, 0.20 inch x 0.30 inch	PEC03DAAN	Sullins
1	J9	Connector, 9-pin D, right angle, female, 1.213 inch x 0.510 inch	182-009-213R171	Norcomp
1	JMP1	Jumper, 0.400 inch length, bare, solid, bus-bar wire, AWG 16, 0.051 inch	295 SV005	ALPHA WIRE
1	K1	Relay, SPDT, 10-A miniature, 12-V coil, 0.630 inch x 0.870 inch	T7NS5D1-12	Tyco
2	L1, L2	Inductor, toroid, 327 μ H, vertical THT, 327 μ H, 0.866 inch x 1.380 inch	7804-09-0014	Nova Magnetics
2	L3, L4	Inductor, toroid, 7.8 μ H at 0 A and 3.22 μ H at 20.5 A, 7.80 μ H, 0.874 inch x 0.374 inch	PA0431L	Pulse
1	L5	IND, common mode emi suppression, 7.5 A, 2 mH at 1 kHz, 2 mH, 0.800 inch x 1.440 inch	PE-62917	Pulse
3	Q1, Q4, Q5	MOSFET, N-channel, 60 V, 115 mA, 1.2 Ω , SOT23	2N7002	Fairchild
2	Q2, Q3	MOSFET, N-channel, 650 V, 9 A, 199 m Ω , TO-220V	IPP60R199CP	Infineon
3	Q6, Q7, Q8	Bipolar, NPN, 40 V, 200 mA, 200 mW, SC-75	MMBT3904TT1G	On Semi
0	R1, R24, R40, R43, R68	Resistor, chip, 1/10 W, 1%, open, 0805	Std	Std
6	R13, R15, R27, R28, R29, R30	Resistor, chip, 1/4 W, 1%, 200 k Ω , 1210	Std	Std
2	R14, R16	Resistor, chip, 1/4 W, 1%, 3.83 k Ω , 1210	Std	Std
4	R19, R20, R21, R22	Resistor, chip, 1/10 W, 1%, 4.7 k Ω , 0805	Std	Std
1	R2	Resistor, chip, 1/10 W, 1%, 3.3 M Ω , 0805	Std	Std
1	R23	Resistor, chip, 1/10 W, 1%, 3.3 k Ω , 0805	Std	Std
1	R3	Resistor, wire-wound, 5 W, 5%, 50 Ω , 1.000 inch x 0.276 inch	25J50RE	Ohmite
2	R31, R72	Resistor, chip, 1/4 W, 1%, 1.5 k Ω , 1210	Std	Std
9	R32, R41, R44, R49, R52, R54, R75, R76, R77	Resistor, chip, 1/10 W, 1%, 0 Ω , 0805	Std	Std
2	R33, R35	Resistor, chip, 1/4 W, 1%, 0 Ω , 1210	Std	Std
0	R34, R36	Resistor, chip, 1/4 W, 1%, open, 1210	Std	Std

Table 4. UCD3138PFCEVM-026 List of Materials (continued)

QTY	REF DES	DESCRIPTION	PART NUMBER	MFR
7	R37, R38, R56, R57, R70, R73, R74	Resistor, chip, 1/10 W, 1%, 10 k Ω , 0805	Std	Std
2	R39, R58	Resistor, chip, 1/10 W, 1%, 2 k Ω , 0805	Std	Std
1	R4	Resistor, chip, 1/10 W, 1%, 5.01 k Ω , 0805	Std	Std
2	R45, R79	Resistor, chip, 1/10 W, 1%, 100 Ω , 0805	Std	Std
3	R47, R48, R50	Resistor, chip, 1/10 W, 1%, 1.8 k Ω , 0805	Std	Std
7	R5, R8, R42, R61, R80, R81, R82	Resistor, chip, 1/10 W, 1%, 1 k Ω , 0805	Std	Std
2	R53, R55	Resistor, chip, 1/10 W, 1%, 5.23 Ω , 0805	Std	std
2	R59, R60	Resistor, chip, 1/10 W, 1%, 49.9 k Ω , 0805	Std	Std
2	R6, R7	Resistor, metal strip, 2 W, 1%, 0.02 Ω , 0.49 inch x 0.10 inch	WSR2R0200FEA	Vishay Dale
2	R63, R66	Resistor, chip, 1/10 W, 1%, 15 Ω , 0805	Std	Std
2	R64, R65	Resistor, chip, 1/10 W, 1%, 10 k Ω , 1206	Std	std
1	R69	Resistor, chip, 1/10 W, 1%, 1.6 k Ω , 0805	Std	Std
1	R71	Resistor, chip, 1/10 W, 1%, 910 Ω , 0805	Std	Std
1	R78	Resistor, chip, 1/10 W, 1%, 1.1 k Ω , 0805	Std	Std
12	R9, R10, R11, R12, R17, R18, R25, R26, R46, R51, R62, R67	Resistor, metal film, 1/4 W, \pm 5%, 100 k Ω , 1206	RC1206FR-07100KL	Yageo
2	U1, U3	High Voltage, High Current Op-Amp, MSOP-8	OPA350EA/250	TI
1	U2	RS-232 Transceivers with Auto Shutdown, SSOP-16	SN75C3221DBR	TI
1	U4	High-Speed Low-Side Power MOSFET driver, SO8	UCC27324D	TI
0	U5, U6	4-A Single Channel High-Speed Low-Side Gate Drivers, open, SOT23-6	UCC27517DBV	TI
1	U7	3.3-V, 800-mA LDO Voltage Regulators, SOT-223	TLV1117-33IDCY	TI
1	U8	Digital Isolators, xx Mbps, SO-8	ISO7221CD	TI
1	U9	Opto-coupler, SMD-4P	SFH6156-2	Vishay

12 Digital PFC Description

12.1 1PFC Block Diagram

12.1.1 Single-Phase PFC Block Diagram

Single-phase PFC function block diagram is shown in [Figure 25](#). The digital controlled single-phase PFC has the same power stage as those seen in other analog controlled devices. The main difference is the line voltage is sensed then rectified inside the UCD3138 digital controller. All signals interact with UCD3138 and explained in section [Section 12.2](#).

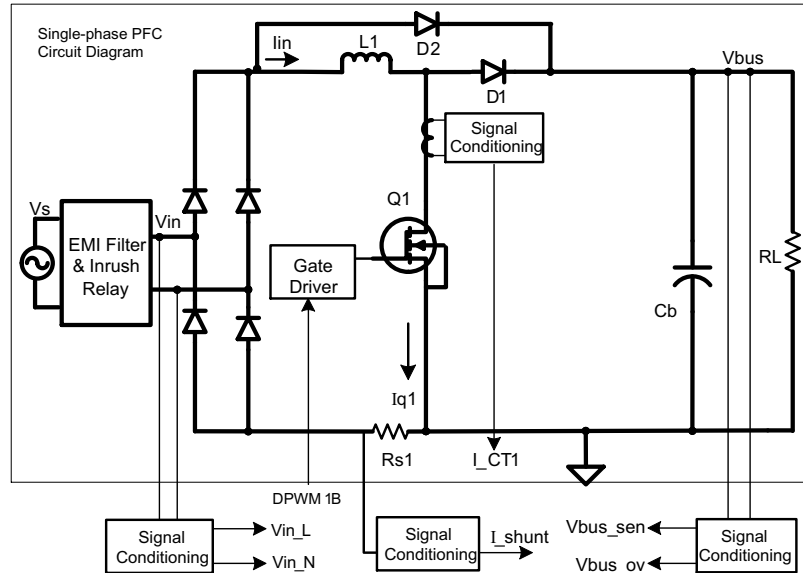

Figure 25. Digitally Controlled Single-Phase PFC System Block Diagram

12.1.2 2-Phase PFC Block Diagram

A functional block diagram of a 2-phase interleaved PFC is shown in Figure 26. The digital controlled 2-phase interleaved PFC has the same power stage seen in other analog controlled devices. All signals interact with UCD3138 and are explained in section 12.2.

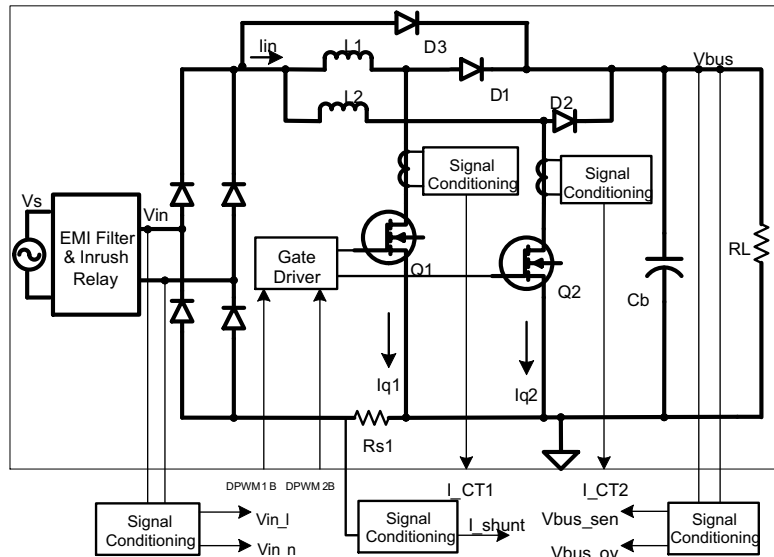

Figure 26. Digitally Controlled 2-Phase PFC System Block Diagram

12.1.3 Bridgeless PFC Block Diagram

A function block diagram of a bridgeless PFC is shown in Figure 27. The digital controlled bridgeless PFC has a same power stage as those seen in analog controlled. All signals interacted with UCD3138 are explained in the section Section 12.2.

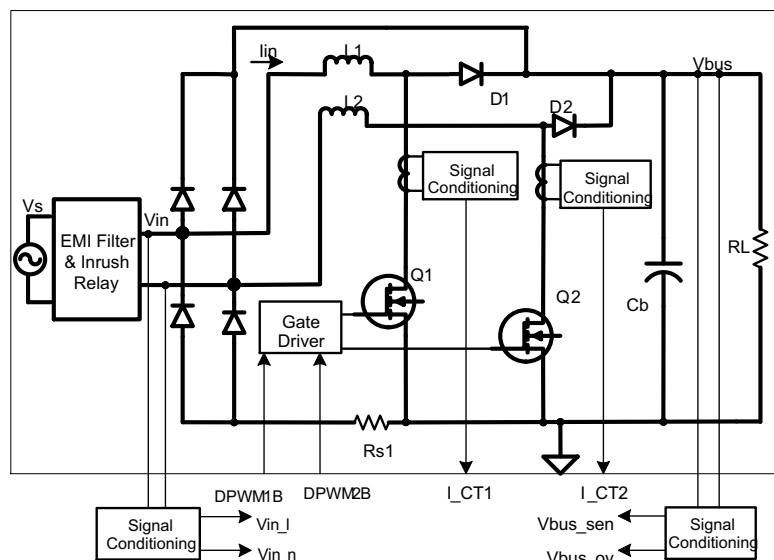

Figure 27. Digitally Controlled Bridgeless PFC System Block Diagram

12.2 UCD3138 Pin Definition

In this EVM, the PFC DC bus voltage feedback loop control is implemented using firmware execution by the ARM7 microcontroller, while the high-speed current loop control is implemented in the digital power peripherals in the UCD3138. The DC bus voltage, AC line and AC neutral voltages are sensed using the general purpose ADC in the ARM block. This is executed while the current signal is sensed and processed using the Front-End (EADC) block in the digital power peripherals. All protection functions such as cycle-by-cycle current limiting and overvoltage protection are implemented using the high-speed analog comparators available in the UCD3138.

12.2.1 UCD3138 Pin Definition in Single-Phase PFC

UCD3138 is a 64-pin device. When using the UCD3138 as a single-phase PFC controller, the pins used are defined in Figure 28.

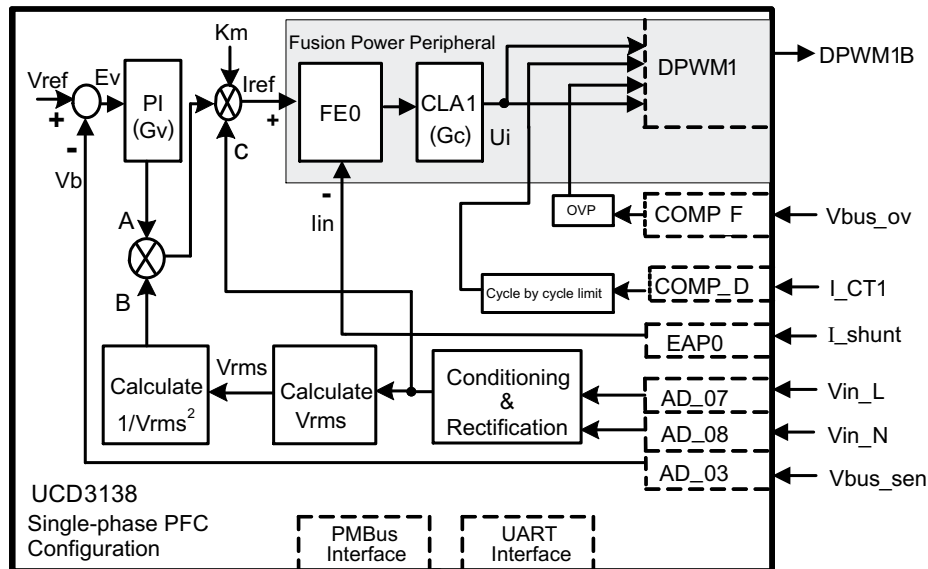

Figure 28. Definition of UCD3138 in Single-Phase PFC Control

12.2.2 UCD3138 Pin Definition in 2-Phase PFC

UCD3138 pin definition in 2-phase interleaved PFC control, shown in Figure 29.

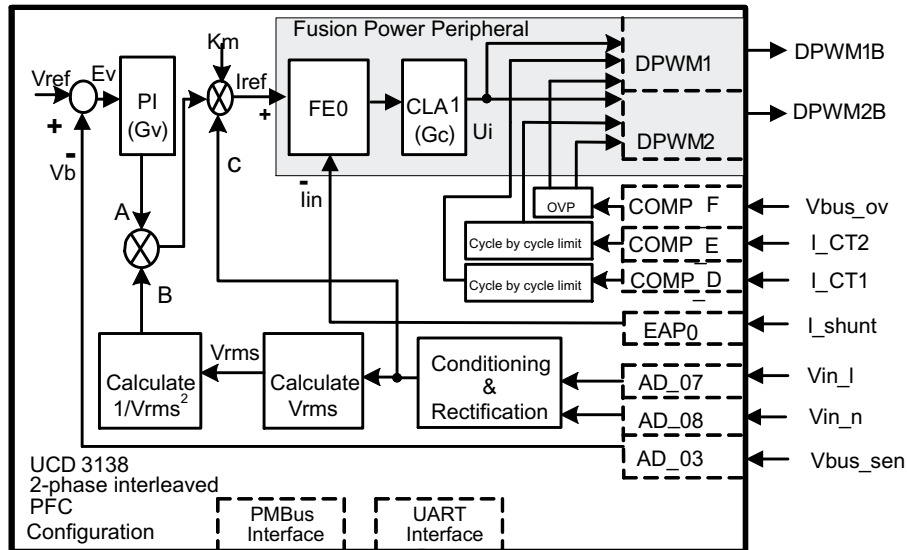

Figure 29. Definition of UCD3138 in 2-Phase PFC Control

12.2.3 UCD3138 Pin Definition in Bridgeless PFC

UCD3138 pin definition shown in bridgeless PFC control, see Figure 30.

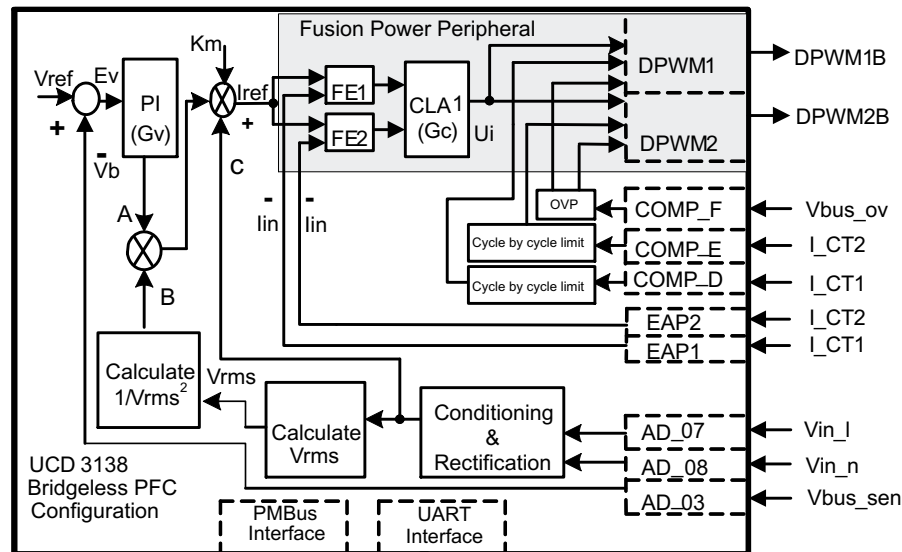

Figure 30. Definition of the UCD3138 in Bridgeless PFC Control

12.3 EVM Hardware – Introduction

12.3.1 PFC Pre-Regulator Input

The power entry section, PFC pre-regulator input, as shown in Figure 31, consists of EMI input filter, AC voltage sense circuit and inrush relay control circuit. The series resistor R3 limits the inrush current. The inrush control relay K1, controlled by the UCD3138 controller, is used to bypass this resistor. The controller measures input and output voltages and decides the appropriate time for closure of this relay. Input AC voltage is scaled and conditioned, and the sensed signal is applied to the UCD3138 ADC input AD_07 and AD_08. Figure 31 also shows a DC voltage regulator D3, which converts the 12 V into 3.3 V to provide the bias for on-board 3.3 V.

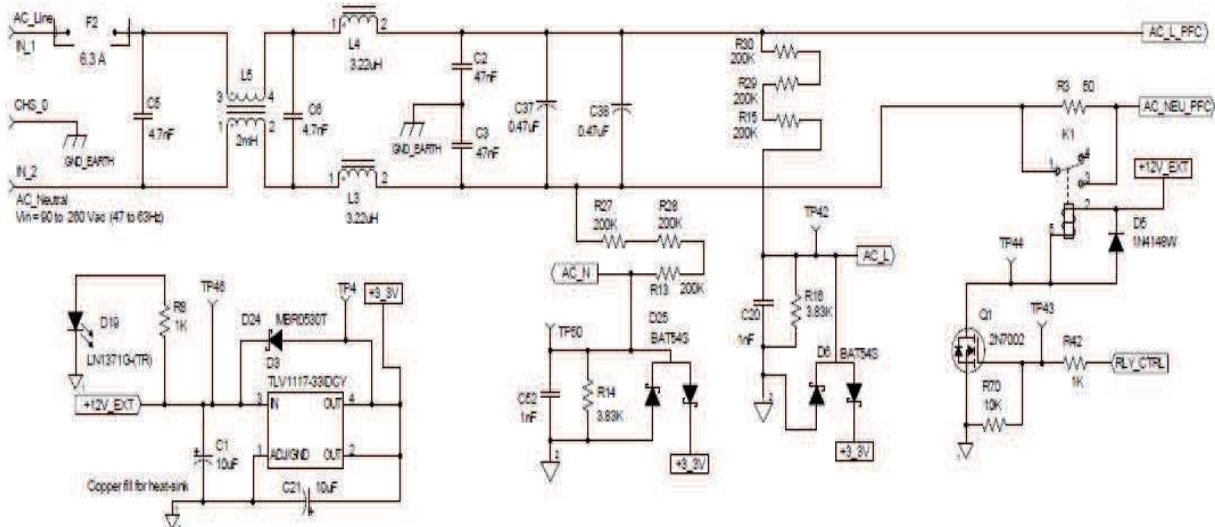

Figure 31. AC Power Filtering, Inrush Current Limit and AC Voltage Sense

12.3.2 PFC Power Stage

The PFC power stage shown in [Figure 32](#) employs a 2-phase boost PFC topology, even though the default configuration of the EVM is single phase PFC. The power MOSFETs, Q3 and Q4, are driven by the controller's DPWM signals, DPWM1B and DPWM2B, through UCC27324 MOSFET gate drive device. The schematic also shows that four additional signals are sensed and eventually connected to UCD3138 controller's 12-bit ADC input pins. These four signals are the rectified AC line and neutral voltage, the DC bus voltage for voltage loop control, redundant OVP protection and input current. The sensed signals are scaled and conditioned to a range of 0 V to 2.5 V which corresponds to the full scale range of the ADC.

For single-phase PFC and 2-phase interleaved PFC, the PFC stage total input current is differentially sensed across the sense resistors, R6 and R7, and then conditioned by the current sense amplifier U1. This is shown in [Figure 32](#). This sensed input current signal is scaled and conditioned to a range of 0 V to 1.6 V corresponding to the range of the on-chip DAC associated with the error ADC0 (EADC0).

In DCM mode, the inductor current oscillates between the inductor and switch node equivalent capacitor. As a result, the inductor current goes to negative, but the negative current will not show up at the output of the current amplifier. Therefore, the amplifier output does not represent the total inductor current. In order to sense this negative current, an offset is added to the amplifier's positive input terminal, this is shown as R113 in [Figure 32](#).

For bridgeless PFC, the PFC stage input current is sensed by current transformer T2 and T3. The output signal of T2 and T3 is rectified, scaled and conditioned to a range of 0 V to 1.6 V corresponding to the range of the on-chip DAC associated with the error ADC1 (EADC1) and error ADC2 (EADC2).

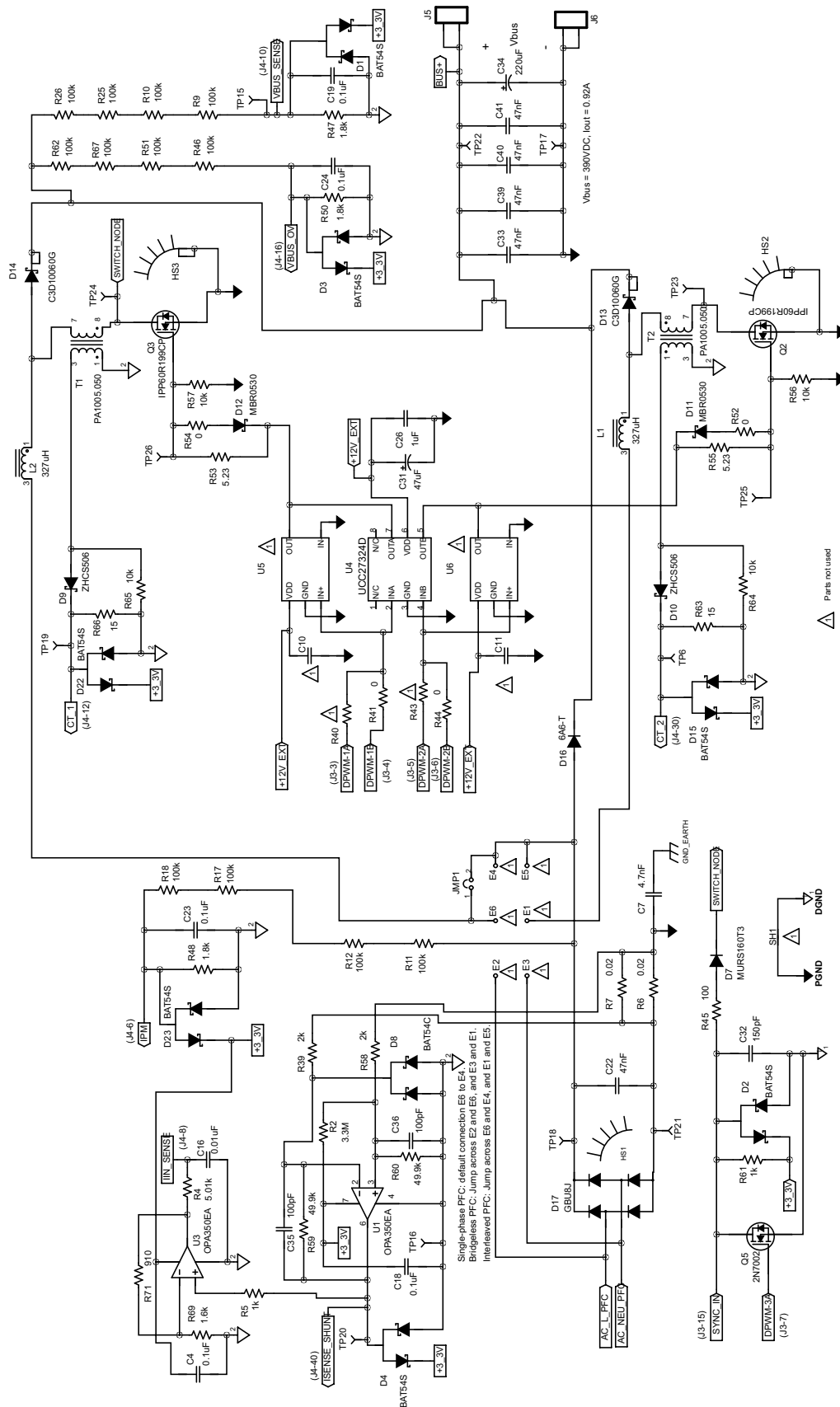

Figure 32. PFC Power Stage

12.3.3 Non-Isolated UART Interface

The non-isolated UART interface shown in Figure 33 is used to control the PFC module from the host PC over the serial port. It is also used to monitor some of the parameters, debug and test firmware functions.

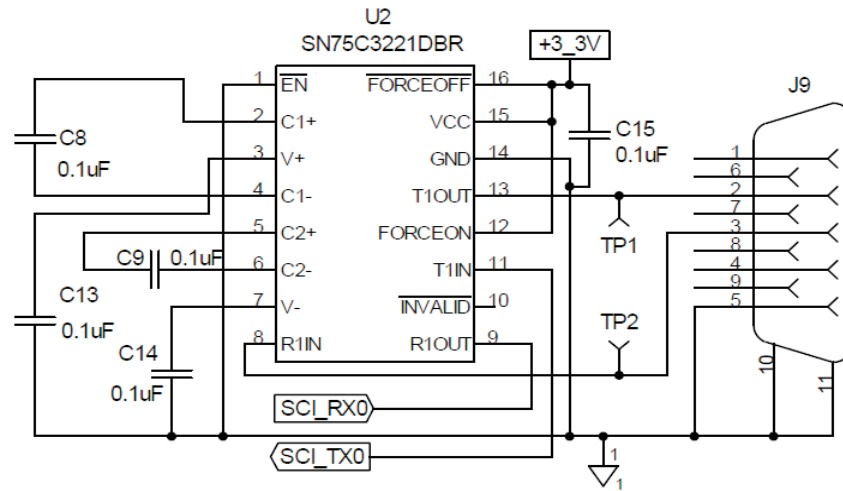

Figure 33. Non-Isolated PFC Module to Host PC Interface

12.3.4 Isolated UART Interface

The isolated UART interface shown in Figure 34 is used to communicate with another digital controller, for example one used in a secondary referenced isolated DC-to-DC converter application.

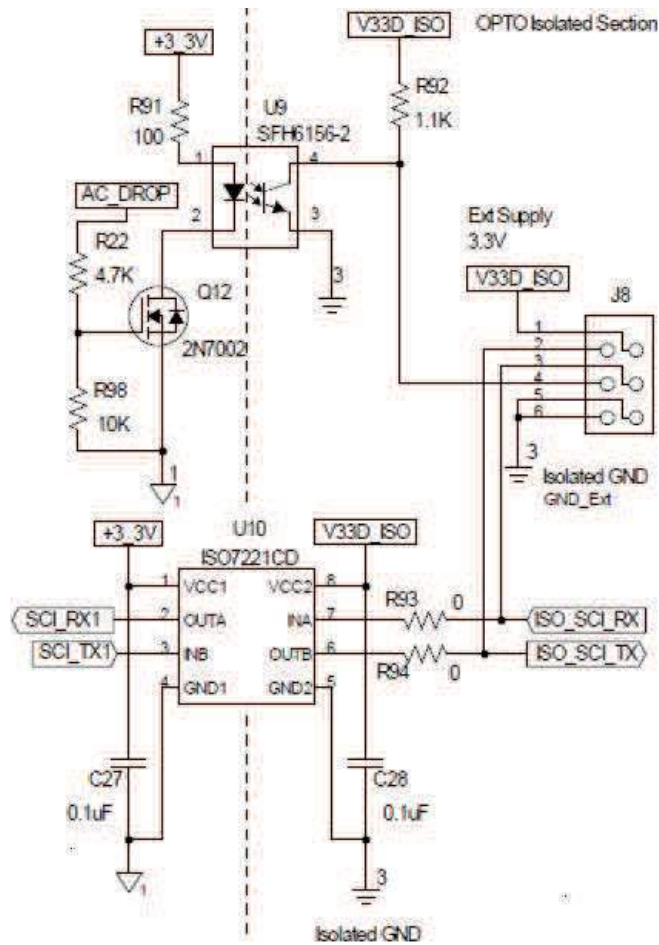

Figure 34. Isolated UART and AC_DROP Signal Interface

12.3.5 Interface Connector of Control Card

The interface connector between the PFC board and the UCD3138 controller board is shown in Figure 35.

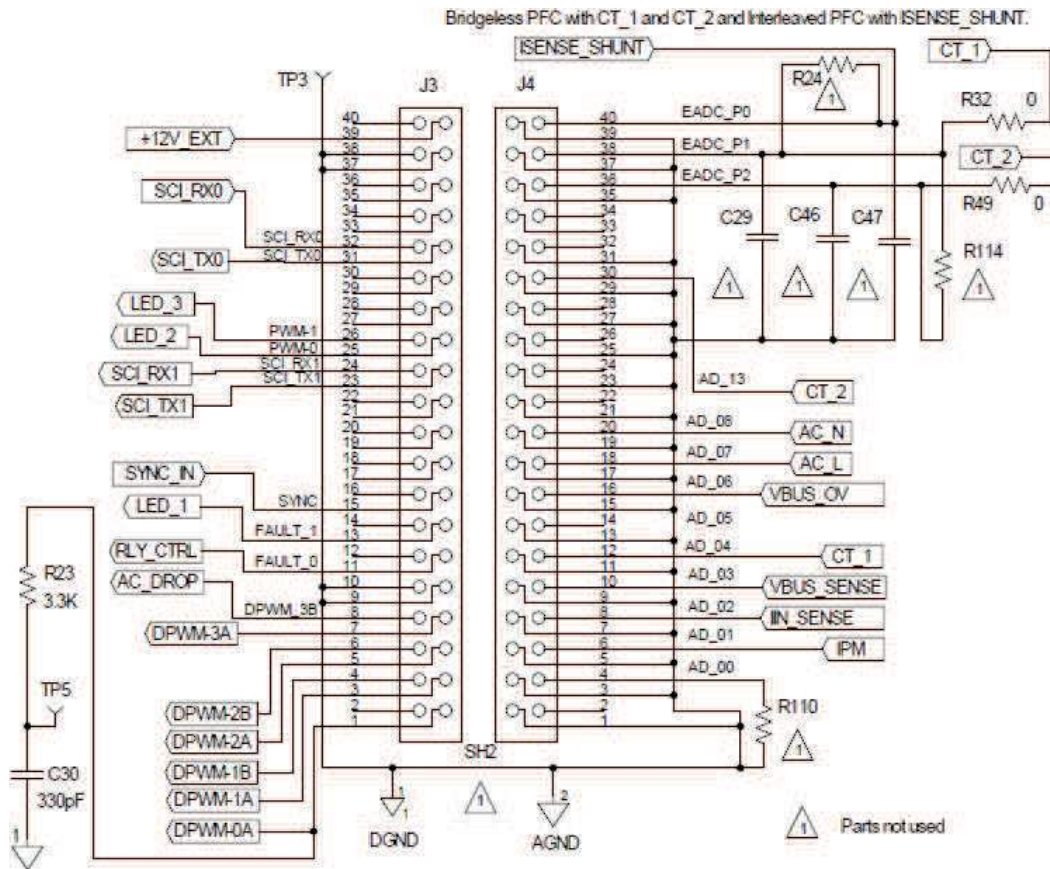

Figure 35. UCD3138 Controller Board and PFC Board Signal Interface Connector Diagram

12.3.6 UCD3138 Resource Allocation for PFC Control

Table 5. J3 and J4 Pin Assignment

HEADER PIN NUMBER	UCD3138 CONTROL CARD PIN NAME	DESCRIPTION
J3-1	DPWM_0A	RC filter for debug monitoring
J3-2	DPWM_0B	Not used
J3-3	DPWM_1A	Not used(available as an option for PFC PWM1)
J3-4	DPWM_1B	PFC PWM1
J3-5	DPWM_2A	Not used(available as an option for PFC PWM2)
J3-6	DPWM_2B	PFC PWM2
J3-7	DPWM_3A	PFC ZVS control
J3-8	DPWM_3B	AC drop indicator signal
J3-9	DGND	Digital ground GND1
J3-10	DGND	Digital ground GND1
J3-11	FAULT-0	Inrush relay control
J3-12	Not used	Not used
J3-13	FAULT-1	LED 1
J3-14	Not used	Not used
J3-15	SYNC	Sync input signal for PFC stage
J3-16	Not used	Not used
J3-17	FAULT-2	Not used
J3-18	Not used	Not used
J3-19	Not used	Not used
J3-20	Not used	Not used
J3-21	Not used	Not used
J3-22	FAULT-3	Not used
J3-23	SCI_TX1	SCI_TX1
J3-24	SCI_RX1	SCI_RX1
J3-25	PWM0	LED 2
J3-26	PWM1	LED 3
J3-27	Not used	Not used
J3-28	Not used	Not used
J3-29	TCAP	Not used
J3-30	Not used	Not used
J3-31	SCI TX0	SCI TX0
J3-32	SCI TX0	SCI RX0
J3-33	INT-EXT	Not used
J3-34	EXT-TRIG	Not used
J3-35	DGND	Not used
J3-36	RESET*	Not used
J3-37	DGND	Digital ground GND1
J3-38	DGND	Digital ground GND1
J3-39	+12V_EXT	External +12V DC supply
J3-40	3.3VD	Not used
J4-01	AGND	Analog ground GND2
J4-02	Not used	Not used
J4-03	AGND	Analog ground GND2
J4-04	AD_00	PMBus address
J4-05	AGND	Analog ground GND2

Table 5. J3 and J4 Pin Assignment (continued)

HEADER PIN NUMBER	UCD3138 CONTROL CARD PIN NAME	DESCRIPTION
J4-06	AD_01	IPM
J4-07	AGND	Analog ground GND2
J4-08	AD_02	PFC input current sense
J4-09	AGND	Analog ground GND2
J4-10	AD_03	PFC BUS voltage sense
J4-11	AGND	Analog ground GND2
J4-12	AD_04	PFC MOSFET Q3 current sense
J4-13	AGND	Analog ground GND2
J4-14	AD_05	Not used
J4-15	AGND	Analog ground GND2
J4-16	AD_06	PFC BUS voltage sense(for OVP)
J4-17	AGND	Analog ground GND2
J4-18	AD_07	PFC Vin line voltage sense
J4-19	AGND	Analog ground GND2
J4-20	AD_08	PFC Vin neutral voltage sense
J4-21	AGND	Analog ground GND2
J4-22	AD_09	Not used
J4-23	AGND	Analog ground GND2
J4-24	AD_10	Not used
J4-25	AGND	Analog ground GND2
J4-26	AD_11	Not used
J4-27	AGND	Analog ground GND2
J4-28	AD_12	Not used
J4-29	AGND	Analog ground GND2
J4-30	AD_13	PFC MOSFET Q4 current sense
J4-31	AGND	Analog ground GND2
J4-32	Not used	Not used
J4-33	Not used	Not used
J4-34	Not used	Not used
J4-35	EAN2	Analog ground GND2
J4-36	EAP2	PFC MOSFET Q4 current sense
J4-37	EAN1	Analog ground GND2
J4-38	EAP1	PFC MOSFET Q3 current sense
J4-39	EAN0	Analog ground GND2
J4-40	EAP0	PFC Input current sense

12.4 EVM Firmware – Introduction

The referenced firmware provided with the EVM is intended to demonstrate basic PFC functionality, as well as some basic PMBus communication and primary and secondary communication. A brief introduction to the firmware is provided in this section.

There are three timing levels in the current version of the firmware, as shown in [Figure 36](#):

1. Fast Interrupt (FIQ)
2. Standard Interrupt (IRQ)
3. Background

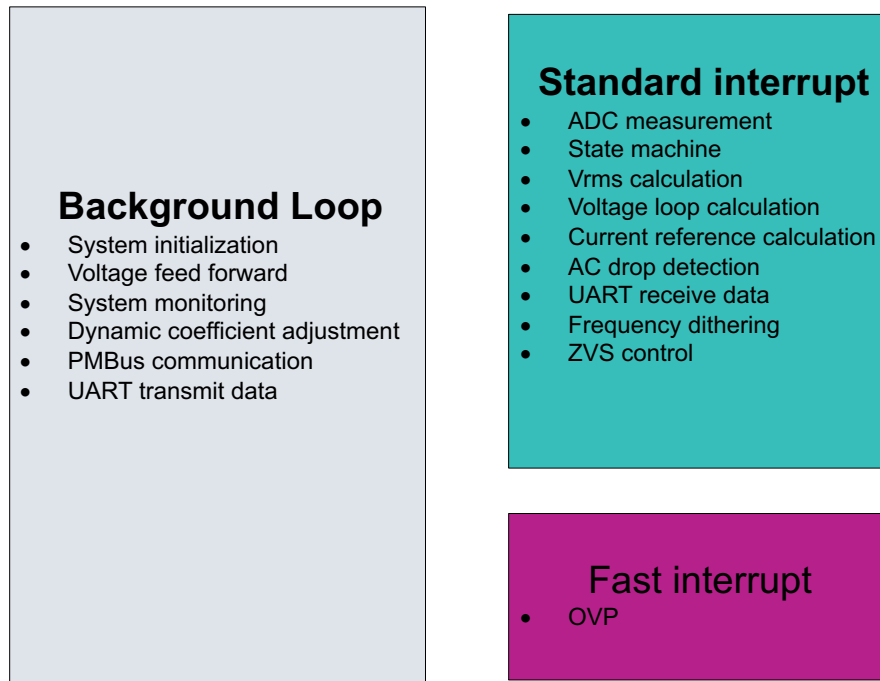

Figure 36. Firmware Structure Overview

Almost all firmware tasks occur during the standard interrupt. The only exceptions are the serial interface and PMBus tasks, which occur in the background, and the Over Voltage Protection (OVP), which is handled by the FIQ.

For more details, please refer to the source code and training material.

12.4.1 Background Loop

The firmware starts from function main(). In this function, after the system initialization, it goes to an infinite loop. All the non-time critical tasks are put in this loop, it includes:

- Calculate voltage feed forward.
- Clear current offset at zero load.
- System monitoring.
- PMBus communication.
- Primary and secondary UART communication.

NOTE: User can always add any non-time critical functions in this loop.

12.4.2 Voltage Loop Configuration

The voltage control loop is a pure firmware loop. V_{OUT} is sensed by a 12-bit ADC, and compared with voltage reference. The error goes into a firmware Proportional-Integral (PI) controller, and its output is used to do current loop reference calculations.

12.4.3 Current Loop Configuration

Current loop consists of several modules:

- Front End (FE) Module, to configure the AFE block gain.
 - For single phase PFC, AFE0 is used.
- Filter Module, to configure the current loop compensation.
 - FILTER1 is used.
- DPWM Module, to generate the PWM signal driving PFC.
 - For single phase PFC, DPWM1B is used.

NOTE: Loop Mux Module, to configure interconnection among front end, filter and DPWM modules.

12.4.4 Interrupts

There are two interrupts, the Standard Interrupt (IRQ), and the Fast Interrupt (FIQ).

- IRQ contains the state machine and most of the PFC control firmware.
- FIQ is used in relation to implementing OVP protections.

12.5 State Machine

The PFC hiccups once an over-voltage condition is detected. Only very serious over voltage causes PFC shut down and latch.

Figure 37 is the PFC state machine diagram shown below.

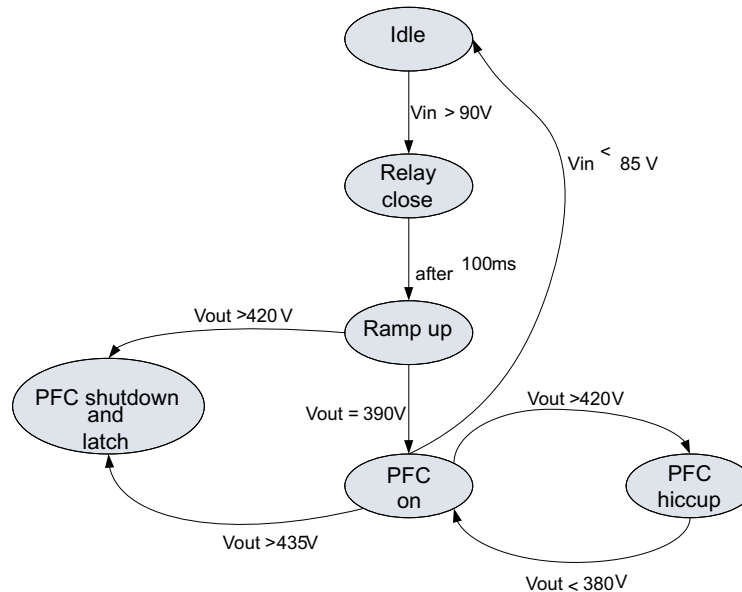

Figure 37. PFC State Machine

12.6 PFC Control Firmware

The PFC Control Firmware is almost all implemented in the IRQ function, which includes:

- ADC measurement
- State machine
- V_{RMS} calculation
- Voltage loop calculation
- Current reference calculation
- AC drop detection
- UART receive data
- Frequency dithering
- ZVS control

12.7 System Protection

12.7.1 Cycle-by-Cycle Current Protection (CBC)

The cycle-by-cycle current protection is achieved through AD04 (Comparator D) and AD13 (Comparator E). Once the current signal has exceeded the threshold, the PWM is chopped to limit the current.

12.7.2 Over-Voltage Protection (OVP)

There are two levels of OVP that exist. Under fault condition if the output voltage reaches 420 V, a non-latched OV protection is activated. Under this condition the output oscillates between 420 V and 380 V.

In the event of a more severe overvoltage condition, if the output reaches to 435 V, the latched over-voltage protection is activated and the unit is completely shut off.

The FIQ is currently used only for latched over-voltage protection. It is triggered by the comparator on AD06 (Comparator F). Comparator F's threshold is set above the limit for the DC bus voltage, and the logic on DPWM1 and DPWM2 is set up to turn off DPWM1B and DPWM2B when the threshold is exceeded. In the current configuration, the only way to restart the PFC after a latched OVP fault is to reset the processor.

12.8 PFC System Control

The system control block diagram is shown in [Figure 38](#). In steady state, the average current-mode control is used with switching frequency fixed at 100 kHz. At low line below 160 V_{AC} and light load, ZVS and valley control is used to reduce the switching losses and reduce total harmonic distortion.

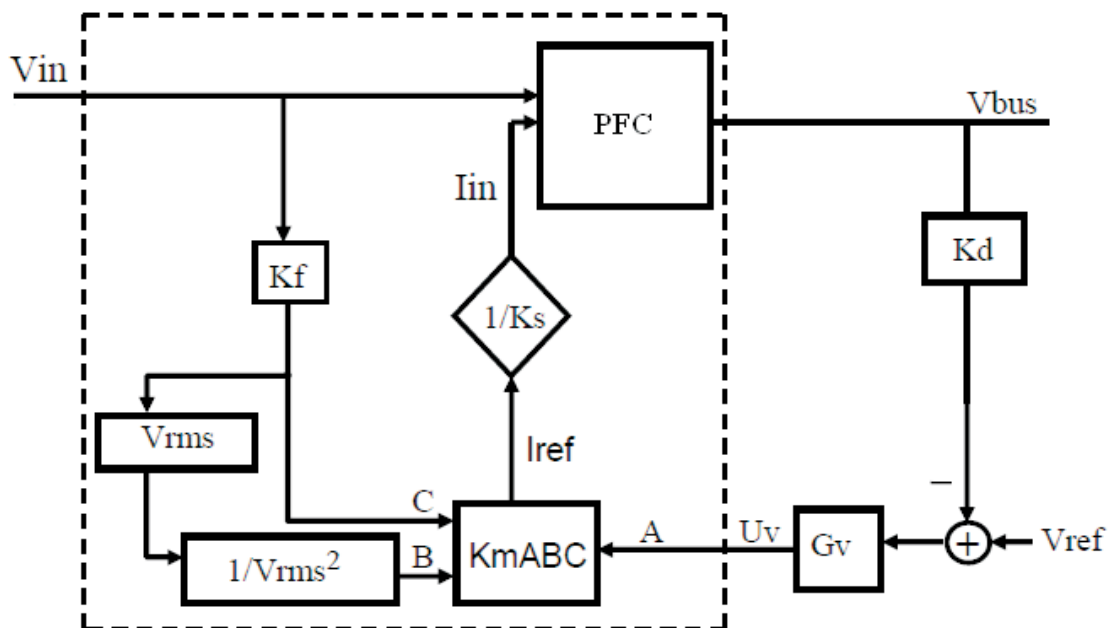

Figure 38. Single-Phase PFC System Control Diagram

12.8.1 Average Current Mode Control

The current loop is shown in the dashed line of Figure 38. The current reference signal I_{REF} is calculated as:

$$I_{REF} = K_m \times A \times C \times B = K_m \times (U_v) \times (K_f \times V_{IN}) \times \left(\frac{1}{V_{RMS}^2} \right)$$

where

- K_m – multiplier gain
- A – voltage loop output
- $B = 1/(V_{IN(rms)})^2$
- $C = V_{IN}$

(1)

For sine wave input, the multiplier gain K_m is expressed as,

$$K_m = 0.5 \times K_f \times V_{MIN(pk)}$$

(2)

In Figure 27, K_s and K_f are scaling factors. For further detail, please refer to reference , and .

12.8.2 ZVS and Valley Control

Please refer to the reference and .

12.9 Current Feedback Control Compensation Using PID Control

A functional block diagram of single-phase PFC control loop is shown in Figure 39.

PID control is usually used in the feedback loop compensation in digitally controlled power converters. Described below are several aspects using PID control in the single-phase PFC feedback control loop.

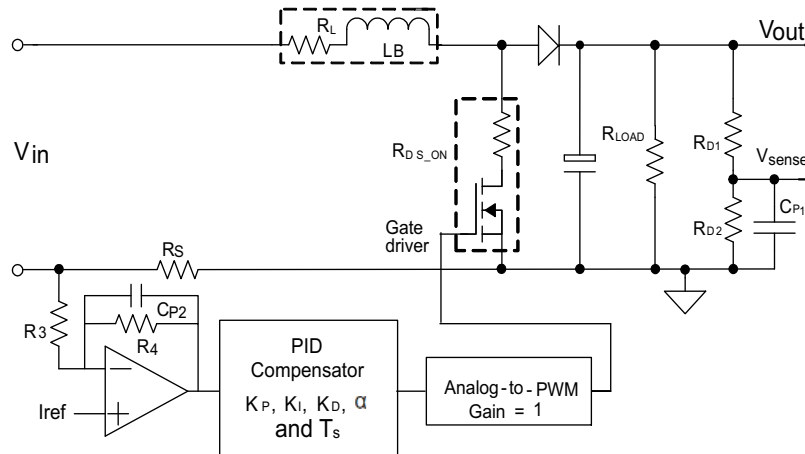

Figure 39. Single-phase PFC Feedback Loop Using PID Control

12.9.1 Loop Compensation from Poles and Zeros in s-Domain

PID control in the UCD3138 CLA for current control loop in single-phase PFC is formed in the following equation in z-domain:

$$G_c(z) = K_P + K_I \frac{1+z^{-1}}{1-z^{-1}} + K_D \frac{1-z^{-1}}{1-\alpha \times z^{-1}} \quad (3)$$

If Equation 3 is converted to the s-domain equivalent using the bilinear transform, the result has two forms. One is with two real zeros:

$$G_{cz}(s) = K_0 \frac{\left(\frac{s}{\omega_{z1}} + 1\right) \left(\frac{s}{\omega_{z2}} + 1\right)}{s \left(\frac{s}{\omega_{p1}} + 1\right)} \quad (4)$$

The two zeros can also be presented with complex conjugates and in such case,

$$G_{cz}(s) = K_0 \frac{\left(\frac{s^2}{\omega_r^2} + \frac{s}{Q \times \omega_r} + 1\right)}{s \left(\frac{s}{\omega_{p1}} + 1\right)} \quad (5)$$

Two complex conjugate zeros are expressed as:

$$\omega_{z1, z2} = \frac{\omega_r}{2 \times Q} \left(1 \pm \sqrt{1 - 4 \times Q^2}\right) \quad (6)$$

$$\omega_r = \sqrt{\omega_{z1} \times \omega_{z2}} \quad (7)$$

$$Q = \frac{\sqrt{\omega_{z1} \times \omega_{z2}}}{\omega_{z1} + \omega_{z2}} \quad (8)$$

The complex conjugate zeros become real zeros when:

$$Q \leq 0.5 \quad (9)$$

The sensing circuit in the current loop forms a low-pass filter and adds a pole to the loop:

$$\omega_{pcs} = \frac{1}{R_4 \times C_{p2}} \quad (10)$$

$$H_{cs}(s) = R_s \times \frac{R_4}{R_3} \frac{1}{\frac{s}{\omega_{pcs}} + 1} \quad (11)$$

The current closed-loop transfer function is then shown below:

$$G_{cs}(s) = \frac{G_M(s) \times G_{PID}(s)}{1 + G_M(s) \times G_{PID}(s) \times H_{cs}(s)}$$

where

- $G_M(s)$ is the transfer function of current loop before adding in PID. (12)

The parameters can be calculated with the assumption of current sensor sampling cycle T_s much smaller than the time constant of the PFC choke L_B and R_B , where L_B is the choke inductance and R_B is the choke DC resistance. Choose the sampling frequency to meet:

$$T_s = \frac{1}{f_s} \leq 0.05 \times \frac{L_B}{R_B} \quad (13)$$

When the above assumption is true, the delay effect from the sampling can be ignored and the parameters can be determined after we know where the poles and zeros should be positioned.

$$K_P = \frac{K_0 \times (\omega_{p1} \times \omega_{z1} + \omega_{p1} \times \omega_{z2} - \omega_{z1} \times \omega_{z2})}{\omega_{p1} \times \omega_{z1} \times \omega_{z2}} \quad (14)$$

$$K_I = \frac{K_0 \times T_s}{2} \quad (15)$$

$$K_D = \frac{2 \times K_0 \times (\omega_{p1} - \omega_{z1}) \times (\omega_{p1} - \omega_{z2})}{\omega_{p1} \times \omega_{z1} \times \omega_{z2} (T_s \times \omega_{p1} + 2)} \quad (16)$$

$$\alpha = \frac{2 - T_s \times \omega_{p1}}{2 + T_s \times \omega_{p1}} \quad (17)$$

12.9.2 Feedback Loop Compensation Tuning with PID Coefficients

When fine tuning the feedback control loop, one would like to know each parameter in PID how to affect the control loop characteristics without going through complicated description of the above equations. Table 6 below helps this and is visually shown in Figure 40.

Table 6. Tuning with PID Coefficients

Control Parameters	Impact on bode plot
KP	Increasing KP
•	Pushes up the minimum gain between the two zeros.
•	Moves the two zeros apart.
KI	Increasing KI
•	Pushes up integration curve at low frequencies.
•	Gives a higher low frequency gain.
•	Moves the first zero to the right.
KD	Increasing KD
•	Shifts the second zero left.
•	Does not impact the second pole.
α	Increasing α
•	Shifts the second pole to the right.
•	Shifts the second zero to the right.
$T_s = 1 / f_s$	Increasing the sampling frequency f_s :
•	Causes the whole Bode plot to shift to right.

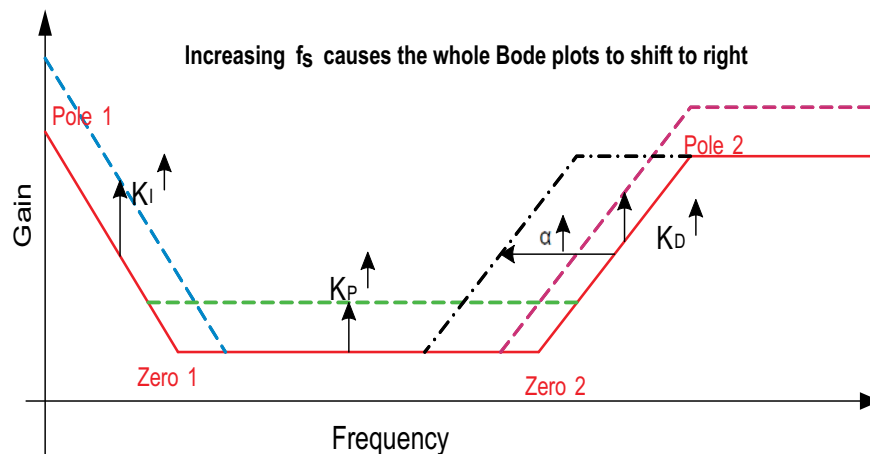

Figure 40. Tuning PID Parameters

12.9.3 Feedback Loop Compensation with Multiple-Set of Parameters

The digital control provides more flexibility to establish PID coefficients in multiple sets to adapt various operation conditions. For example, the single-phase PFC EVM has two sets of PID coefficients, set A is for low-line operation when the line voltage is between $90 V_{AC}$ and $160 V_{AC}$; while set B is for high-line operation when the line voltage is above $160 V_{AC}$ until $264 V_{AC}$.

12.10 Voltage Feedback Loop

The voltage feedback loop is a slow response loop with cross-over frequency is usually designed below 20 Hz to reduce the effect from AC line frequency. PI control is usually sufficient in this feedback loop control. During high-transient operation which causes large bulk-voltage deviation greater than certain values, for example, over 5%, digital control can adapt this high-transient requirement to use a different set of PI coefficients.

13 Evaluating the Single-Phase PFC with GUI

Further evaluation of UCD3138PFCEVM-026 can be made with the designer GUI while no need to directly access the firmware codes. The designer GUI, called Fusion Digital Power Designer is described in [Section 13.1](#). The description is given on how to use the GUI to make further evaluation of UCD3138PFCEVM-026.

13.1 Graphical User Interface (GUI)

Collectively, the GUI is called Texas Instruments Fusion Digital Power Designer. The GUI serves the interface for several families of TI digital control devices including the family of UCD31xx, that is the UCD3138 as its one member. The GUI can be divided into two main categories, Designer GUI and Device GUI. In the family of UCD31xx, each EVM is related to a particular Designer GUI to allow users to re-tune/re-configure a particular EVM in that regarding with existing hardware and firmware. Device GUI is related to a particular device to access its internal registers and memories.

UCD3138PFCEVM-026 is used with its control card UCD3138CC64EVM-030 where UCD3138 device is placed. The firmware for single-phase PFC control is loaded into UCD3138CC64EVM-030 board through device GUI. How to install the GUI is described in the user's guide *Using the UCD3138CC64EVM-030 (TI Literature Number, SLUU886)*. The designer GUI is installed at the same time when installing the device GUI.

13.2 Open the Designer GUI

To open the Designer GUI, click the start with the path as shown in [Figure 41](#).



Figure 41. Start the Designer GUI

13.3 Overview of the Designer GUI

When the designer GUI is open, it identifies the connected board by the ID in the firmware. Figure 42 shows the opened GUI. The Designer GUI provides various assistance to access the firmware codes indirectly. For the full set of the functions that the Designer GUI can provide, please refer to the user's manual. In this application note, we focus on how to make monitoring, board re-configuring and re-tuning to show basic aspects on how to use the GUI in a typical power supply design evaluation on a bench test.

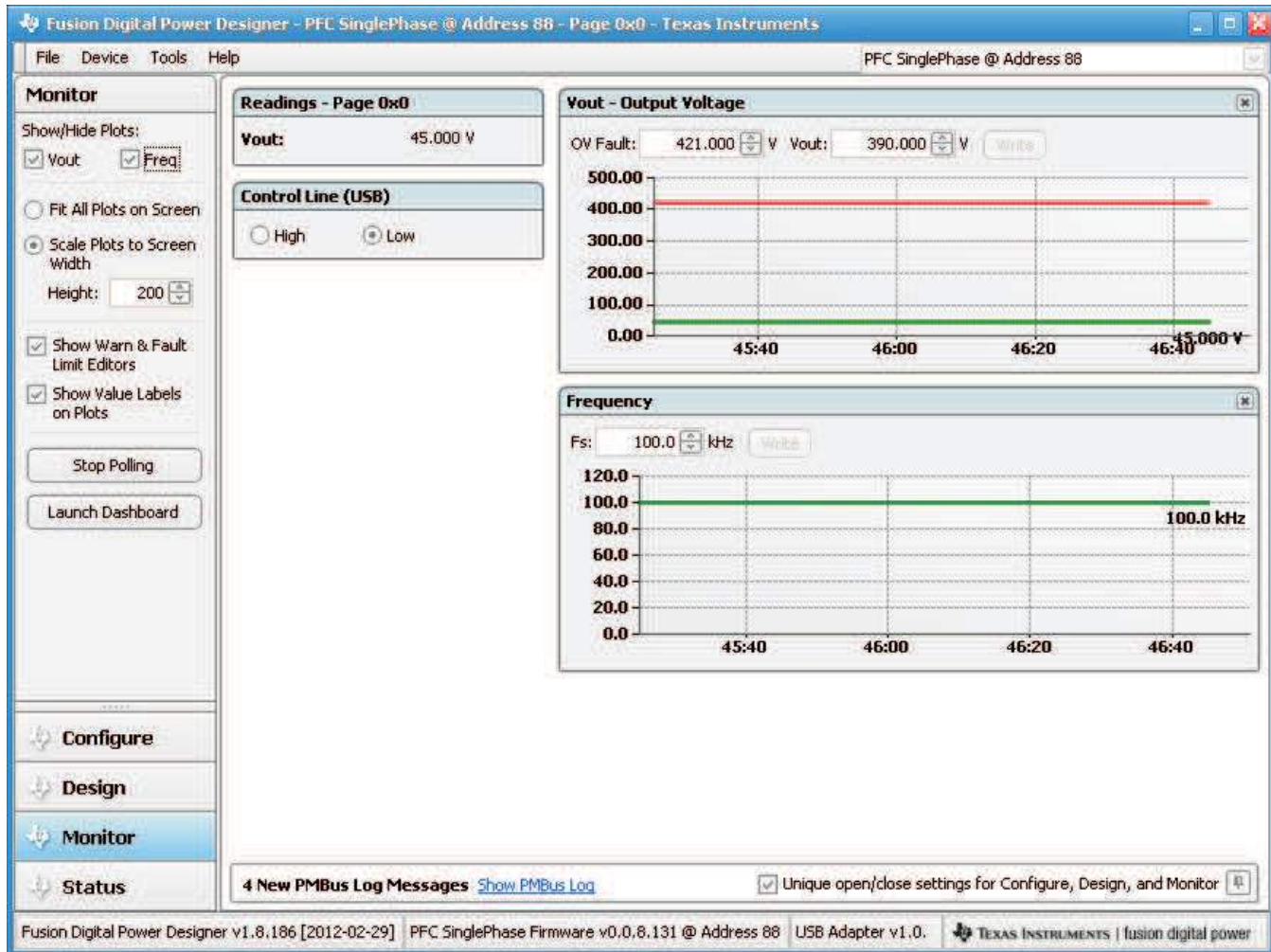

Figure 42. Designer GUI Overview

13.3.1 Monitor

On the lower left corner of that shown in Figure 42, there are four tabs, called *Configure*, *Design*, *Monitor* and *Status*. Clicking each tab brings a unique page to the front of that page. The clicked tab is highlighted in blue. Figure 42 shows *Monitor* tab was clicked. The page shows all variables in monitoring with UCD3138 single-phase PFC. These variables are communicated through PMBus. Adding more variables in *Monitoring* is possible but has to be executed through the firmware code change and re-compile process.

13.3.2 Status

When click tab *Status*, its corresponding page is shown in Figure 43. What can be seen is all entries are grayed out. This means nothing was designed to show from this tab. The page of *Status* provides all possible PMBus supported variables in communication. To activate these variables in communication, corresponding firmware codes need to be in place. As what can be seen is all in gray which means none of the variables is established in communication in this page.

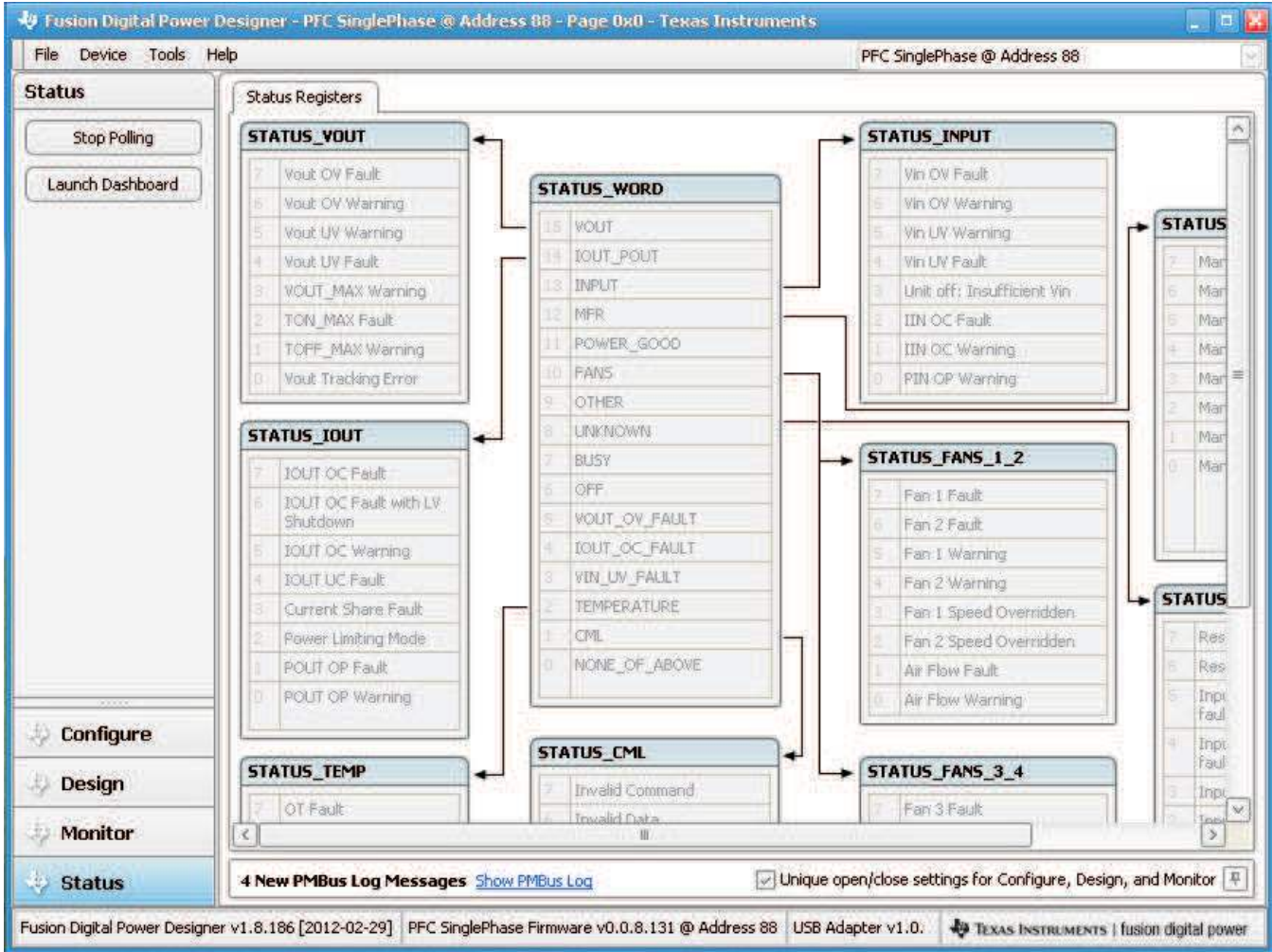

Figure 43. Page of *Status*

13.3.3 Design and Configure

If click *Design* or *Configure* two more different pages will be brought up to the front. These pages provide more functions and described in the following section.

14 Monitoring, Re-configuring and Re-tuning with Designer GUI

In this section, we describe how to use the Designer GUI to evaluate the single-phase PFC board, UCD3138PFCEVM-026

14.1 Power On and Test Procedure

Power stage connection is the same as described earlier. Additionally to that setup, PMBus connection is required through USB-to-GPIO as shown in [Figure 44](#).

After all connections are made, apply an AC source voltage with a specified value to the board AC input and refer to the other steps in the UCD3138PFCEVM-026 user's guide. Open and start the "Fusion Digital Power Designer" GUI following the steps described in [Section 13.2](#) and [Section 13.3](#). Once PFC pre-regulator is up and running and the GUI is opened, then it is ready to use the Designer GUI to make evaluation.

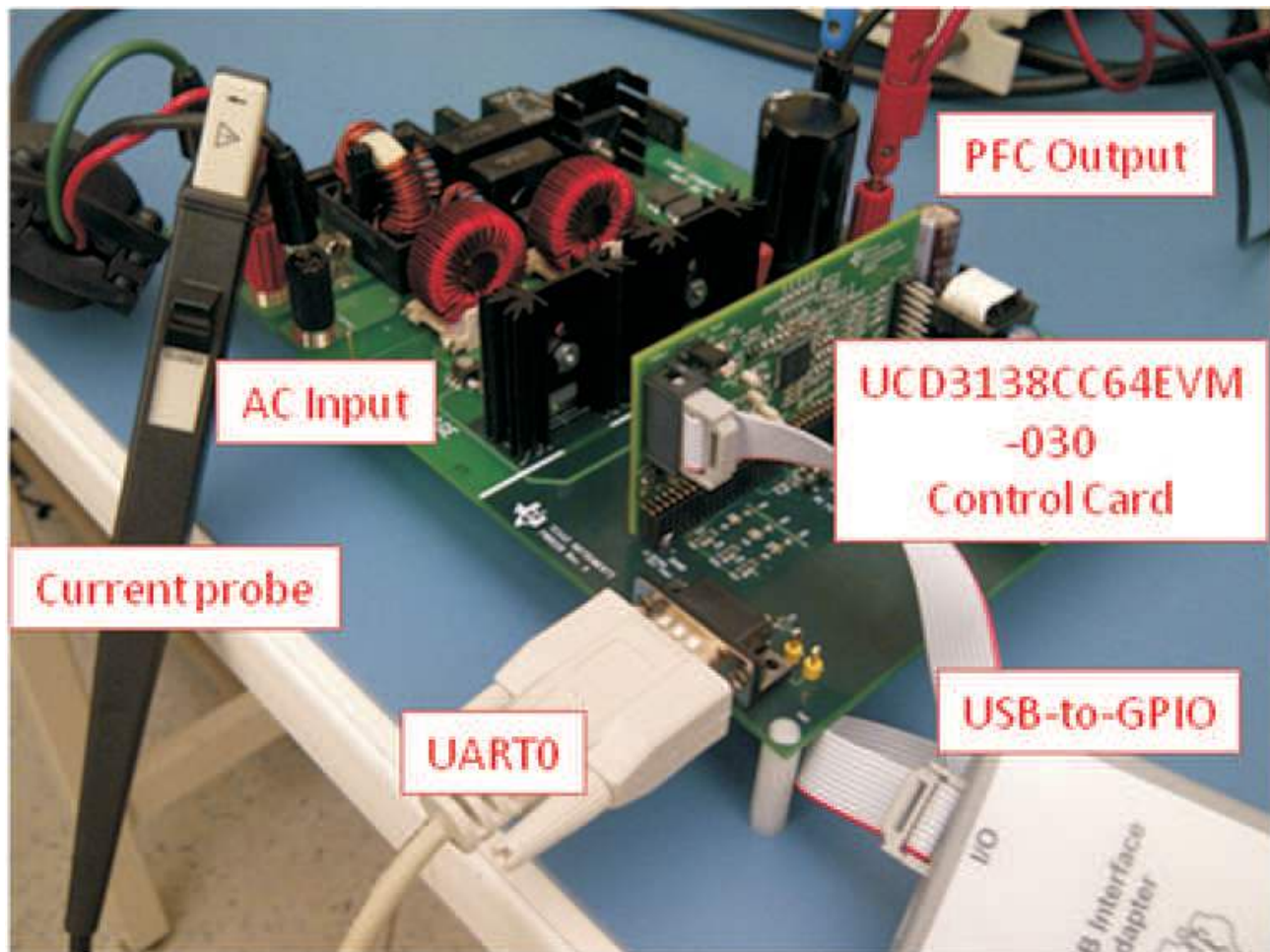

Figure 44. Hardware Setup for Evaluation with Designer GUI

14.2 Monitoring with GUI

The page shows three variables in monitoring:

- V_{OUT} – PFC output bulk voltage.
- OV Fault – PFC output bulk voltage over voltage fault threshold.
- Freq – switching frequency in normal operation.

Among three monitoring variables, we can see V_{OUT} and *OV Fault* can be accessed by *write* to change them to a different value into the firmware. However, when attempting to do so, make sure to understand the design of all aspects to avoid any possible damage. As a warning to help avoid damage, if one wants to modify “Vout” or “OV Fault” to a different value, the recommendation is 375 V to 395 V for V_{OUT} , and not exceeding 430 V for *OV Fault*. Also, logically, V_{OUT} has to be smaller than *OV Fault*.

One may modify them to other values but before doing that, fully understanding the design is needed to find out any other parameters needed to change accordingly such that not over stress the components in use or inducing any stability concerns.

14.3 Configuration and Re-configuring with GUI

After click the tab of “Configure”, the corresponding page called “Configuration” is shown as in Figure 45.

The variables shown in the page are the existing configuration. Most of them are fixed and can only be modified through firmware codes. One can designate which and how many variables can be re-configured in this page through firmware codes change. With the single-phase PFC board, there are three variables can be re-configured through this page without going through the firmware codes. As mentioned before, modify these variables to a different value requires fully understanding the design to avoid possible damage.

- V_{OUT} – PFC output bulk voltage
- OV Fault – PFC output bulk voltage over voltage fault threshold
- Freq – switching frequency in normal operation.

As mentioned earlier, the firmware version in use is shown in the page of “Configuration”. The firmware version is called DEVICE_ID. When place the mouse cursor on, the version indication is shown,

UCD3100ISO1 | 0.0.8.0129 | 111209

The firmware version or Device_ID is divided by two vertical lines. UCD3100ISO1 is the IC device family code. Between the two vertical lines, the show is the firmware recompilation indicator. The last six digits are date of the last time the recompilation was made.

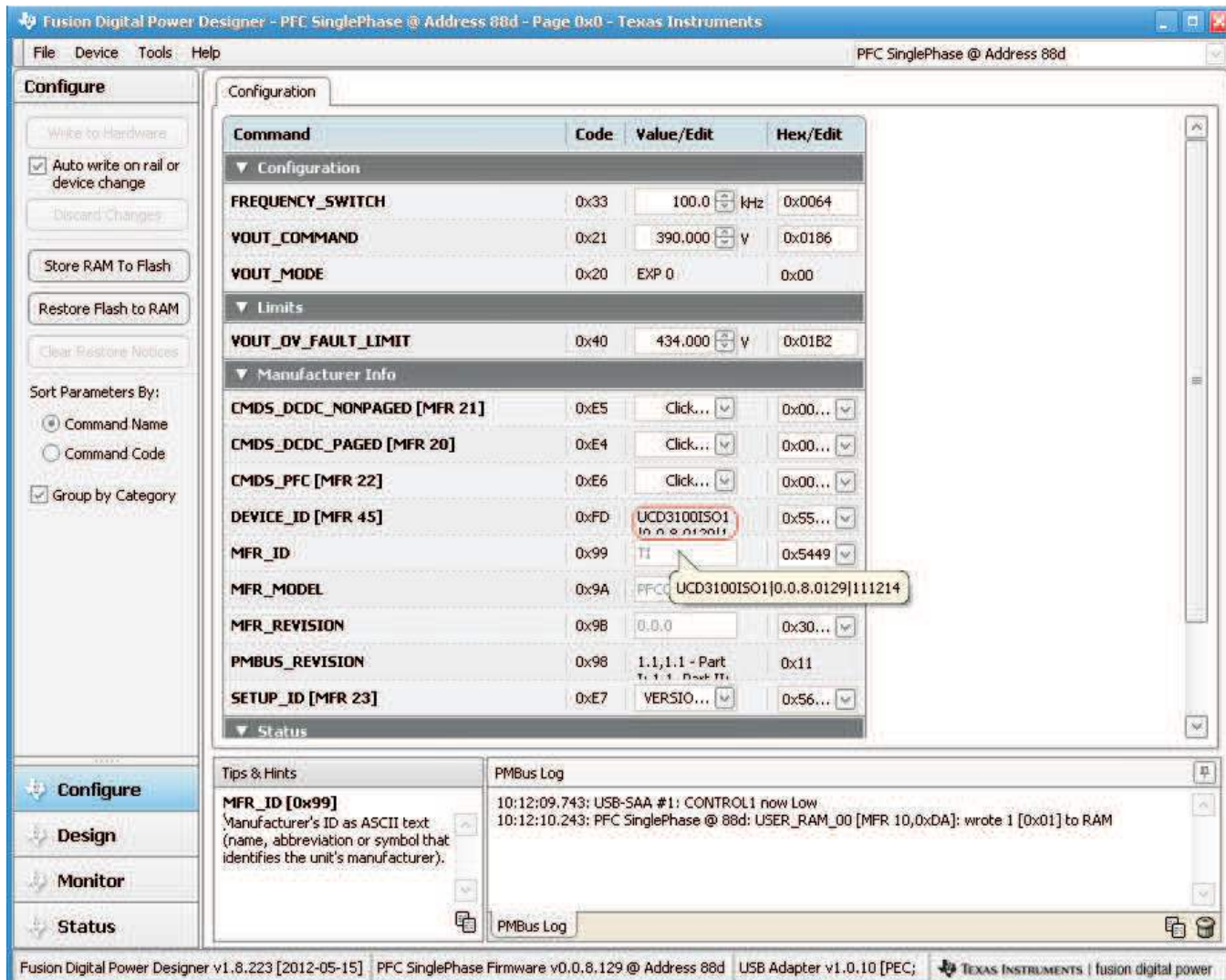

Command	Code	Value/Edit	Hex/Edit
Configuration			
FREQUENCY_SWITCH	0x33	100.0 kHz	0x0064
VOUT_COMMAND	0x21	390.000 V	0x0186
VOUT_MODE	0x20	EXP 0	0x00
Limits			
VOUT_OV_FAULT_LIMIT	0x40	434.000 V	0x01B2
Manufacturer Info			
CMDS_DCDC_NONPAGED [MFR 21]	0xE5	Click...	0x00...
CMDS_DCDC_PAGED [MFR 20]	0xE4	Click...	0x00...
CMDS_PFC [MFR 22]	0xE6	Click...	0x00...
DEVICE_ID [MFR 45]	0xFD	UCD3100ISO1 0.0.8.0129 111214	0x55...
MFR_ID	0x99	TI	0x5449
MFR_MODEL	0x9A	PFC UCD3100ISO1 0.0.8.0129 111214	
MFR_REVISION	0x9B	0.0.0	0x30...
PMBUS_REVISION	0x98	1.1,1.1 - Part	0x11
SETUP_ID [MFR 23]	0xE7	VERSIO...	0x56...
Status			

Tips & Hints

MFR_ID [0x99]
Manufacturer's ID as ASCII text (name, abbreviation or symbol that identifies the unit's manufacturer).

PMBus Log

```
10:12:09.743: USB-SAA #1: CONTROL1 now Low
10:12:10.243: PFC SinglePhase @ 88d: USER_RAM_00 [MFR 10,0xDA]: wrote 1 [0x01] to RAM
```

Fusion Digital Power Designer v1.8.223 [2012-05-15] PFC SinglePhase Firmware v0.0.8.129 @ Address 88d USB Adapter v1.0.10 [PEC; TEXAS INSTRUMENTS | fusion digital power

Figure 45. Page of Configuration

14.4 Feedback Control Loop Tuning and Re-Tuning with GUI

After click the tab of *Designer*, the page is shown as in Figure 46. In the UCD3138PFCEVM-026, this page is dedicated to the feedback loop design. This page including two sub-pages. One is for the current loop PID coefficients and the other is for the voltage feedback loop which uses PI control.

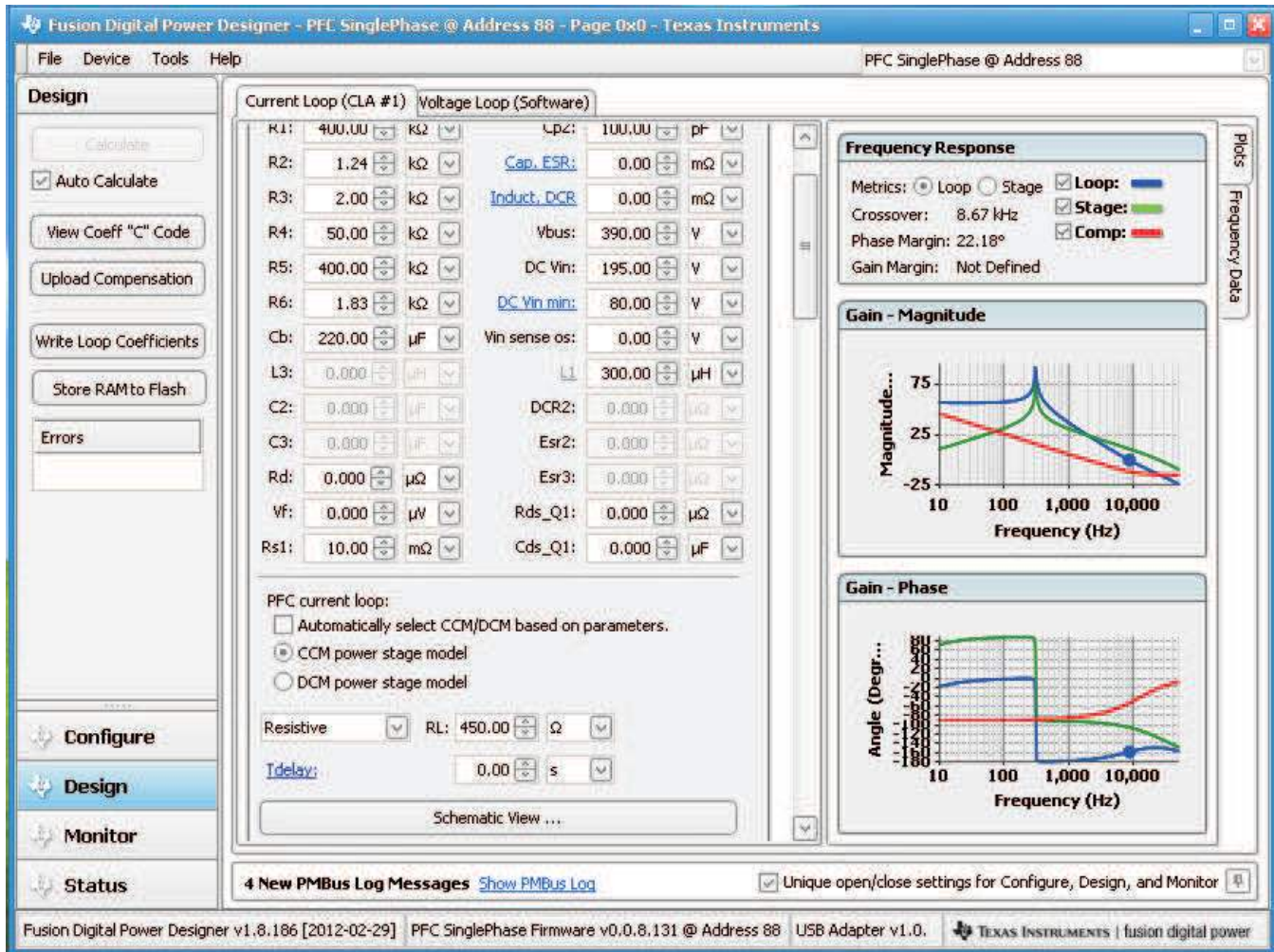

Figure 46. Page of *Designer*

14.4.1 Current Loop Evaluation

Figure 46 shows the current control loop. To evaluate the design or to re-tune the current loop PID coefficients, the first thing to do is to check all the parameters up to date in use. This can be done by clicking *Schematic View* to bring out a new window with the schematics shown in Figure 47. If any values are different from those in the physical circuitry, one needs to update them before doing any control loop re-tuning.

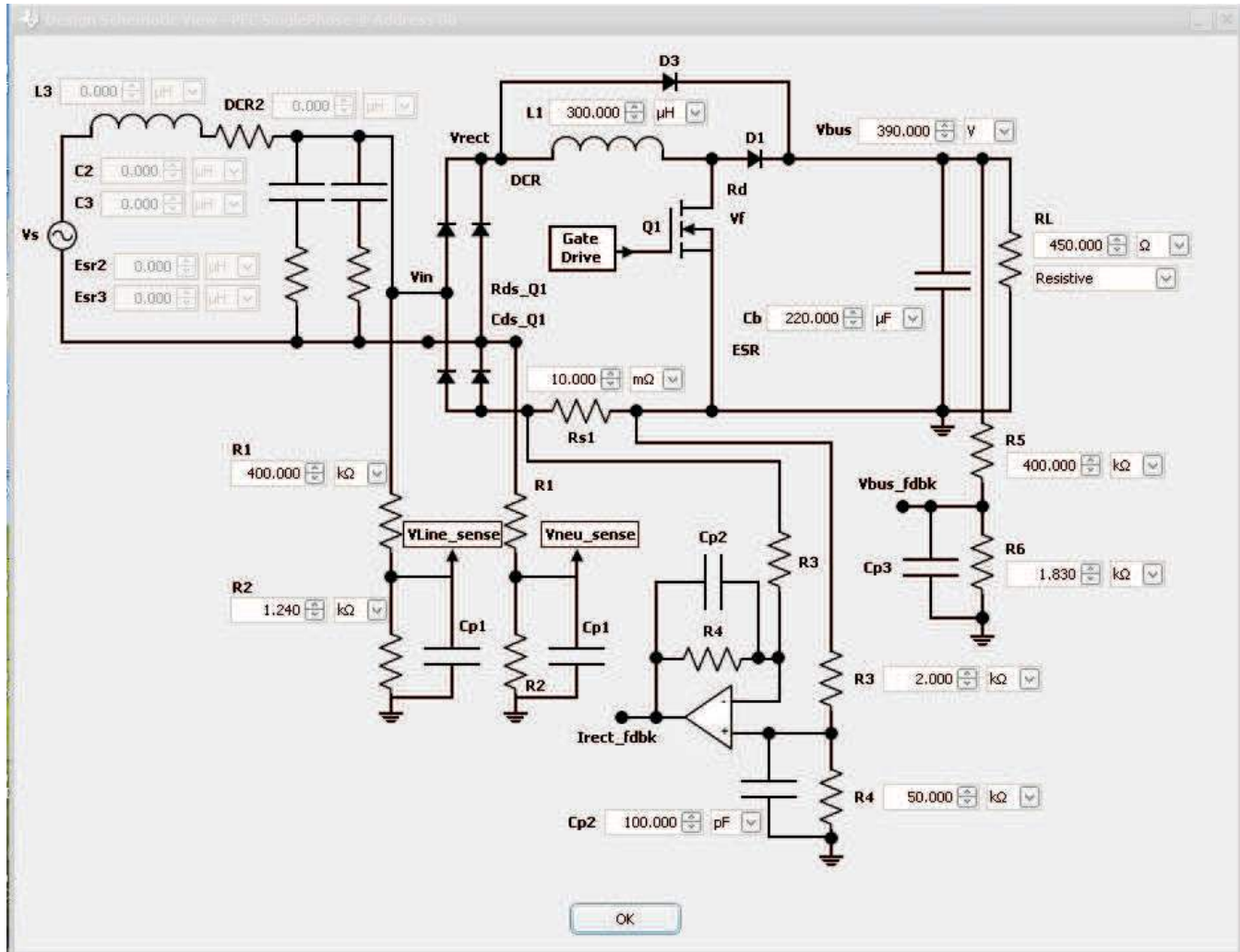

Figure 47. Schematics of Single-Phase PFC.

14.4.2 Current Loop Re-Tuning

The current loop PID coefficients can be re-tuned following the approaches described in section 1.4. Scroll down the window that is shown in Figure 46, then Figure 48 is obtained.

Figure 37 shows the current loop compensation details. There are two sets of PID coefficients used in the current control loop, Set A and Set B. In Figure 48 Set A is shown. The corresponding bode plots are shown on the right in Figure 48.

Coefficients of Set A are used when input line voltage is between 90 V_{AC} and 160 V_{AC}. Coefficients of Set B are used when input line voltage is above 160 V_{AC} till the maximum input of 264 V_{AC}.

The actual PID control makes re-scale of the values shown in Figure 48 when used inside the UCD3138.

$$G_{PID}(z) = \left(K_P + K_I \frac{1+z^{-1}}{1-z^{-1}} + K_D \frac{1-z^{-1}}{1-2^{-8} \times \alpha \times z^{-1}} \right) \times 2^{SC} \times K_{COMP} \times 2^{-19} \times \frac{1000}{2^4 \times (PRD + 1)} \quad (18)$$

PRD is a threshold value used to generate DPWM cycle ending point. The DPWM is centered on a period counter which counts up from 0 to PRD, and then is reset and starts over again. In the single-phase PFC design, K_{COMP} is set up equal to PRD.

In the current control page of the *Design*, PID coefficients can be re-tuned. The GUI also provides conversion results from PID coefficients to the zeros and the pole by clicking *Mode* to select a corresponding conversion. One can also change the zeros and the poles and then use the GUI to convert to PID coefficients by clicking *Mode* to select back to K_p, K_i, and K_d. Be aware that from the two zeros can be complex conjugates. When a set of PID coefficients does make complex conjugate zeros, the GUI pumps up a message to notify that Q and ω_r have to be generated instead of real zeros. In this case, the users may need to calculate the complex conjugate zeros based on Equation 6.

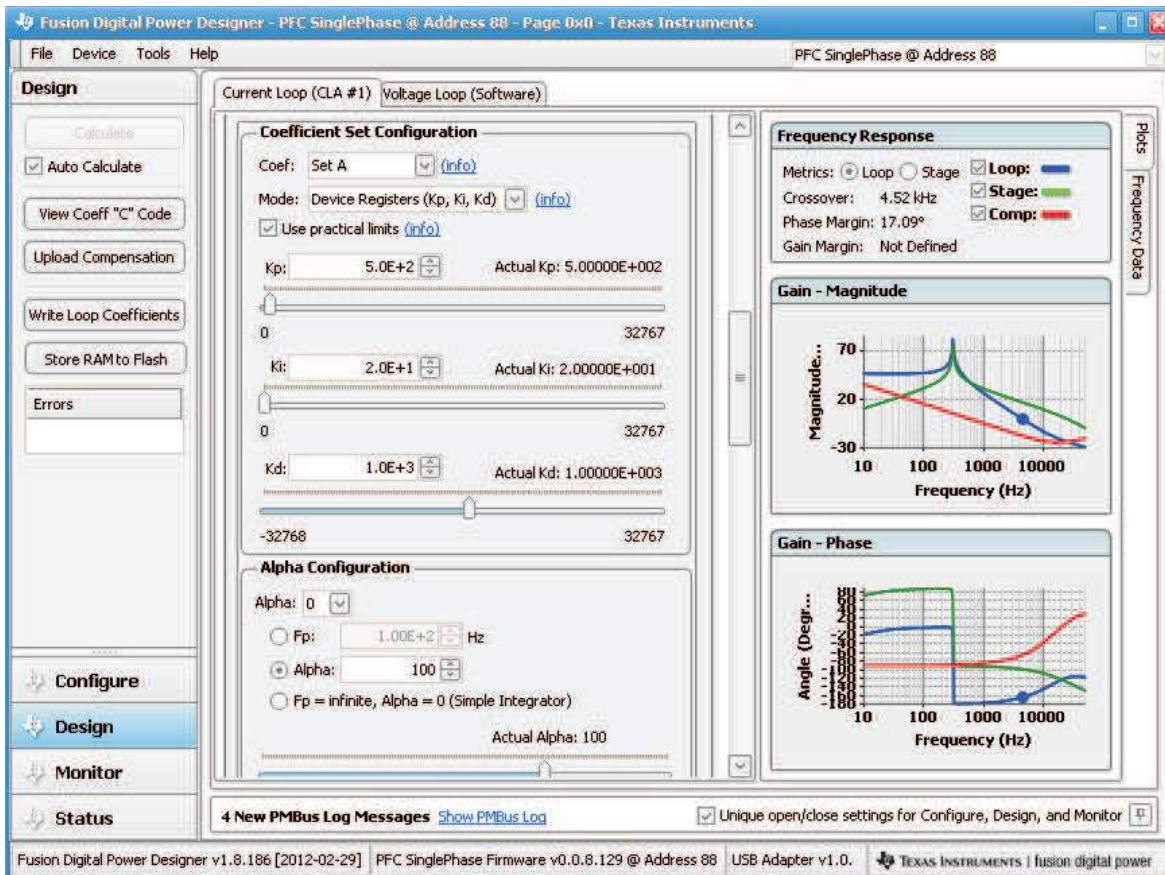

Figure 48. Current Loop Re-Tuning

14.4.3 Voltage Loop Evaluation and Re-tuning

Voltage loop can be evaluated and re-tuned in a similar way. Figure 49 shows voltage loop PI control coefficients and corresponding bode plots.

The voltage loop PI control is implemented with software and has the below form,

$$G_{PI}(z) = K_P + K_I \frac{1}{1 - z^{-1}} \quad (19)$$

There are two sets of the PI coefficients for voltage loop control. In normal operation, the control is with *Linear Coefficients*. In transient when the PFC output bulk voltage exceeds the defined *Error Threshold*, for example, 16.0 V, as shown, the PI control coefficients are changed to *Non-Linear Coefficients* to achieve better transient response and to eliminate the output large deviation faster. The output error threshold is usually within 5% of the output set point, or within 20 V on 390-V_{DC} output.

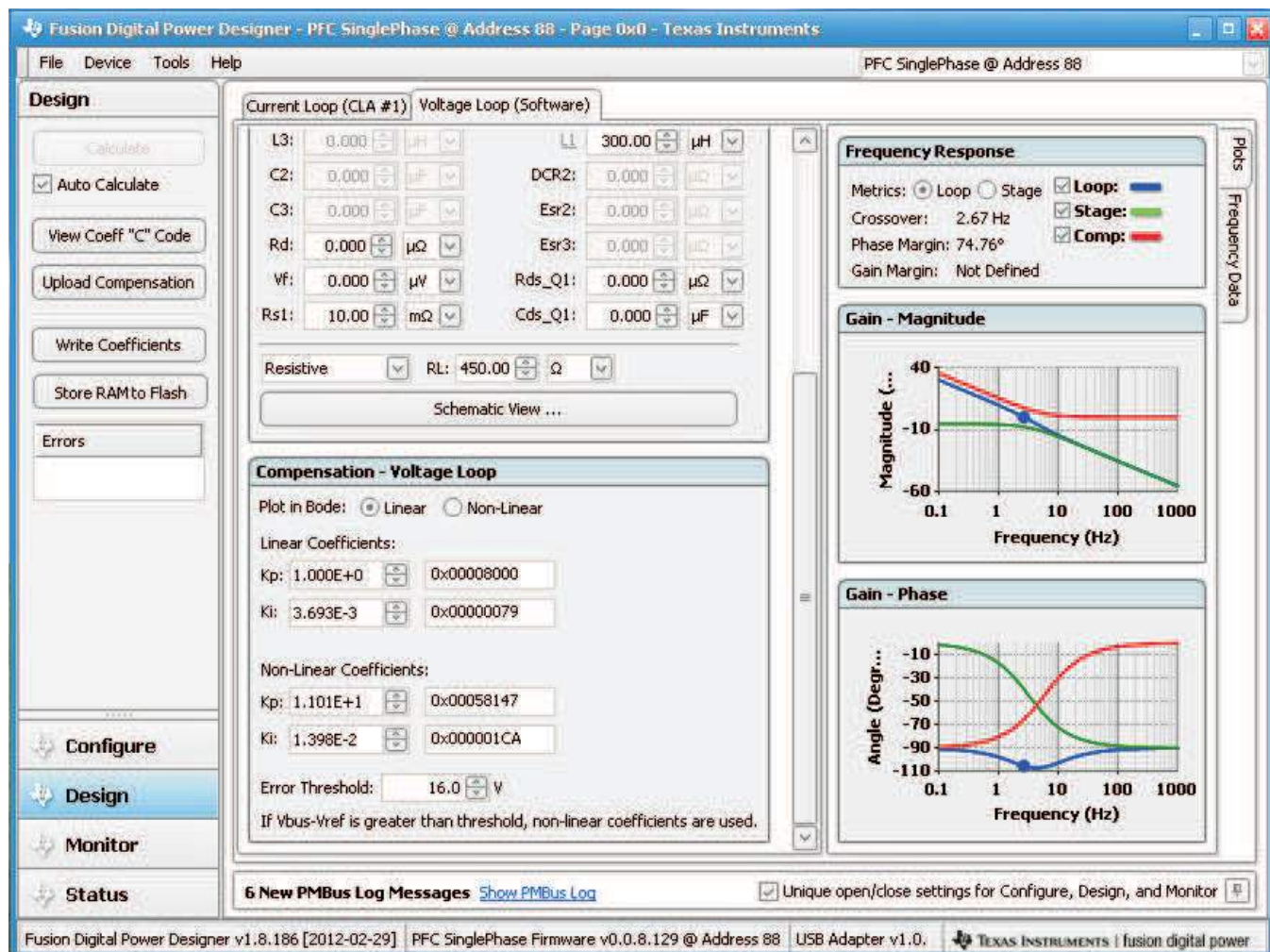

Figure 49. Voltage Loop PI Control Re-Tuning

15 Digital PFC Firmware Development

Please contact TI for additional information regarding UCD3138 digital PFC firmware development.

16 References

1. [UCD3138 Datasheet](#), SLUSAP2, 2012
2. [UCD3138CC64EVM-030 Evaluation Module and User's Guide](#), SLUU886, 2012
3. SEM600, 1988, High Power Factor Pre-regulator for Off-line Power Supplies
4. SEM700, 1990, Optimizing the Design of a High Power Factor Switching Pre-regulator
5. [TI Application Note SLUA644](#), "PFC THD Reduction and Efficiency Improvement by ZVS or Valley Switching", April 2012.
6. Zhong Ye and Bosheng Sun, "PFC Efficiency Improvement and THD Reduction at Light Loads with ZVS and Valley Switching", APEC 2012, pp 802-806
7. UCD3138 Digital Power Peripherals Programmer's Manual (please contact TI)
8. UCD3138 Monitoring and Communications Programmer's Manual (please contact TI)
9. UCD3138 ARM and Digital System Programmer's Manual (please contact TI)
10. UCD3138 Isolated Power Fusion GUI User Guide (please contact TI)

EVALUATION BOARD/KIT/MODULE (EVM) ADDITIONAL TERMS

Texas Instruments (TI) provides the enclosed Evaluation Board/Kit/Module (EVM) under the following conditions:

The user assumes all responsibility and liability for proper and safe handling of the goods. Further, the user indemnifies TI from all claims arising from the handling or use of the goods.

Should this evaluation board/kit not meet the specifications indicated in the User's Guide, the board/kit may be returned within 30 days from the date of delivery for a full refund. THE FOREGOING LIMITED WARRANTY IS THE EXCLUSIVE WARRANTY MADE BY SELLER TO BUYER AND IS IN LIEU OF ALL OTHER WARRANTIES, EXPRESSED, IMPLIED, OR STATUTORY, INCLUDING ANY WARRANTY OF MERCHANTABILITY OR FITNESS FOR ANY PARTICULAR PURPOSE. EXCEPT TO THE EXTENT OF THE INDEMNITY SET FORTH ABOVE, NEITHER PARTY SHALL BE LIABLE TO THE OTHER FOR ANY INDIRECT, SPECIAL, INCIDENTAL, OR CONSEQUENTIAL DAMAGES.

Please read the User's Guide and, specifically, the Warnings and Restrictions notice in the User's Guide prior to handling the product. This notice contains important safety information about temperatures and voltages. For additional information on TI's environmental and/or safety programs, please visit www.ti.com/esh or contact TI.

No license is granted under any patent right or other intellectual property right of TI covering or relating to any machine, process, or combination in which such TI products or services might be or are used. TI currently deals with a variety of customers for products, and therefore our arrangement with the user is not exclusive. TI assumes no liability for applications assistance, customer product design, software performance, or infringement of patents or services described herein.

REGULATORY COMPLIANCE INFORMATION

As noted in the EVM User's Guide and/or EVM itself, this EVM and/or accompanying hardware may or may not be subject to the Federal Communications Commission (FCC) and Industry Canada (IC) rules.

For EVMs **not** subject to the above rules, this evaluation board/kit/module is intended for use for ENGINEERING DEVELOPMENT, DEMONSTRATION OR EVALUATION PURPOSES ONLY and is not considered by TI to be a finished end product fit for general consumer use. It generates, uses, and can radiate radio frequency energy and has not been tested for compliance with the limits of computing devices pursuant to part 15 of FCC or ICES-003 rules, which are designed to provide reasonable protection against radio frequency interference. Operation of the equipment may cause interference with radio communications, in which case the user at his own expense will be required to take whatever measures may be required to correct this interference.

General Statement for EVMs including a radio

User Power/Frequency Use Obligations: This radio is intended for development/professional use only in legally allocated frequency and power limits. Any use of radio frequencies and/or power availability of this EVM and its development application(s) must comply with local laws governing radio spectrum allocation and power limits for this evaluation module. It is the user's sole responsibility to only operate this radio in legally acceptable frequency space and within legally mandated power limitations. Any exceptions to this are strictly prohibited and unauthorized by Texas Instruments unless user has obtained appropriate experimental/development licenses from local regulatory authorities, which is responsibility of user including its acceptable authorization.

For EVMs annotated as FCC – FEDERAL COMMUNICATIONS COMMISSION Part 15 Compliant

Caution

This device complies with part 15 of the FCC Rules. Operation is subject to the following two conditions: (1) This device may not cause harmful interference, and (2) this device must accept any interference received, including interference that may cause undesired operation.

Changes or modifications not expressly approved by the party responsible for compliance could void the user's authority to operate the equipment.

FCC Interference Statement for Class A EVM devices

This equipment has been tested and found to comply with the limits for a Class A digital device, pursuant to part 15 of the FCC Rules. These limits are designed to provide reasonable protection against harmful interference when the equipment is operated in a commercial environment. This equipment generates, uses, and can radiate radio frequency energy and, if not installed and used in accordance with the instruction manual, may cause harmful interference to radio communications. Operation of this equipment in a residential area is likely to cause harmful interference in which case the user will be required to correct the interference at his own expense.

FCC Interference Statement for Class B EVM devices

This equipment has been tested and found to comply with the limits for a Class B digital device, pursuant to part 15 of the FCC Rules. These limits are designed to provide reasonable protection against harmful interference in a residential installation. This equipment generates, uses and can radiate radio frequency energy and, if not installed and used in accordance with the instructions, may cause harmful interference to radio communications. However, there is no guarantee that interference will not occur in a particular installation. If this equipment does cause harmful interference to radio or television reception, which can be determined by turning the equipment off and on, the user is encouraged to try to correct the interference by one or more of the following measures:

- Reorient or relocate the receiving antenna.
- Increase the separation between the equipment and receiver.
- Connect the equipment into an outlet on a circuit different from that to which the receiver is connected.
- Consult the dealer or an experienced radio/TV technician for help.

For EVMs annotated as IC – INDUSTRY CANADA Compliant

This Class A or B digital apparatus complies with Canadian ICES-003.

Changes or modifications not expressly approved by the party responsible for compliance could void the user's authority to operate the equipment.

Concerning EVMs including radio transmitters

This device complies with Industry Canada licence-exempt RSS standard(s). Operation is subject to the following two conditions: (1) this device may not cause interference, and (2) this device must accept any interference, including interference that may cause undesired operation of the device.

Concerning EVMs including detachable antennas

Under Industry Canada regulations, this radio transmitter may only operate using an antenna of a type and maximum (or lesser) gain approved for the transmitter by Industry Canada. To reduce potential radio interference to other users, the antenna type and its gain should be so chosen that the equivalent isotropically radiated power (e.i.r.p.) is not more than that necessary for successful communication.

This radio transmitter has been approved by Industry Canada to operate with the antenna types listed in the user guide with the maximum permissible gain and required antenna impedance for each antenna type indicated. Antenna types not included in this list, having a gain greater than the maximum gain indicated for that type, are strictly prohibited for use with this device.

Cet appareil numérique de la classe A ou B est conforme à la norme NMB-003 du Canada.

Les changements ou les modifications pas expressément approuvés par la partie responsable de la conformité ont pu vider l'autorité de l'utilisateur pour actionner l'équipement.

Concernant les EVMs avec appareils radio

Le présent appareil est conforme aux CNR d'Industrie Canada applicables aux appareils radio exempts de licence. L'exploitation est autorisée aux deux conditions suivantes : (1) l'appareil ne doit pas produire de brouillage, et (2) l'utilisateur de l'appareil doit accepter tout brouillage radioélectrique subi, même si le brouillage est susceptible d'en compromettre le fonctionnement.

Concernant les EVMs avec antennes détachables

Conformément à la réglementation d'Industrie Canada, le présent émetteur radio peut fonctionner avec une antenne d'un type et d'un gain maximal (ou inférieur) approuvé pour l'émetteur par Industrie Canada. Dans le but de réduire les risques de brouillage radioélectrique à l'intention des autres utilisateurs, il faut choisir le type d'antenne et son gain de sorte que la puissance isotrope rayonnée équivalente (p.i.r.e.) ne dépasse pas l'intensité nécessaire à l'établissement d'une communication satisfaisante.

Le présent émetteur radio a été approuvé par Industrie Canada pour fonctionner avec les types d'antenne énumérés dans le manuel d'usage et ayant un gain admissible maximal et l'impédance requise pour chaque type d'antenne. Les types d'antenne non inclus dans cette liste, ou dont le gain est supérieur au gain maximal indiqué, sont strictement interdits pour l'exploitation de l'émetteur.

【Important Notice for Users of this Product in Japan】

This development kit is NOT certified as Confirming to Technical Regulations of Radio Law of Japan

If you use this product in Japan, you are required by Radio Law of Japan to follow the instructions below with respect to this product:

1. Use this product in a shielded room or any other test facility as defined in the notification #173 issued by Ministry of Internal Affairs and Communications on March 28, 2006, based on Sub-section 1.1 of Article 6 of the Ministry's Rule for Enforcement of Radio Law of Japan,
2. Use this product only after you obtained the license of Test Radio Station as provided in Radio Law of Japan with respect to this product, or
3. Use of this product only after you obtained the Technical Regulations Conformity Certification as provided in Radio Law of Japan with respect to this product. Also, please do not transfer this product, unless you give the same notice above to the transferee. Please note that if you could not follow the instructions above, you will be subject to penalties of Radio Law of Japan.

Texas Instruments Japan Limited
(address) 24-1, Nishi-Shinjuku 6 chome, Shinjuku-ku, Tokyo, Japan

<http://www.tij.co.jp>

【ご使用にあたっての注】

本開発キットは技術基準適合証明を受けておりません。

本製品のご使用に際しては、電波法遵守のため、以下のいずれかの措置を取っていただく必要がありますのでご注意ください。

1. 電波法施行規則第6条第1項第1号に基づく平成18年3月28日総務省告示第173号で定められた電波暗室等の試験設備でご使用いただく。
2. 実験局の免許を取得後ご使用いただく。
3. 技術基準適合証明を取得後ご使用いただく。

なお、本製品は、上記の「ご使用にあたっての注意」を譲渡先、移転先に通知しない限り、譲渡、移転できないものとします。

上記を遵守頂けない場合は、電波法の罰則が適用される可能性があることをご留意ください。

日本テキサス・インスツルメンツ株式会社
東京都新宿区西新宿6丁目24番1号
西新宿三井ビル

<http://www.tij.co.jp>

EVALUATION BOARD/KIT/MODULE (EVM) WARNINGS, RESTRICTIONS AND DISCLAIMERS

For Feasibility Evaluation Only, in Laboratory/Development Environments. Unless otherwise indicated, this EVM is not a finished electrical equipment and not intended for consumer use. It is intended solely for use for preliminary feasibility evaluation in laboratory/development environments by technically qualified electronics experts who are familiar with the dangers and application risks associated with handling electrical mechanical components, systems and subsystems. It should not be used as all or part of a finished end product.

Your Sole Responsibility and Risk. You acknowledge, represent and agree that:

1. You have unique knowledge concerning Federal, State and local regulatory requirements (including but not limited to Food and Drug Administration regulations, if applicable) which relate to your products and which relate to your use (and/or that of your employees, affiliates, contractors or designees) of the EVM for evaluation, testing and other purposes.
2. You have full and exclusive responsibility to assure the safety and compliance of your products with all such laws and other applicable regulatory requirements, and also to assure the safety of any activities to be conducted by you and/or your employees, affiliates, contractors or designees, using the EVM. Further, you are responsible to assure that any interfaces (electronic and/or mechanical) between the EVM and any human body are designed with suitable isolation and means to safely limit accessible leakage currents to minimize the risk of electrical shock hazard.
3. You will employ reasonable safeguards to ensure that your use of the EVM will not result in any property damage, injury or death, even if the EVM should fail to perform as described or expected.
4. You will take care of proper disposal and recycling of the EVM's electronic components and packing materials.

Certain Instructions. It is important to operate this EVM within TI's recommended specifications and environmental considerations per the user guidelines. Exceeding the specified EVM ratings (including but not limited to input and output voltage, current, power, and environmental ranges) may cause property damage, personal injury or death. If there are questions concerning these ratings please contact a TI field representative prior to connecting interface electronics including input power and intended loads. Any loads applied outside of the specified output range may result in unintended and/or inaccurate operation and/or possible permanent damage to the EVM and/or interface electronics. Please consult the EVM User's Guide prior to connecting any load to the EVM output. If there is uncertainty as to the load specification, please contact a TI field representative. During normal operation, some circuit components may have case temperatures greater than 60°C as long as the input and output are maintained at a normal ambient operating temperature. These components include but are not limited to linear regulators, switching transistors, pass transistors, and current sense resistors which can be identified using the EVM schematic located in the EVM User's Guide. When placing measurement probes near these devices during normal operation, please be aware that these devices may be very warm to the touch. As with all electronic evaluation tools, only qualified personnel knowledgeable in electronic measurement and diagnostics normally found in development environments should use these EVMs.

Agreement to Defend, Indemnify and Hold Harmless. You agree to defend, indemnify and hold TI, its licensors and their representatives harmless from and against any and all claims, damages, losses, expenses, costs and liabilities (collectively, "Claims") arising out of or in connection with any use of the EVM that is not in accordance with the terms of the agreement. This obligation shall apply whether Claims arise under law of tort or contract or any other legal theory, and even if the EVM fails to perform as described or expected.

Safety-Critical or Life-Critical Applications. If you intend to evaluate the components for possible use in safety critical applications (such as life support) where a failure of the TI product would reasonably be expected to cause severe personal injury or death, such as devices which are classified as FDA Class III or similar classification, then you must specifically notify TI of such intent and enter into a separate Assurance and Indemnity Agreement.

Mailing Address: Texas Instruments, Post Office Box 655303, Dallas, Texas 75265
Copyright © 2012, Texas Instruments Incorporated

STANDARD TERMS AND CONDITIONS FOR EVALUATION MODULES

1. *Delivery:* TI delivers TI evaluation boards, kits, or modules, including any accompanying demonstration software, components, or documentation (collectively, an "EVM" or "EVMs") to the User ("User") in accordance with the terms and conditions set forth herein. Acceptance of the EVM is expressly subject to the following terms and conditions.
 - 1.1 EVMs are intended solely for product or software developers for use in a research and development setting to facilitate feasibility evaluation, experimentation, or scientific analysis of TI semiconductors products. EVMs have no direct function and are not finished products. EVMs shall not be directly or indirectly assembled as a part or subassembly in any finished product. For clarification, any software or software tools provided with the EVM ("Software") shall not be subject to the terms and conditions set forth herein but rather shall be subject to the applicable terms and conditions that accompany such Software
 - 1.2 EVMs are not intended for consumer or household use. EVMs may not be sold, sublicensed, leased, rented, loaned, assigned, or otherwise distributed for commercial purposes by Users, in whole or in part, or used in any finished product or production system.
2. *Limited Warranty and Related Remedies/Disclaimers:*
 - 2.1 These terms and conditions do not apply to Software. The warranty, if any, for Software is covered in the applicable Software License Agreement.
 - 2.2 TI warrants that the TI EVM will conform to TI's published specifications for ninety (90) days after the date TI delivers such EVM to User. Notwithstanding the foregoing, TI shall not be liable for any defects that are caused by neglect, misuse or mistreatment by an entity other than TI, including improper installation or testing, or for any EVMs that have been altered or modified in any way by an entity other than TI. Moreover, TI shall not be liable for any defects that result from User's design, specifications or instructions for such EVMs. Testing and other quality control techniques are used to the extent TI deems necessary or as mandated by government requirements. TI does not test all parameters of each EVM.
 - 2.3 If any EVM fails to conform to the warranty set forth above, TI's sole liability shall be at its option to repair or replace such EVM, or credit User's account for such EVM. TI's liability under this warranty shall be limited to EVMs that are returned during the warranty period to the address designated by TI and that are determined by TI not to conform to such warranty. If TI elects to repair or replace such EVM, TI shall have a reasonable time to repair such EVM or provide replacements. Repaired EVMs shall be warranted for the remainder of the original warranty period. Replaced EVMs shall be warranted for a new full ninety (90) day warranty period.
3. *Regulatory Notices:*
 - 3.1 *United States*
 - 3.1.1 *Notice applicable to EVMs not FCC-Approved:*

This kit is designed to allow product developers to evaluate electronic components, circuitry, or software associated with the kit to determine whether to incorporate such items in a finished product and software developers to write software applications for use with the end product. This kit is not a finished product and when assembled may not be resold or otherwise marketed unless all required FCC equipment authorizations are first obtained. Operation is subject to the condition that this product not cause harmful interference to licensed radio stations and that this product accept harmful interference. Unless the assembled kit is designed to operate under part 15, part 18 or part 95 of this chapter, the operator of the kit must operate under the authority of an FCC license holder or must secure an experimental authorization under part 5 of this chapter.
 - 3.1.2 *For EVMs annotated as FCC – FEDERAL COMMUNICATIONS COMMISSION Part 15 Compliant:*

CAUTION

This device complies with part 15 of the FCC Rules. Operation is subject to the following two conditions: (1) This device may not cause harmful interference, and (2) this device must accept any interference received, including interference that may cause undesired operation.

Changes or modifications not expressly approved by the party responsible for compliance could void the user's authority to operate the equipment.

FCC Interference Statement for Class A EVM devices

NOTE: This equipment has been tested and found to comply with the limits for a Class A digital device, pursuant to part 15 of the FCC Rules. These limits are designed to provide reasonable protection against harmful interference when the equipment is operated in a commercial environment. This equipment generates, uses, and can radiate radio frequency energy and, if not installed and used in accordance with the instruction manual, may cause harmful interference to radio communications. Operation of this equipment in a residential area is likely to cause harmful interference in which case the user will be required to correct the interference at his own expense.

FCC Interference Statement for Class B EVM devices

NOTE: This equipment has been tested and found to comply with the limits for a Class B digital device, pursuant to part 15 of the FCC Rules. These limits are designed to provide reasonable protection against harmful interference in a residential installation. This equipment generates, uses and can radiate radio frequency energy and, if not installed and used in accordance with the instructions, may cause harmful interference to radio communications. However, there is no guarantee that interference will not occur in a particular installation. If this equipment does cause harmful interference to radio or television reception, which can be determined by turning the equipment off and on, the user is encouraged to try to correct the interference by one or more of the following measures:

- Reorient or relocate the receiving antenna.
- Increase the separation between the equipment and receiver.
- Connect the equipment into an outlet on a circuit different from that to which the receiver is connected.
- Consult the dealer or an experienced radio/TV technician for help.

3.2 Canada

3.2.1 For EVMs issued with an Industry Canada Certificate of Conformance to RSS-210

Concerning EVMs Including Radio Transmitters:

This device complies with Industry Canada license-exempt RSS standard(s). Operation is subject to the following two conditions: (1) this device may not cause interference, and (2) this device must accept any interference, including interference that may cause undesired operation of the device.

Concernant les EVMs avec appareils radio:

Le présent appareil est conforme aux CNR d'Industrie Canada applicables aux appareils radio exempts de licence. L'exploitation est autorisée aux deux conditions suivantes: (1) l'appareil ne doit pas produire de brouillage, et (2) l'utilisateur de l'appareil doit accepter tout brouillage radioélectrique subi, même si le brouillage est susceptible d'en compromettre le fonctionnement.

Concerning EVMs Including Detachable Antennas:

Under Industry Canada regulations, this radio transmitter may only operate using an antenna of a type and maximum (or lesser) gain approved for the transmitter by Industry Canada. To reduce potential radio interference to other users, the antenna type and its gain should be so chosen that the equivalent isotropically radiated power (e.i.r.p.) is not more than that necessary for successful communication. This radio transmitter has been approved by Industry Canada to operate with the antenna types listed in the user guide with the maximum permissible gain and required antenna impedance for each antenna type indicated. Antenna types not included in this list, having a gain greater than the maximum gain indicated for that type, are strictly prohibited for use with this device.

Concernant les EVMs avec antennes détachables

Conformément à la réglementation d'Industrie Canada, le présent émetteur radio peut fonctionner avec une antenne d'un type et d'un gain maximal (ou inférieur) approuvé pour l'émetteur par Industrie Canada. Dans le but de réduire les risques de brouillage radioélectrique à l'intention des autres utilisateurs, il faut choisir le type d'antenne et son gain de sorte que la puissance isotrope rayonnée équivalente (p.i.r.e.) ne dépasse pas l'intensité nécessaire à l'établissement d'une communication satisfaisante. Le présent émetteur radio a été approuvé par Industrie Canada pour fonctionner avec les types d'antenne énumérés dans le manuel d'usage et ayant un gain admissible maximal et l'impédance requise pour chaque type d'antenne. Les types d'antenne non inclus dans cette liste, ou dont le gain est supérieur au gain maximal indiqué, sont strictement interdits pour l'exploitation de l'émetteur.

3.3 Japan

3.3.1 *Notice for EVMs delivered in Japan:* Please see http://www.tij.co.jp/lstds/ti_ja/general/eStore/notice_01.page 日本国内に輸入される評価用キット、ボードについては、次のところをご覧ください。
http://www.tij.co.jp/lstds/ti_ja/general/eStore/notice_01.page

3.3.2 *Notice for Users of EVMs Considered "Radio Frequency Products" in Japan:* EVMs entering Japan may not be certified by TI as conforming to Technical Regulations of Radio Law of Japan.

If User uses EVMs in Japan, not certified to Technical Regulations of Radio Law of Japan, User is required by Radio Law of Japan to follow the instructions below with respect to EVMs:

1. Use EVMs in a shielded room or any other test facility as defined in the notification #173 issued by Ministry of Internal Affairs and Communications on March 28, 2006, based on Sub-section 1.1 of Article 6 of the Ministry's Rule for Enforcement of Radio Law of Japan,
2. Use EVMs only after User obtains the license of Test Radio Station as provided in Radio Law of Japan with respect to EVMs, or
3. Use of EVMs only after User obtains the Technical Regulations Conformity Certification as provided in Radio Law of Japan with respect to EVMs. Also, do not transfer EVMs, unless User gives the same notice above to the transferee. Please note that if User does not follow the instructions above, User will be subject to penalties of Radio Law of Japan.

【無線電波を送信する製品の開発キットをお使いになる際の注意事項】 開発キットの中には技術基準適合証明を受けていないものがあります。技術適合証明を受けていないもののご使用に際しては、電波法遵守のため、以下のいずれかの措置を取っていただく必要がありますのでご注意ください。

1. 電波法施行規則第6条第1項第1号に基づく平成18年3月28日総務省告示第173号で定められた電波暗室等の試験設備でご使用いただく。
2. 実験局の免許を取得後ご使用いただく。
3. 技術基準適合証明を取得後ご使用いただく。

なお、本製品は、上記の「ご使用にあたっての注意」を譲渡先、移転先に通知しない限り、譲渡、移転できないものとします。

上記を遵守頂けない場合は、電波法の罰則が適用される可能性があることをご留意ください。日本テキサス・インスツルメンツ株式会社

東京都新宿区西新宿 6 丁目 2 4 番 1 号

西新宿三井ビル

3.3.3 *Notice for EVMs for Power Line Communication:* Please see http://www.tij.co.jp/llds/ti_ja/general/eStore/notice_02.page
電力線搬送波通信についての開発キットをお使いになる際の注意事項については、次のところをご覧ください。http://www.tij.co.jp/llds/ti_ja/general/eStore/notice_02.page

4 *EVM Use Restrictions and Warnings:*

4.1 EVMS ARE NOT FOR USE IN FUNCTIONAL SAFETY AND/OR SAFETY CRITICAL EVALUATIONS, INCLUDING BUT NOT LIMITED TO EVALUATIONS OF LIFE SUPPORT APPLICATIONS.

4.2 User must read and apply the user guide and other available documentation provided by TI regarding the EVM prior to handling or using the EVM, including without limitation any warning or restriction notices. The notices contain important safety information related to, for example, temperatures and voltages.

4.3 *Safety-Related Warnings and Restrictions:*

4.3.1 User shall operate the EVM within TI's recommended specifications and environmental considerations stated in the user guide, other available documentation provided by TI, and any other applicable requirements and employ reasonable and customary safeguards. Exceeding the specified performance ratings and specifications (including but not limited to input and output voltage, current, power, and environmental ranges) for the EVM may cause personal injury or death, or property damage. If there are questions concerning performance ratings and specifications, User should contact a TI field representative prior to connecting interface electronics including input power and intended loads. Any loads applied outside of the specified output range may also result in unintended and/or inaccurate operation and/or possible permanent damage to the EVM and/or interface electronics. Please consult the EVM user guide prior to connecting any load to the EVM output. If there is uncertainty as to the load specification, please contact a TI field representative. During normal operation, even with the inputs and outputs kept within the specified allowable ranges, some circuit components may have elevated case temperatures. These components include but are not limited to linear regulators, switching transistors, pass transistors, current sense resistors, and heat sinks, which can be identified using the information in the associated documentation. When working with the EVM, please be aware that the EVM may become very warm.

4.3.2 EVMs are intended solely for use by technically qualified, professional electronics experts who are familiar with the dangers and application risks associated with handling electrical mechanical components, systems, and subsystems. User assumes all responsibility and liability for proper and safe handling and use of the EVM by User or its employees, affiliates, contractors or designees. User assumes all responsibility and liability to ensure that any interfaces (electronic and/or mechanical) between the EVM and any human body are designed with suitable isolation and means to safely limit accessible leakage currents to minimize the risk of electrical shock hazard. User assumes all responsibility and liability for any improper or unsafe handling or use of the EVM by User or its employees, affiliates, contractors or designees.

4.4 User assumes all responsibility and liability to determine whether the EVM is subject to any applicable international, federal, state, or local laws and regulations related to User's handling and use of the EVM and, if applicable, User assumes all responsibility and liability for compliance in all respects with such laws and regulations. User assumes all responsibility and liability for proper disposal and recycling of the EVM consistent with all applicable international, federal, state, and local requirements.

5. *Accuracy of Information:* To the extent TI provides information on the availability and function of EVMs, TI attempts to be as accurate as possible. However, TI does not warrant the accuracy of EVM descriptions, EVM availability or other information on its websites as accurate, complete, reliable, current, or error-free.

6. *Disclaimers:*
- 6.1 EXCEPT AS SET FORTH ABOVE, EVMS AND ANY WRITTEN DESIGN MATERIALS PROVIDED WITH THE EVM (AND THE DESIGN OF THE EVM ITSELF) ARE PROVIDED "AS IS" AND "WITH ALL FAULTS." TI DISCLAIMS ALL OTHER WARRANTIES, EXPRESS OR IMPLIED, REGARDING SUCH ITEMS, INCLUDING BUT NOT LIMITED TO ANY IMPLIED WARRANTIES OF MERCHANTABILITY OR FITNESS FOR A PARTICULAR PURPOSE OR NON-INFRINGEMENT OF ANY THIRD PARTY PATENTS, COPYRIGHTS, TRADE SECRETS OR OTHER INTELLECTUAL PROPERTY RIGHTS.
- 6.2 EXCEPT FOR THE LIMITED RIGHT TO USE THE EVM SET FORTH HEREIN, NOTHING IN THESE TERMS AND CONDITIONS SHALL BE CONSTRUED AS GRANTING OR CONFERRING ANY RIGHTS BY LICENSE, PATENT, OR ANY OTHER INDUSTRIAL OR INTELLECTUAL PROPERTY RIGHT OF TI, ITS SUPPLIERS/LICENSORS OR ANY OTHER THIRD PARTY, TO USE THE EVM IN ANY FINISHED END-USER OR READY-TO-USE FINAL PRODUCT, OR FOR ANY INVENTION, DISCOVERY OR IMPROVEMENT MADE, CONCEIVED OR ACQUIRED PRIOR TO OR AFTER DELIVERY OF THE EVM.
7. *USER'S INDEMNITY OBLIGATIONS AND REPRESENTATIONS.* USER WILL DEFEND, INDEMNIFY AND HOLD TI, ITS LICENSORS AND THEIR REPRESENTATIVES HARMLESS FROM AND AGAINST ANY AND ALL CLAIMS, DAMAGES, LOSSES, EXPENSES, COSTS AND LIABILITIES (COLLECTIVELY, "CLAIMS") ARISING OUT OF OR IN CONNECTION WITH ANY HANDLING OR USE OF THE EVM THAT IS NOT IN ACCORDANCE WITH THESE TERMS AND CONDITIONS. THIS OBLIGATION SHALL APPLY WHETHER CLAIMS ARISE UNDER STATUTE, REGULATION, OR THE LAW OF TORT, CONTRACT OR ANY OTHER LEGAL THEORY, AND EVEN IF THE EVM FAILS TO PERFORM AS DESCRIBED OR EXPECTED.
8. *Limitations on Damages and Liability:*
- 8.1 *General Limitations.* IN NO EVENT SHALL TI BE LIABLE FOR ANY SPECIAL, COLLATERAL, INDIRECT, PUNITIVE, INCIDENTAL, CONSEQUENTIAL, OR EXEMPLARY DAMAGES IN CONNECTION WITH OR ARISING OUT OF THESE TERMS AND CONDITIONS OR THE USE OF THE EVMS PROVIDED HEREUNDER, REGARDLESS OF WHETHER TI HAS BEEN ADVISED OF THE POSSIBILITY OF SUCH DAMAGES. EXCLUDED DAMAGES INCLUDE, BUT ARE NOT LIMITED TO, COST OF REMOVAL OR REINSTALLATION, ANCILLARY COSTS TO THE PROCUREMENT OF SUBSTITUTE GOODS OR SERVICES, RETESTING, OUTSIDE COMPUTER TIME, LABOR COSTS, LOSS OF GOODWILL, LOSS OF PROFITS, LOSS OF SAVINGS, LOSS OF USE, LOSS OF DATA, OR BUSINESS INTERRUPTION. NO CLAIM, SUIT OR ACTION SHALL BE BROUGHT AGAINST TI MORE THAN ONE YEAR AFTER THE RELATED CAUSE OF ACTION HAS OCCURRED.
- 8.2 *Specific Limitations.* IN NO EVENT SHALL TI'S AGGREGATE LIABILITY FROM ANY WARRANTY OR OTHER OBLIGATION ARISING OUT OF OR IN CONNECTION WITH THESE TERMS AND CONDITIONS, OR ANY USE OF ANY TI EVM PROVIDED HEREUNDER, EXCEED THE TOTAL AMOUNT PAID TO TI FOR THE PARTICULAR UNITS SOLD UNDER THESE TERMS AND CONDITIONS WITH RESPECT TO WHICH LOSSES OR DAMAGES ARE CLAIMED. THE EXISTENCE OF MORE THAN ONE CLAIM AGAINST THE PARTICULAR UNITS SOLD TO USER UNDER THESE TERMS AND CONDITIONS SHALL NOT ENLARGE OR EXTEND THIS LIMIT.
9. *Return Policy.* Except as otherwise provided, TI does not offer any refunds, returns, or exchanges. Furthermore, no return of EVM(s) will be accepted if the package has been opened and no return of the EVM(s) will be accepted if they are damaged or otherwise not in a resalable condition. If User feels it has been incorrectly charged for the EVM(s) it ordered or that delivery violates the applicable order, User should contact TI. All refunds will be made in full within thirty (30) working days from the return of the components(s), excluding any postage or packaging costs.
10. *Governing Law:* These terms and conditions shall be governed by and interpreted in accordance with the laws of the State of Texas, without reference to conflict-of-laws principles. User agrees that non-exclusive jurisdiction for any dispute arising out of or relating to these terms and conditions lies within courts located in the State of Texas and consents to venue in Dallas County, Texas. Notwithstanding the foregoing, any judgment may be enforced in any United States or foreign court, and TI may seek injunctive relief in any United States or foreign court.

Mailing Address: Texas Instruments, Post Office Box 655303, Dallas, Texas 75265
Copyright © 2015, Texas Instruments Incorporated

IMPORTANT NOTICE

Texas Instruments Incorporated and its subsidiaries (TI) reserve the right to make corrections, enhancements, improvements and other changes to its semiconductor products and services per JESD46, latest issue, and to discontinue any product or service per JESD48, latest issue. Buyers should obtain the latest relevant information before placing orders and should verify that such information is current and complete. All semiconductor products (also referred to herein as "components") are sold subject to TI's terms and conditions of sale supplied at the time of order acknowledgment.

TI warrants performance of its components to the specifications applicable at the time of sale, in accordance with the warranty in TI's terms and conditions of sale of semiconductor products. Testing and other quality control techniques are used to the extent TI deems necessary to support this warranty. Except where mandated by applicable law, testing of all parameters of each component is not necessarily performed.

TI assumes no liability for applications assistance or the design of Buyers' products. Buyers are responsible for their products and applications using TI components. To minimize the risks associated with Buyers' products and applications, Buyers should provide adequate design and operating safeguards.

TI does not warrant or represent that any license, either express or implied, is granted under any patent right, copyright, mask work right, or other intellectual property right relating to any combination, machine, or process in which TI components or services are used. Information published by TI regarding third-party products or services does not constitute a license to use such products or services or a warranty or endorsement thereof. Use of such information may require a license from a third party under the patents or other intellectual property of the third party, or a license from TI under the patents or other intellectual property of TI.

Reproduction of significant portions of TI information in TI data books or data sheets is permissible only if reproduction is without alteration and is accompanied by all associated warranties, conditions, limitations, and notices. TI is not responsible or liable for such altered documentation. Information of third parties may be subject to additional restrictions.

Resale of TI components or services with statements different from or beyond the parameters stated by TI for that component or service voids all express and any implied warranties for the associated TI component or service and is an unfair and deceptive business practice. TI is not responsible or liable for any such statements.

Buyer acknowledges and agrees that it is solely responsible for compliance with all legal, regulatory and safety-related requirements concerning its products, and any use of TI components in its applications, notwithstanding any applications-related information or support that may be provided by TI. Buyer represents and agrees that it has all the necessary expertise to create and implement safeguards which anticipate dangerous consequences of failures, monitor failures and their consequences, lessen the likelihood of failures that might cause harm and take appropriate remedial actions. Buyer will fully indemnify TI and its representatives against any damages arising out of the use of any TI components in safety-critical applications.

In some cases, TI components may be promoted specifically to facilitate safety-related applications. With such components, TI's goal is to help enable customers to design and create their own end-product solutions that meet applicable functional safety standards and requirements. Nonetheless, such components are subject to these terms.

No TI components are authorized for use in FDA Class III (or similar life-critical medical equipment) unless authorized officers of the parties have executed a special agreement specifically governing such use.

Only those TI components which TI has specifically designated as military grade or "enhanced plastic" are designed and intended for use in military/aerospace applications or environments. Buyer acknowledges and agrees that any military or aerospace use of TI components which have **not** been so designated is solely at the Buyer's risk, and that Buyer is solely responsible for compliance with all legal and regulatory requirements in connection with such use.

TI has specifically designated certain components as meeting ISO/TS16949 requirements, mainly for automotive use. In any case of use of non-designated products, TI will not be responsible for any failure to meet ISO/TS16949.

Products

Audio	www.ti.com/audio
Amplifiers	amplifier.ti.com
Data Converters	dataconverter.ti.com
DLP® Products	www.dlp.com
DSP	dsp.ti.com
Clocks and Timers	www.ti.com/clocks
Interface	interface.ti.com
Logic	logic.ti.com
Power Mgmt	power.ti.com
Microcontrollers	microcontroller.ti.com
RFID	www.ti-rfid.com
OMAP Applications Processors	www.ti.com/omap
Wireless Connectivity	www.ti.com/wirelessconnectivity

Applications

Automotive and Transportation	www.ti.com/automotive
Communications and Telecom	www.ti.com/communications
Computers and Peripherals	www.ti.com/computers
Consumer Electronics	www.ti.com/consumer-apps
Energy and Lighting	www.ti.com/energy
Industrial	www.ti.com/industrial
Medical	www.ti.com/medical
Security	www.ti.com/security
Space, Avionics and Defense	www.ti.com/space-avionics-defense
Video and Imaging	www.ti.com/video

TI E2E Community

e2e.ti.com