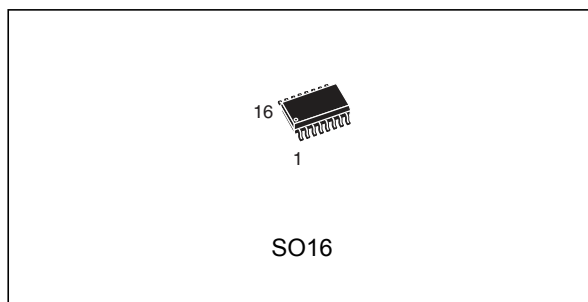

3 V NVRAM supervisor for LPSRAM

Datasheet - production data

**Description**

The M40SZ100W NVRAM controller is a self-contained device which converts a standard low-power SRAM into a non-volatile memory. A precision voltage reference and comparator monitors the V_{CC} input for an out-of-tolerance condition.

When an invalid V_{CC} condition occurs, the conditioned chip enable output (\overline{E}_{CON}) is forced inactive to write protect the stored data in the SRAM. During a power failure, the SRAM is switched from the V_{CC} pin to the external battery to provide the energy required for data retention. On a subsequent power-up, the SRAM remains write-protected until a valid power condition returns.

Features

- Convert low power SRAMs into NVRAMs
- 3 V operating voltage
- Precision power monitoring and power switching circuitry
- Automatic write-protection when V_{CC} is out-of-tolerance
- Choice of supply voltage and power-fail deselect voltage:
 - $V_{CC} = 2.7$ to 3.6 V; 2.55 V $\leq V_{PFD} \leq 2.70$ V
- Reset output (\overline{RST}) for power on reset
- 1.25 V reference (for PFI/ \overline{PFO})
- Less than 15 ns chip enable access propagation delay
- Battery low pin (\overline{BL})
- RoHS compliant
 - Lead-free second level interconnect

Contents

- 1 Device overview 5**
- 2 Operation 8**
 - 2.1 Data retention lifetime calculation 8
 - 2.2 Power-on reset output 11
 - 2.3 Reset input (RSTIN) 11
 - 2.4 Battery low pin 11
 - 2.5 Power-fail input/output 12
 - 2.6 V_{CC} noise and negative going transients 12
- 3 Maximum ratings 14**
- 4 DC and AC parameters 15**
- 5 Package mechanical data 17**
- 6 Part numbering 18**
- 7 Revision history 19**

List of tables

Table 1.	Signal names	5
Table 2.	Power-down/up AC characteristics	10
Table 3.	Reset AC characteristics	11
Table 4.	Absolute maximum ratings	14
Table 5.	DC and AC measurement conditions	15
Table 6.	Capacitance	15
Table 7.	DC characteristics	16
Table 8.	SO16 – 16-lead plastic small outline package mechanical data	17
Table 9.	Ordering information scheme	18
Table 10.	Document revision history	19

List of figures

Figure 1.	Logic diagram	5
Figure 2.	Pin connections	6
Figure 3.	Block diagram	6
Figure 4.	Hardware hookup	7
Figure 5.	Power-down timing	9
Figure 6.	Power-up timing	10
Figure 7.	$\overline{\text{RSTIN}}$ timing waveform	11
Figure 8.	Supply voltage protection	13
Figure 9.	AC testing load circuit	15
Figure 10.	AC testing input/output waveforms	15
Figure 11.	SO16 – 16-lead plastic small package outline	17

1 Device overview

Figure 1. Logic diagram

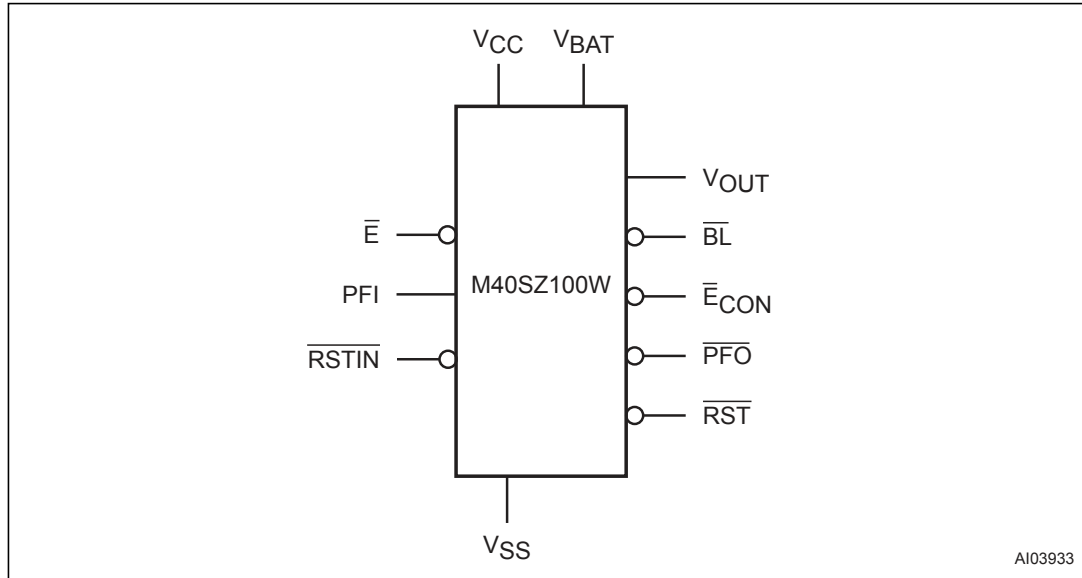
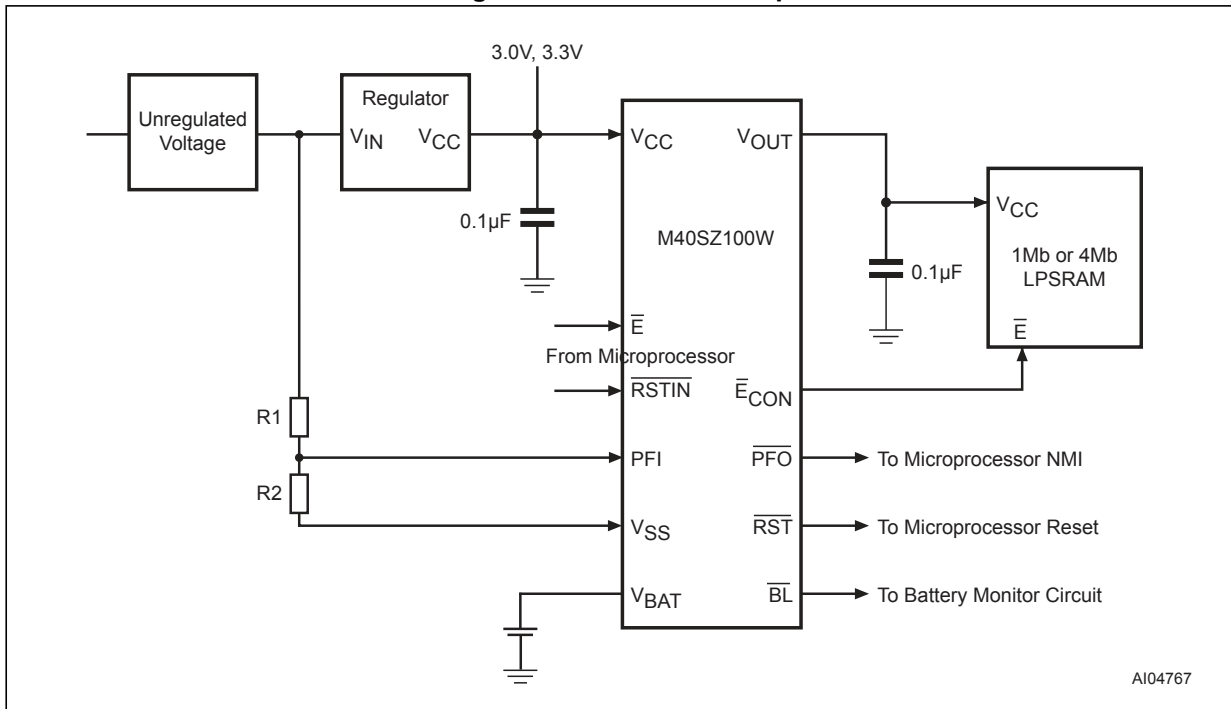

Table 1. Signal names

\bar{E}	Chip enable input
\bar{E}_{CON}	Conditioned chip enable output
\bar{RST}	Reset output (open drain)
\bar{RSTIN}	Reset input
\bar{BL}	Battery low output (open drain)
V_{OUT}	Supply voltage output
V_{CC}	Supply voltage
V_{BAT}	Backup supply voltage
PFI	Power fail input
\bar{PFO}	Power fail output
V_{SS}	Ground
NC	Not connected internally

Figure 4. Hardware hookup



2 Operation

The M40SZ100W, as shown in [Figure 4 on page 7](#), can control one (two, if placed in parallel) standard low-power SRAM. This SRAM must be configured to have the chip enable input disable all other input signals. Most slow, low-power SRAMs are configured like this, however many fast SRAMs are not. During normal operating conditions, the conditioned chip enable (\overline{E}_{CON}) output pin follows the chip enable (\overline{E}) input pin with timing shown in [Table 2 on page 10](#). An internal switch connects V_{CC} to V_{OUT} . This switch has a voltage drop of less than 0.3 V (I_{OUT1}).

When V_{CC} degrades during a power failure, \overline{E}_{CON} is forced inactive independent of \overline{E} . In this situation, the SRAM is unconditionally write protected as V_{CC} falls below an out-of-tolerance threshold (V_{PFD}). For the M40SZ100W the power fail detection value associated with V_{PFD} is shown in [Table 7 on page 16](#).

If chip enable access is in progress during a power fail detection, that memory cycle continues to completion before the memory is write protected. If the memory cycle is not terminated within time t_{WPT} , \overline{E}_{CON} is unconditionally driven high, write protecting the SRAM. A power failure during a WRITE cycle may corrupt data at the currently addressed location, but does not jeopardize the rest of the SRAM's contents. At voltages below V_{PFD} (min), the user can be assured the memory will be write protected within the Write Protect Time (t_{WPT}) provided the V_{CC} fall time does not exceed t_F (see [Table 2 on page 10](#)).

As V_{CC} continues to degrade, the internal switch disconnects V_{CC} and connects the internal battery to V_{OUT} . This occurs at the switchover voltage (V_{SO}). Below the V_{SO} , the battery provides a voltage V_{OHB} to the SRAM and can supply current I_{OUT2} (see [Table 7 on page 16](#)).

When V_{CC} rises above V_{SO} , V_{OUT} is switched back to the supply voltage. Output \overline{E}_{CON} is held inactive for t_{CEB} (120 ms maximum) after the power supply has reached V_{PFD} , independent of the \overline{E} input, to allow for processor stabilization (see [Figure 6 on page 10](#)).

2.1 Data retention lifetime calculation

Most low power SRAMs on the market today can be used with the M40SZ100W NVRAM controller. There are, however some criteria which should be used in making the final choice of which SRAM to use. The SRAM must be designed in a way where the chip enable input disables all other inputs to the SRAM. This allows inputs to the M40SZ100W and SRAMs to be "Don't care" once V_{CC} falls below V_{PFD} (min) (see [Figure 5 on page 9](#)). The SRAM should also guarantee data retention down to $V_{CC} = 2.0$ V. The chip enable access time must be sufficient to meet the system needs with the chip enable propagation delays included.

If data retention lifetime is a critical parameter for the system, it is important to review the data retention current specifications for the particular SRAMs being evaluated. Most SRAMs specify a data retention current at 3.0 V. Manufacturers generally specify a typical condition for room temperature along with a worst case condition (generally at elevated temperatures). The system level requirements will determine the choice of which value to use. The data retention current value of the SRAMs can then be added to the I_{CCDR} value of the M40SZ100W to determine the total current requirements for data retention.

Caution: Take care to avoid inadvertent discharge through V_{OUT} and \overline{E}_{CON} after battery has been attached.

For a further more detailed review of lifetime calculations, please see application note AN1012.

Figure 5. Power-down timing

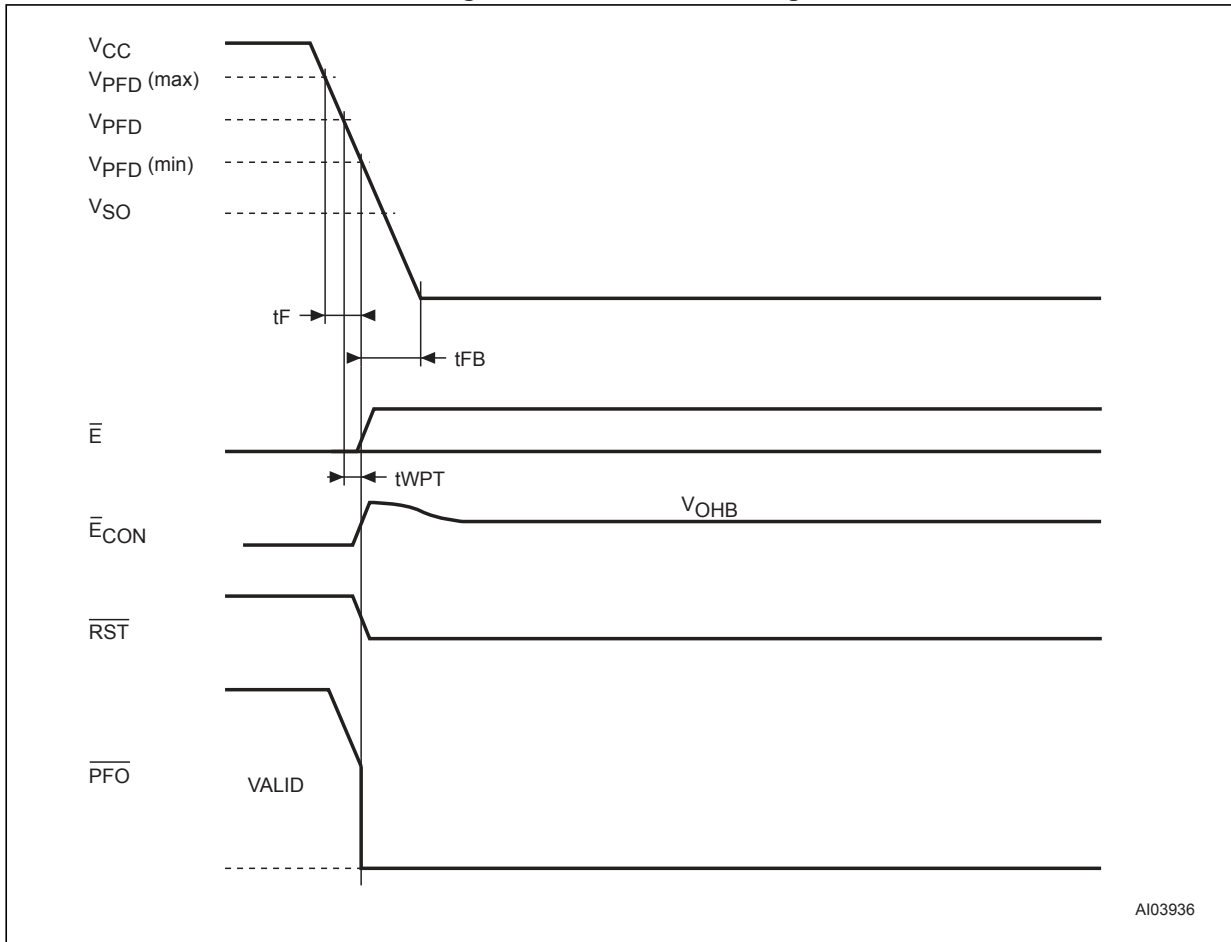

Figure 6. Power-up timing

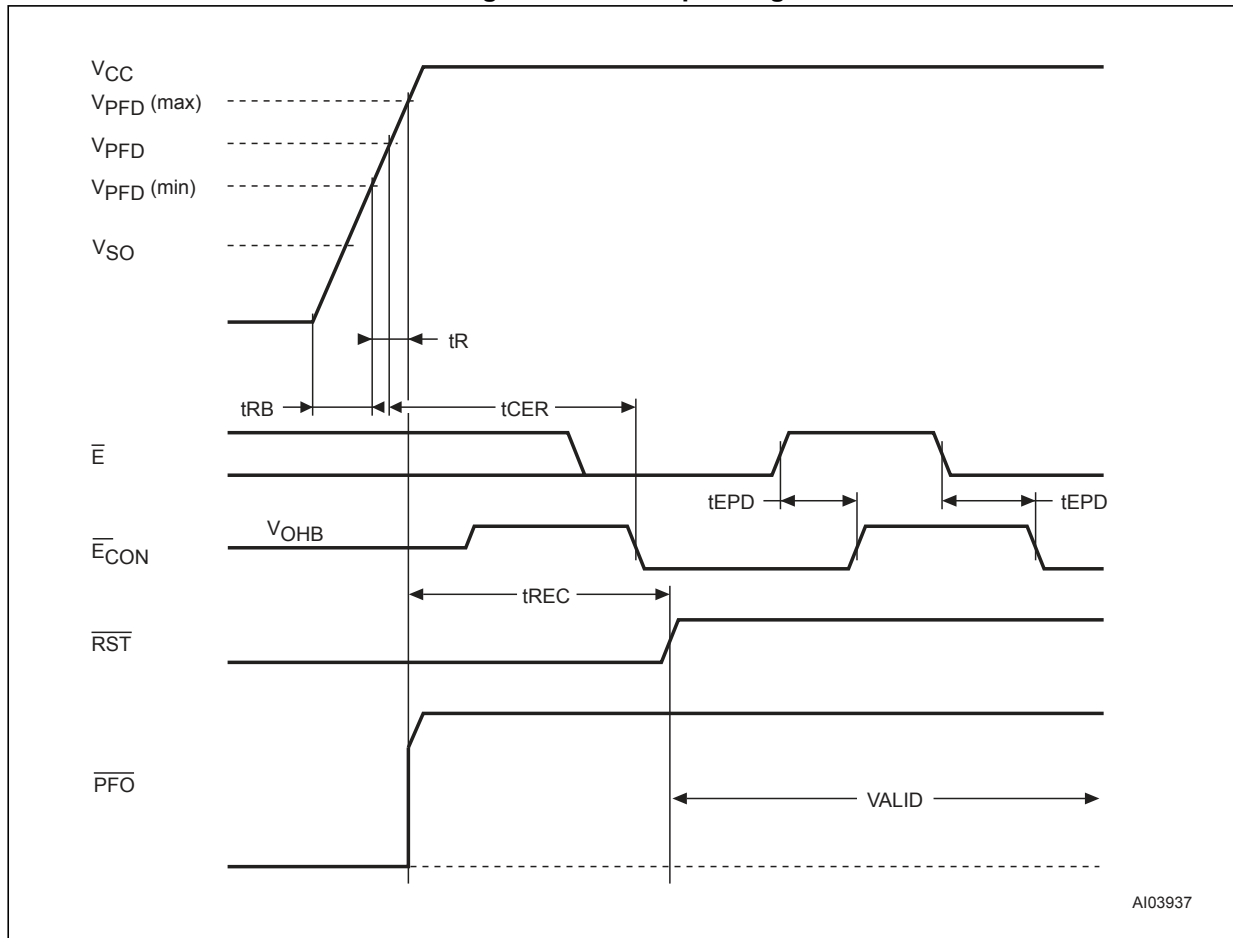

Table 2. Power-down/up AC characteristics

Symbol	Parameter ⁽¹⁾	Min	Max	Unit
$t_F^{(2)}$	$V_{PFD}(\max)$ to $V_{PFD}(\min)$ V_{CC} fall time	300		μs
$t_{FB}^{(3)}$	$V_{PFD}(\min)$ to V_{SS} V_{CC} fall time	10		μs
t_{PFD}	PFI to \bar{PFO} propagation delay	15	25	μs
t_R	$V_{PFD}(\min)$ to $V_{PFD}(\max)$ V_{CC} rise time	10		μs
t_{EPD}	Chip enable propagation delay (low or high)		15	ns
t_{RB}	V_{SS} to $V_{PFD}(\min)$ V_{CC} rise time	1		μs
t_{CER}	Chip enable recovery	40	120	ms
t_{REC}	$V_{PFD}(\max)$ to \bar{RST} high	40	200	ms
t_{WPT}	Write protect time	40	200	μs

- Valid for ambient operating temperature: $T_A = -40$ to 85 °C; $V_{CC} = 2.7$ to 3.6 V (except where noted).
- $V_{PFD}(\max)$ to $V_{PFD}(\min)$ fall time of less than t_F may result in deselection/write protection not occurring until 200 μs after V_{CC} passes $V_{PFD}(\min)$.
- $V_{PFD}(\min)$ to V_{SS} fall time of less than t_{FB} may cause corruption of RAM data.

2.2 Power-on reset output

All microprocessors have a reset input which forces them to a known state when starting. The M40SZ100W has a reset output ($\overline{\text{RST}}$) pin which is guaranteed to be low by V_{PFD} (see [Table 7 on page 16](#)). This signal is an open drain configuration. An appropriate pull-up resistor to V_{CC} should be chosen to control the rise time. This signal will be valid for all voltage conditions, even when V_{CC} equals V_{SS} (with valid battery voltage).

Once V_{CC} exceeds the power failure detect voltage V_{PFD} , an internal timer keeps $\overline{\text{RST}}$ low for t_{REC} to allow the power supply to stabilize.

2.3 Reset input ($\overline{\text{RSTIN}}$)

The M40SZ100W provides one independent input which can generate an output reset. The duration and function of this reset is identical to a reset generated by a power cycle. [Table 3](#) and [Figure 7](#) illustrate the AC reset characteristics of this function. Pulses shorter than t_{RLRH} will not generate a reset condition. $\overline{\text{RSTIN}}$ is internally pulled up to V_{CC} through a 100 k Ω resistor.

Figure 7. $\overline{\text{RSTIN}}$ timing waveform

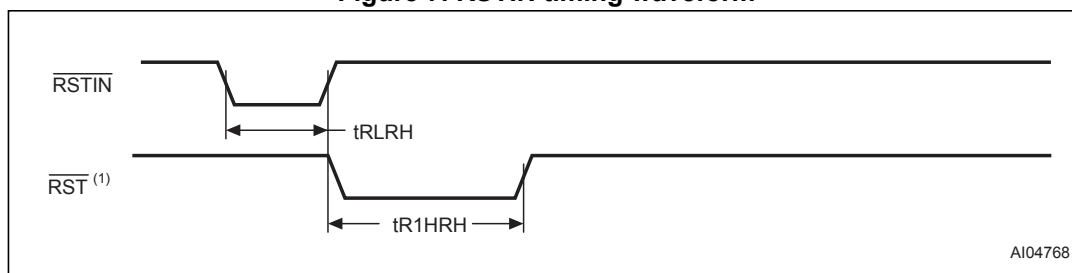

1. With pull-up resistor

Table 3. Reset AC characteristics

Symbol	Parameter ⁽¹⁾	Min	Max	Unit
$t_{\text{RLRH}}^{(2)}$	RSTIN low to RSTIN high	200		ns
$t_{\text{R1HRH}}^{(3)}$	RSTIN high to RST high	40	200	ms

1. Valid for ambient operating temperature: $T_A = -40$ to 85 °C; $V_{\text{CC}} = 2.7$ to 3.6 V (except where noted).

2. Pulse width less than 50 ns will result in no RESET (for noise immunity).

3. $C_L = 50$ pF (see [Figure 9 on page 15](#)).

2.4 Battery low pin

The M40SZ100W automatically performs battery voltage monitoring upon power-up, and at factory-programmed time intervals of at least 24 hours. The Battery Low ($\overline{\text{BL}}$) pin will be asserted if the battery voltage is found to be less than approximately 2.5 V. The $\overline{\text{BL}}$ pin will remain asserted until completion of battery replacement and subsequent battery low monitoring tests, either during the next power-up sequence or the next scheduled 24-hour interval.

If a battery low is generated during a power-up sequence, this indicates that the battery is below 2.5 V and may not be able to maintain data integrity in the SRAM. Data should be considered suspect, and verified as correct. A fresh battery should be installed.

If a battery low indication is generated during the 24-hour interval check, this indicates that the battery is near end of life. However, data is not compromised due to the fact that a nominal V_{CC} is supplied. In order to insure data integrity during subsequent periods of battery back-up mode, the battery should be replaced.

The M40SZ100W only monitors the battery when a nominal V_{CC} is applied to the device. Thus applications which require extensive durations in the battery backup mode should be powered-up periodically (at least once every few months) in order for this technique to be beneficial. Additionally, if a battery low is indicated, data integrity should be verified upon power-up via a checksum or other technique. The \overline{BL} pin is an open drain output and an appropriate pull-up resistor to V_{CC} should be chosen to control the rise time.

2.5 Power-fail input/output

The power-fail input (PFI) is compared to an internal reference voltage (independent from the V_{PFD} comparator). If PFI is less than the power-fail threshold (V_{PFI}), the power-fail output (PFO) will go low. This function is intended for use as an undervoltage detector to signal a failing power supply. Typically PFI is connected through an external voltage divider (see [Figure 4 on page 7](#)) to either the unregulated DC input (if it is available) or the regulated output of the V_{CC} regulator. The voltage divider can be set up such that the voltage at PFI falls below V_{PFI} several milliseconds before the regulated V_{CC} input to the M40SZ100W or the microprocessor drops below the minimum operating voltage.

During battery backup, the power-fail comparator turns off and \overline{PFO} goes (or remains) low. This occurs after V_{CC} drops below $V_{PFD}(\min)$. When power returns, \overline{PFO} is forced high, irrespective of V_{PFI} for the write protect time (t_{REC}), which is the time from $V_{PFD}(\max)$ until the inputs are recognized. At the end of this time, the power-fail comparator is enabled and \overline{PFO} follows PFI. If the comparator is unused, PFI should be connected to V_{SS} and \overline{PFO} left unconnected.

2.6 V_{CC} noise and negative going transients

I_{CC} transients, including those produced by output switching, can produce voltage fluctuations, resulting in spikes on the V_{CC} bus. These transients can be reduced if capacitors are used to store energy which stabilizes the V_{CC} bus. The energy stored in the bypass capacitors will be released as low going spikes are generated or energy will be absorbed when overshoots occur. A ceramic bypass capacitor value of 0.1 μF (as shown in [Figure 8 on page 13](#)) is recommended in order to provide the needed filtering.

In addition to transients that are caused by normal SRAM operation, power cycling can generate negative voltage spikes on V_{CC} that drive it to values below V_{SS} by as much as one volt. These negative spikes can cause data corruption in the SRAM while in battery backup mode. To protect from these voltage spikes, STMicroelectronics recommends connecting a Schottky diode from V_{CC} to V_{SS} (cathode connected to V_{CC} , anode to V_{SS}). Schottky diode 1N5817 is recommended for through hole and MBR5120T3 is recommended for surface mount.

Figure 8. Supply voltage protection

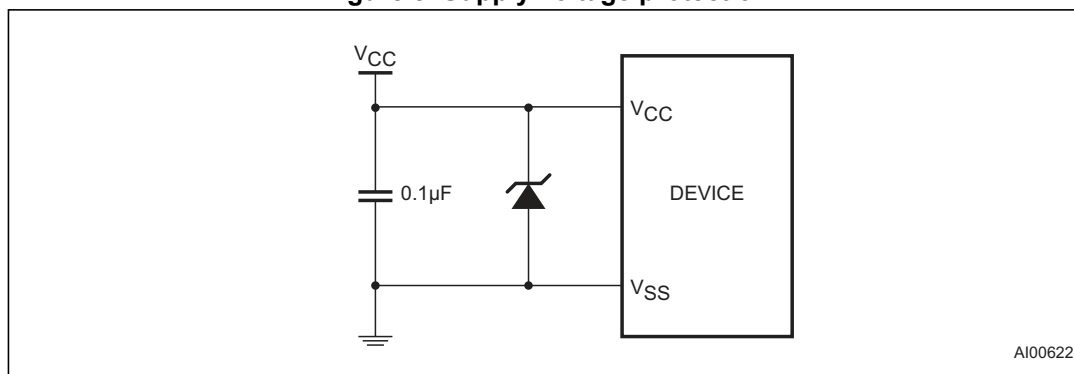

3 Maximum ratings

Stressing the device above the rating listed in the absolute maximum ratings table may cause permanent damage to the device. These are stress ratings only and operation of the device at these or any other conditions above those indicated in the operating sections of this specification is not implied. Exposure to absolute maximum rating conditions for extended periods may affect device reliability.

Table 4. Absolute maximum ratings

Symbol	Parameter	Value	Unit
T_{STG}	Storage temperature (V_{CC} off)	-55 to 125	°C
$T_{SLD}^{(1)}$	Lead solder temperature for 10 seconds	260	°C
V_{IO}	Input or output voltages	-0.3 to $V_{CC} + 0.3$	V
V_{CC}	Supply voltage	-0.3 to 4.6	V
I_O	Output current	20	mA
P_D	Power dissipation	1	W

1. For SO package, Lead-free (Pb-free) lead finish: reflow at peak temperature of 260 °C (the time above 255 °C must not exceed 30 seconds).

Caution: Negative undershoots below -0.3 V are not allowed on any pin while in the battery backup mode.

4 DC and AC parameters

This section summarizes the operating and measurement conditions, as well as the DC and AC characteristics of the device. The parameters in the following DC and AC characteristic tables are derived from tests performed under the measurement conditions listed in [Table 5: DC and AC measurement conditions](#). Designers should check that the operating conditions in their projects match the measurement conditions when using the quoted parameters.

Table 5. DC and AC measurement conditions

Parameter	Value
V _{CC} supply voltage	2.7 to 3.6 V
Ambient operating temperature	-40 to 85 °C
Load capacitance (C _L)	50 pF
Input rise and fall times	≤ 5 ns
Input pulse voltages	0.2 to 0.8V _{CC}
Input and output timing ref. voltages	0.3 to 0.7V _{CC}

Figure 9. AC testing load circuit

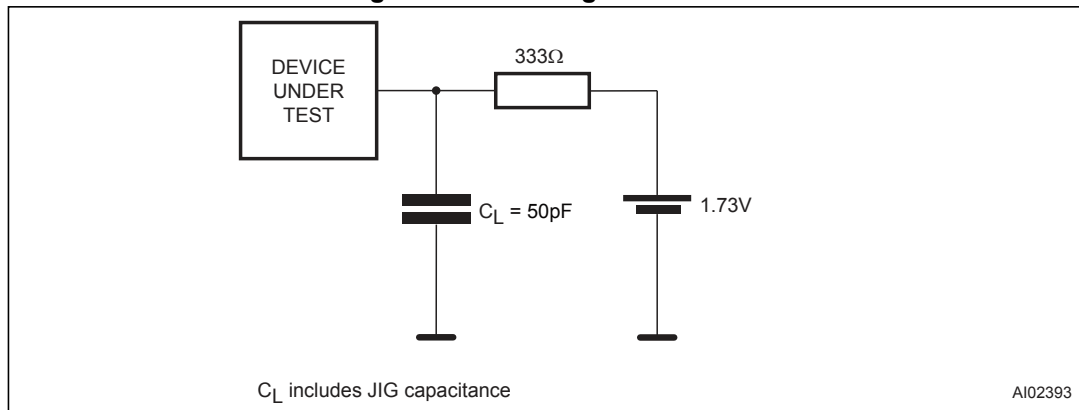

Figure 10. AC testing input/output waveforms

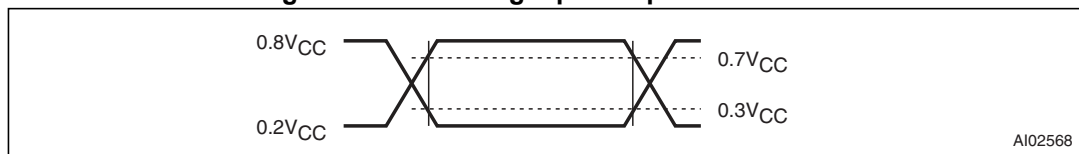

Table 6. Capacitance

Symbol	Parameter ⁽¹⁾⁽²⁾	Min	Max	Unit
C _{IN}	Input capacitance	-	7	pF
C _{OUT} ⁽³⁾	Output capacitance	-	10	pF

1. Sampled only, not 100% tested.
2. At 25 °C, f = 1 MHz.
3. Outputs deselected.

Table 7. DC characteristics

Sym	Parameter	Test condition ⁽¹⁾	Min	Typ	Max	Unit
I _{CC}	Supply current	Outputs open			0.5	mA
I _{CCDR}	Data retention mode current ⁽²⁾			50	200	nA
I _{LI} ⁽³⁾	Input leakage current	$0\text{ V} \leq V_{IN} \leq V_{CC}$			±1	µA
	Input leakage current (PFI)		-25	2	25	nA
I _{LO} ⁽⁴⁾	Output leakage current	$0\text{ V} \leq V_{OUT} \leq V_{CC}$			±1	µA
I _{OUT1} ⁽⁵⁾	V _{OUT} current (active)	$V_{OUT} > V_{CC} - 0.3$			100	mA
I _{OUT2}	V _{OUT} current (battery backup)	$V_{OUT} > V_{BAT} - 0.3$			100	µA
V _{BAT}	Battery voltage		2.5	3.0	3.5 ⁽⁶⁾	V
V _{IH}	Input high voltage		$0.7V_{CC}$		$V_{CC} + 0.3$	V
V _{IL}	Input low voltage		-0.3		$0.3V_{CC}$	V
V _{OH}	Output high voltage ⁽⁶⁾	I _{OH} = -1.0 mA	2.4			V
V _{OHB}	V _{OH} battery backup ⁽⁷⁾	I _{OUT2} = -1.0 µA	2.5	2.9	3.5	V
V _{OL}	Output low voltage	I _{OL} = 3.0 mA			0.4	V
	Output low voltage (open drain) ⁽⁸⁾	I _{OL} = 10 mA			0.4	V
V _{PFD}	Power-fail deselect voltage		2.55	2.60	2.70	V
V _{PFI}	PFI input threshold	V _{CC} = 3 V	1.225	1.250	1.275	V
	PFI hysteresis	PFI rising		20	70	mV
V _{SO}	Battery backup switchover voltage			2.5		V

- Valid for ambient operating temperature: T_A = -40 to 85 °C; V_{CC} = 2.7 to 3.6 V (except where noted).
- Measured with V_{OUT} and \overline{E}_{CON} open.
- \overline{RSTIN} internally pulled-up to V_{CC} through 100 kΩ resistor.
- Outputs deselected.
- External SRAM must match SUPERVISOR chip V_{CC} specification.
- For \overline{PFO} pin (CMOS).
- Chip enable output (\overline{E}_{CON}) can only sustain CMOS leakage currents in the battery backup mode. Higher leakage currents will reduce battery life.
- For \overline{RST} & \overline{BL} pins (open drain).

5 Package mechanical data

In order to meet environmental requirements, ST offers these devices in different grades of ECOPACK[®] packages, depending on their level of environmental compliance. ECOPACK[®] specifications, grade definitions and product status are available at: www.st.com. ECOPACK[®] is an ST trademark.

Figure 11. SO16 – 16-lead plastic small package outline

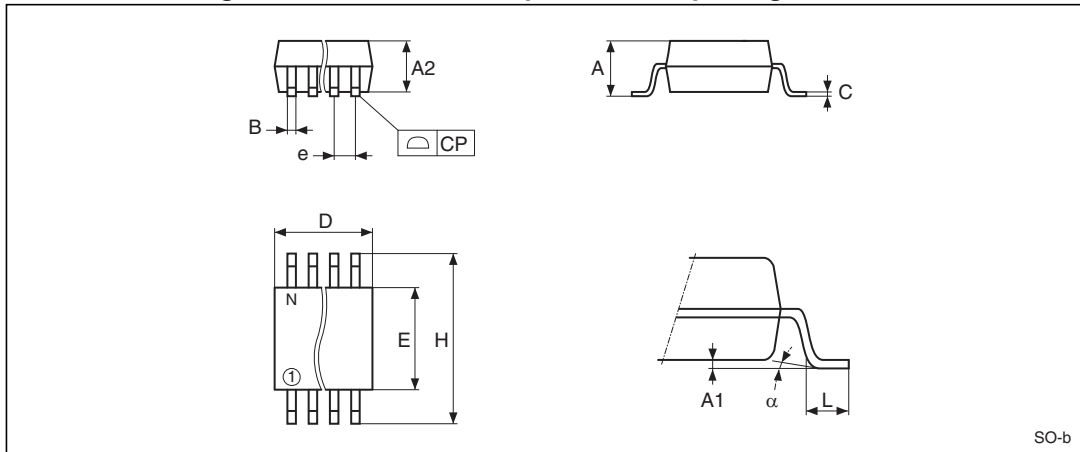

Note: Drawing is not to scale.

Table 8. SO16 – 16-lead plastic small outline package mechanical data

Symbol	mm			inches		
	Typ.	Min.	Max.	Typ.	Min.	Max.
A			1.75			0.069
A1		0.10	0.25		0.004	0.010
A2			1.60			0.063
B		0.35	0.46		0.014	0.018
C		0.19	0.25		0.007	0.010
D		9.80	10.00		0.386	0.394
E		3.80	4.00		0.150	0.158
e	1.27	–	–	0.050	–	–
H		5.80	6.20		0.228	0.244
L		0.40	1.27		0.016	0.050
a		0°	8°		0°	8°
N	16			16		
CP			0.10			0.004

6 Part numbering

Table 9. Ordering information scheme

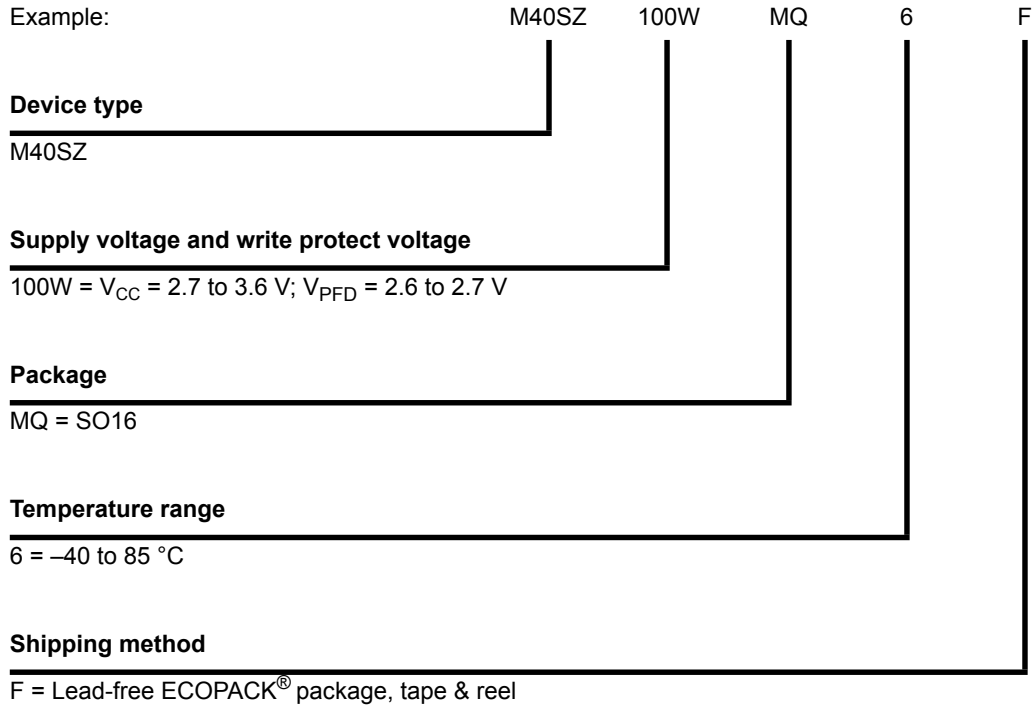

For a list of available options (e.g., speed, package) or for further information on any aspect of this device, please contact the ST sales office nearest to you.

7 Revision history

Table 10. Document revision history

Date	Revision	Changes
Dec-2001	1.0	First issue
13-May-2002	1.1	Modify reflow time and temperature footnote (Table 4)
01-Aug-2002	1.2	Add marketing status (cover page; Table 9)
15-Sep-2003	1.3	Remove reference to M68xxx (obsolete) part (Figure 4); update disclaimer
20-Nov-2007	2	Reformatted document; added lead-free second level interconnect information to cover page and Section 5: Package mechanical data ; updated Table 4 and 9 .
25-Oct-2010	3	Updated cover page, Section 3 , Table 9 , ECOPACK [®] text in Section 5 ; reformatted document; minor textual changes.
16-Dec-2013	4	Removed SNAPHAT and SOH28 package option as well as 5 V part (M40SZ100Y) from datasheet Removed shipping option in tubes from Table 9

Please Read Carefully:

Information in this document is provided solely in connection with ST products. STMicroelectronics NV and its subsidiaries ("ST") reserve the right to make changes, corrections, modifications or improvements, to this document, and the products and services described herein at any time, without notice.

All ST products are sold pursuant to ST's terms and conditions of sale.

Purchasers are solely responsible for the choice, selection and use of the ST products and services described herein, and ST assumes no liability whatsoever relating to the choice, selection or use of the ST products and services described herein.

No license, express or implied, by estoppel or otherwise, to any intellectual property rights is granted under this document. If any part of this document refers to any third party products or services it shall not be deemed a license grant by ST for the use of such third party products or services, or any intellectual property contained therein or considered as a warranty covering the use in any manner whatsoever of such third party products or services or any intellectual property contained therein.

UNLESS OTHERWISE SET FORTH IN ST'S TERMS AND CONDITIONS OF SALE ST DISCLAIMS ANY EXPRESS OR IMPLIED WARRANTY WITH RESPECT TO THE USE AND/OR SALE OF ST PRODUCTS INCLUDING WITHOUT LIMITATION IMPLIED WARRANTIES OF MERCHANTABILITY, FITNESS FOR A PARTICULAR PURPOSE (AND THEIR EQUIVALENTS UNDER THE LAWS OF ANY JURISDICTION), OR INFRINGEMENT OF ANY PATENT, COPYRIGHT OR OTHER INTELLECTUAL PROPERTY RIGHT.

ST PRODUCTS ARE NOT DESIGNED OR AUTHORIZED FOR USE IN: (A) SAFETY CRITICAL APPLICATIONS SUCH AS LIFE SUPPORTING, ACTIVE IMPLANTED DEVICES OR SYSTEMS WITH PRODUCT FUNCTIONAL SAFETY REQUIREMENTS; (B) AERONAUTIC APPLICATIONS; (C) AUTOMOTIVE APPLICATIONS OR ENVIRONMENTS, AND/OR (D) AEROSPACE APPLICATIONS OR ENVIRONMENTS. WHERE ST PRODUCTS ARE NOT DESIGNED FOR SUCH USE, THE PURCHASER SHALL USE PRODUCTS AT PURCHASER'S SOLE RISK, EVEN IF ST HAS BEEN INFORMED IN WRITING OF SUCH USAGE, UNLESS A PRODUCT IS EXPRESSLY DESIGNATED BY ST AS BEING INTENDED FOR "AUTOMOTIVE, AUTOMOTIVE SAFETY OR MEDICAL" INDUSTRY DOMAINS ACCORDING TO ST PRODUCT DESIGN SPECIFICATIONS. PRODUCTS FORMALLY ESCC, QML OR JAN QUALIFIED ARE DEEMED SUITABLE FOR USE IN AEROSPACE BY THE CORRESPONDING GOVERNMENTAL AGENCY.

Resale of ST products with provisions different from the statements and/or technical features set forth in this document shall immediately void any warranty granted by ST for the ST product or service described herein and shall not create or extend in any manner whatsoever, any liability of ST.

ST and the ST logo are trademarks or registered trademarks of ST in various countries.

Information in this document supersedes and replaces all information previously supplied.

The ST logo is a registered trademark of STMicroelectronics. All other names are the property of their respective owners.

© 2013 STMicroelectronics - All rights reserved

STMicroelectronics group of companies

Australia - Belgium - Brazil - Canada - China - Czech Republic - Finland - France - Germany - Hong Kong - India - Israel - Italy - Japan - Malaysia - Malta - Morocco - Philippines - Singapore - Spain - Sweden - Switzerland - United Kingdom - United States of America

www.st.com