

## Product brief

# Sense2GoL development kit

24 GHz sensor development kit utilizing Infineon BGT24LTR11 RF transceiver and XMC1300 32-bit ARM® Cortex®-M0 MCU series

This development kit allows the user to implement and test several sensing applications at the 24 GHz ISM band such as Doppler based movement detection, Doppler based direction of movement detection, and Doppler based speed measurements of targets. The kit consists of the BGT24LTR11 transceiver MMIC and a XMC1300 32-bit ARM® Cortex®-M0 for signal processing and communication via USB.

A block diagram of the demonstrator board is shown in the figure below highlighting all main board components. The board is already preprogrammed using Infineon's DAVE™ development tool. The module features intermediate frequency amplification stages. A PLL is not needed on the board thanks to the integrated temperature compensation block in the RF MMIC. The MCU samples up to 2 IF channels of the transceiver chipset and communicates via USB interface to a connected PC. A provided PC application GUI (Windows based) can be used to display and analyze acquired data in time and frequency domain. The GUI allows for the extraction of the radar time domain signals allowing for advanced debugging and algorithm development.

### Applications

- > Security
- > Indoor lighting
- > Outdoor lighting
- > Smart home
- > Automatic door opener
- > Intelligent switches
- > Speed measurement
- > Health (vital sensing)

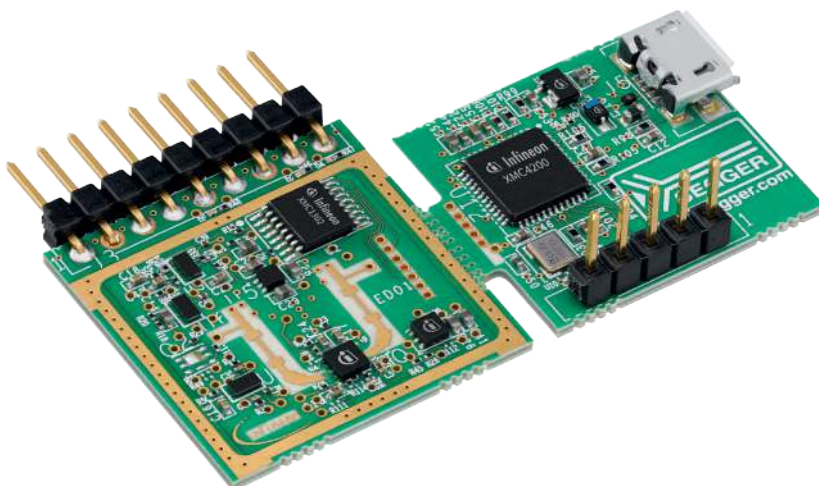

### Key features

- > Capability to detect motion, speed and direction of movement (approaching or retreating)
- > High sensitivity of detection in comparison to PIR
- > Operates in harsh environments and detects through non-metallic materials
- > Very small form-factor (2.5 cm × 2.5 cm) 24 GHz ISM band module that can be used as a development kit or mounted as a daughter board in a system
- > BGT24LTR11 – 24 GHz highly integrated RF MMIC
- > XMC1300 ARM® Cortex®-M0 – 32-bit industrial microcontroller
- > Debug over cortex 10 pin debug connector
- > Integrated multiple element patch antenna

### Contents of the kit

- > 24 GHz demo board
- > User's manual
- > SW GUI to operate kit
- > Schematic and Bill-of-Materials of module

### Features

- > Maximum distance: 15 m (human target)
- > Maximum speed: 20 km/h
- > Radar system field of view:
  - Horizontal: 29°
  - Vertical: 80°

# Sense2GoL development kit

24 GHz sensor development kit utilizing Infineon BGT24LTR11 RF transceiver and XMC1300 32-bit ARM® Cortex®-M0 MCU series

## Block diagram

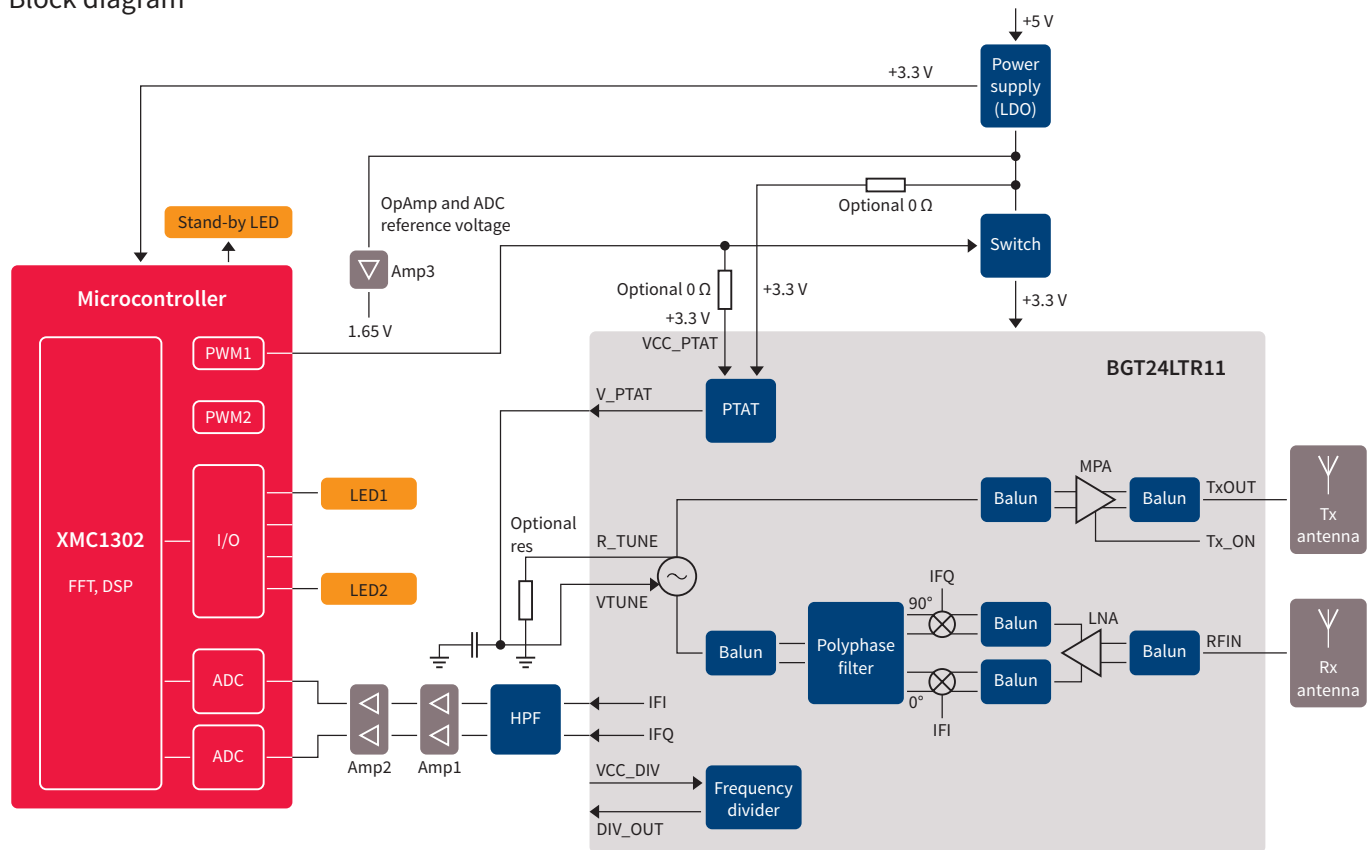

## Product summary

Type	Description	Ordering code (OPN)
Sense2GoL	24 GHz Doppler demonstration board	DEMOSENSE2GOLTOBO1
BGT24LTR11N16	24 GHz radar chip with 1 transmitter and 1 receiver in TSNP-16 package	BGT24LTR11N16E6327XTSA1
MC1302-T016X0032 AB	32-bit microcontrollers with ARM® Cortex®-M0 with focus on low-cost embedded control applications	XMC1302T016X0032ABXUMA1
IFX54211MB V33	Monolithic integrated fixed linear voltage regulator for load currents up to 150 mA	IFX54211MBV33HTSA1
IRLTS2242	-20 V single P-channel HEXFET power MOSFET in a TSOP-6 (Micro 6) package	IRLTS2242TRPBF
BAS3010A	Medium power AF schottky diode	BAS3010A03WE6327HTSA1
ESD8V0L2B-03L	Low capacitance TVS diode	ESD8V0L2B03LE6327XTMA1

Published by  
Infineon Technologies AG  
81726 Munich, Germany

© 2018 Infineon Technologies AG.  
All Rights Reserved.

### Please note!

THIS DOCUMENT IS FOR INFORMATION PURPOSES ONLY AND ANY INFORMATION GIVEN HEREIN SHALL IN NO EVENT BE REGARDED AS A WARRANTY, GUARANTEE OR DESCRIPTION OF ANY FUNCTIONALITY, CONDITIONS AND/OR QUALITY OF OUR PRODUCTS OR ANY SUITABILITY FOR A PARTICULAR PURPOSE. WITH REGARD TO THE TECHNICAL SPECIFICATIONS OF OUR PRODUCTS, WE KINDLY ASK YOU TO REFER TO THE RELEVANT PRODUCT DATA SHEETS PROVIDED BY US. OUR CUSTOMERS AND THEIR TECHNICAL DEPARTMENTS ARE REQUIRED TO EVALUATE THE SUITABILITY OF OUR PRODUCTS FOR THE INTENDED APPLICATION.

WE RESERVE THE RIGHT TO CHANGE THIS DOCUMENT AND/OR THE INFORMATION GIVEN HEREIN AT ANY TIME.

### Additional information

For further information on technologies, our products, the application of our products, delivery terms and conditions and/or prices, please contact your nearest Infineon Technologies office ([www.infineon.com](http://www.infineon.com)).

### Warnings

Due to technical requirements, our products may contain dangerous substances. For information on the types in question, please contact your nearest Infineon Technologies office.

Except as otherwise explicitly approved by us in a written document signed by authorized representatives of Infineon Technologies, our products may not be used in any life-endangering applications, including but not limited to medical, nuclear, military, life-critical or any other applications where a failure of the product or any consequences of the use thereof can result in personal injury.