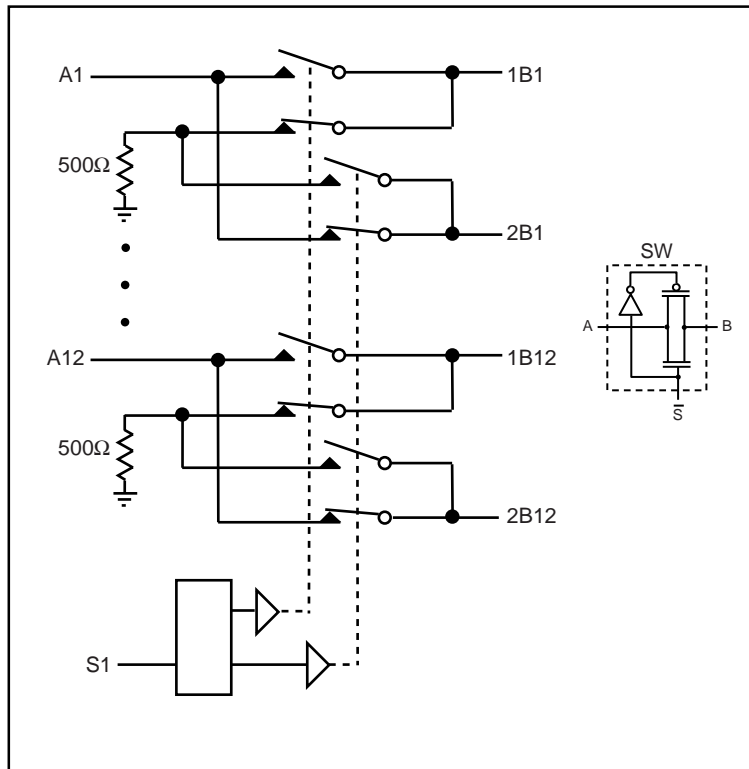
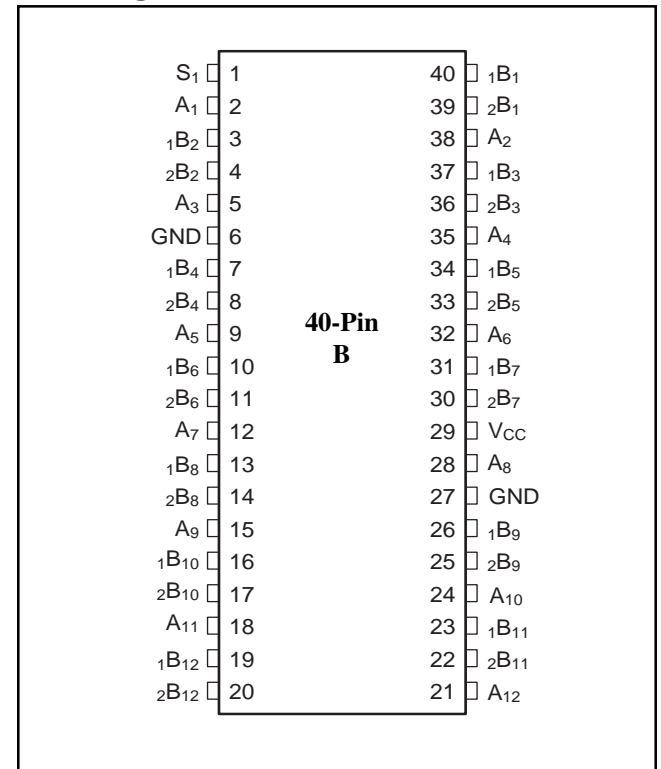

**Features**

- $R_{ON}$  is 5-ohm typical at 3.3V
- Low power: 10 $\mu$ W
- Industrial operating temperature: -40°C to +85°C
- Near zero propagation delay
- Fast switching speed: 4.5ns max.
- $V_{CC}$  operating range: 3.0V to 3.6V
- 500 -ohm pulldown to unconnected B port
- Series 25-ohm resistor option on all outputs
- Make-before-break action
- Packaging (Pb-free & Green available):  
-40-pin BQSOP (B)

**Description**

Pericom Semiconductor's PI3B16224 is a 3.3V, 12-bit to 24-bit mux/demux bus switch designed with a low On-Resistance allowing inputs to be connected directly to outputs.

**Block Diagram**

**Pin Configuration**

**Truth Table<sup>(1)</sup>**

Function	S1	A
A to 1B	L	1B
A to 2B	H	2B

### Maximum Ratings

(Above which useful life may be impaired. For user guidelines, not tested.)

Storage Temperature Range, T <sub>STG</sub> .....	-65°C to +150°C
Ambient Temperature with Power Applied .....	-40°C to +85°C
Supply Voltage Range, to Ground Potential .....	-0.5V to +4.6V
Input Voltage Range .....	-0.5V to +4.6V
DC Output Current .....	120mA
Power Dissipation .....	0.5W

**Note:**

Stresses greater than those listed under MAXIMUM RATINGS may cause permanent damage to the device. This is a stress rating only and functional operation of the device at these or any other conditions above those indicated in the operational sections of this specification is not implied. Exposure to absolute maximum rating conditions for extended periods may affect reliability.

### DC Electrical Characteristics (Over the Operating Range, T<sub>A</sub> = -40°C to +85°C, V<sub>CC</sub> = 3.0 to 3.6V)

Parameters	Description	Test Conditions <sup>(1)</sup>	Min.	Typ. <sup>(2)</sup>	Max.	Units
V <sub>IH</sub>	Input HIGH Voltage	Guaranteed Logic High Level	2.0			V
V <sub>IL</sub>	Input LOW Voltage	Guaranteed Logic Low Level	-0.5		0.8	
I <sub>IH</sub>	Input HIGH Current	V <sub>CC</sub> = Max.; V <sub>IN</sub> = V <sub>CC</sub>			±1	µA
I <sub>IL</sub>	Input LOW Current	V <sub>CC</sub> = Max.; V <sub>IN</sub> = GND			±1	
I <sub>OZH</sub>	High Impedance Output Current	0 ≤ A, B ≤ V <sub>CC</sub>			±1	
V <sub>IK</sub>	Clamp Diode Voltage	V <sub>CC</sub> = Min, I <sub>IN</sub> = -18mA		-0.7	-1.2	V
R <sub>ON</sub>	Switch On Resistance	V <sub>CC</sub> = Min., V <sub>IN</sub> = 0.0V, I <sub>ON</sub> = 12mA		5	8	Ω
R <sub>ON</sub>	Switch On Resistance	V <sub>CC</sub> = Min., V <sub>IN</sub> = 2.4V, I <sub>ON</sub> = 12mA		10	15	
C <sub>IN</sub>	Input Capacitance	V <sub>IN</sub> = 0V, 25°C, f = 1 MHz			3.0	pF
C <sub>ON</sub>	A/B Capacitance	V <sub>IN</sub> = 0V, 25°C, f = 1 MHz			25.0	
I <sub>CC</sub>	Power Supply Quiescent				10	µA

**Notes:**

1. Typical values are shown at V<sub>CC</sub> = 3.3V, +25°C ambient and maximum loading.

### Switching Electrical Characteristics (T<sub>A</sub> = -40°C to +85°C, V<sub>CC</sub> = 3.0 to 3.6V)

Parameters	Description	Test Conditions	PI3B16224		Units
			Com.		
			Min.	Max.	
t <sub>PLH</sub>	Propagation Delay Ax to xBx	C <sub>L</sub> = 50pF, R <sub>L</sub> = 500 ohms <sup>(1,2,3)</sup>	-	250	ps
t <sub>PE</sub>	Bus Enable	C <sub>L</sub> = 50pF, R <sub>L</sub> = 500 ohms <sup>(3)</sup>	1	4.5	ns
t <sub>PD</sub>	Bus Disable		1	5.0	
t <sub>M</sub>	Make-before-break time	C <sub>L</sub> = 50pF, R <sub>L</sub> = 500 ohms <sup>(1)</sup>	0	2	

**Notes:**

1. This parameter is guaranteed but not tested on Propagation Delays.
2. The bus switch contributes no propagational delay other than the RC delay of the ON resistance of the switch and the load capacitance. The time constant for the switch alone is of the order of 0.25ns for 50pF load. Since this time constant is much smaller than the rise/fall times of typical driving signals, it adds very little propagational delay to the system. Propagational delay of the bus switch when used in a system is determined by the driving circuit on the driving side of the switch and its interaction with the load on the driven side.
3. See test circuit and waveforms.

### Application Circuit

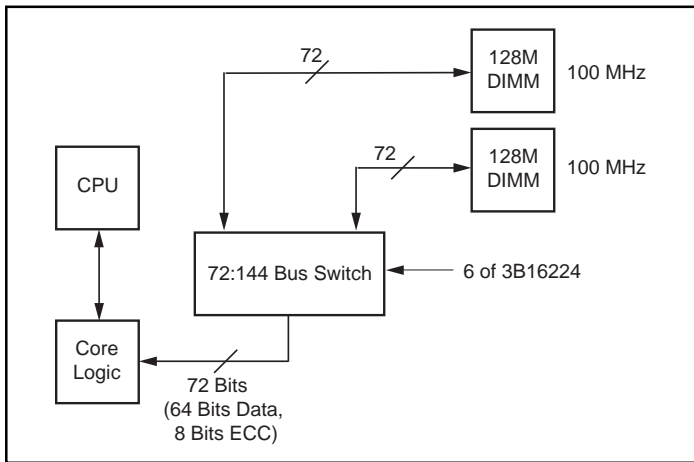

**Memory Switching Application**

### Application Information

#### Logic Inputs

The logic control inputs can be driven up to +3.6V regardless of the supply voltage. For example, given a +3.3V supply, IN may be driven LOW to 0V and HIGH to 3.6V. Driving IN Rail-to-Rail minimizes power consumption.

#### Power-Supply Sequencing and Hot Plug Information

Proper power-supply sequencing is advised for all CMOS devices. It is recommended to always apply V<sub>CC</sub> and GND before applying signals to the input/output or control pins.

*Rail-to-Rail is a registered trademark of Nippon Motorola, Ltd*

### Packaging Mechanical: 40-pin BQSOP (B)

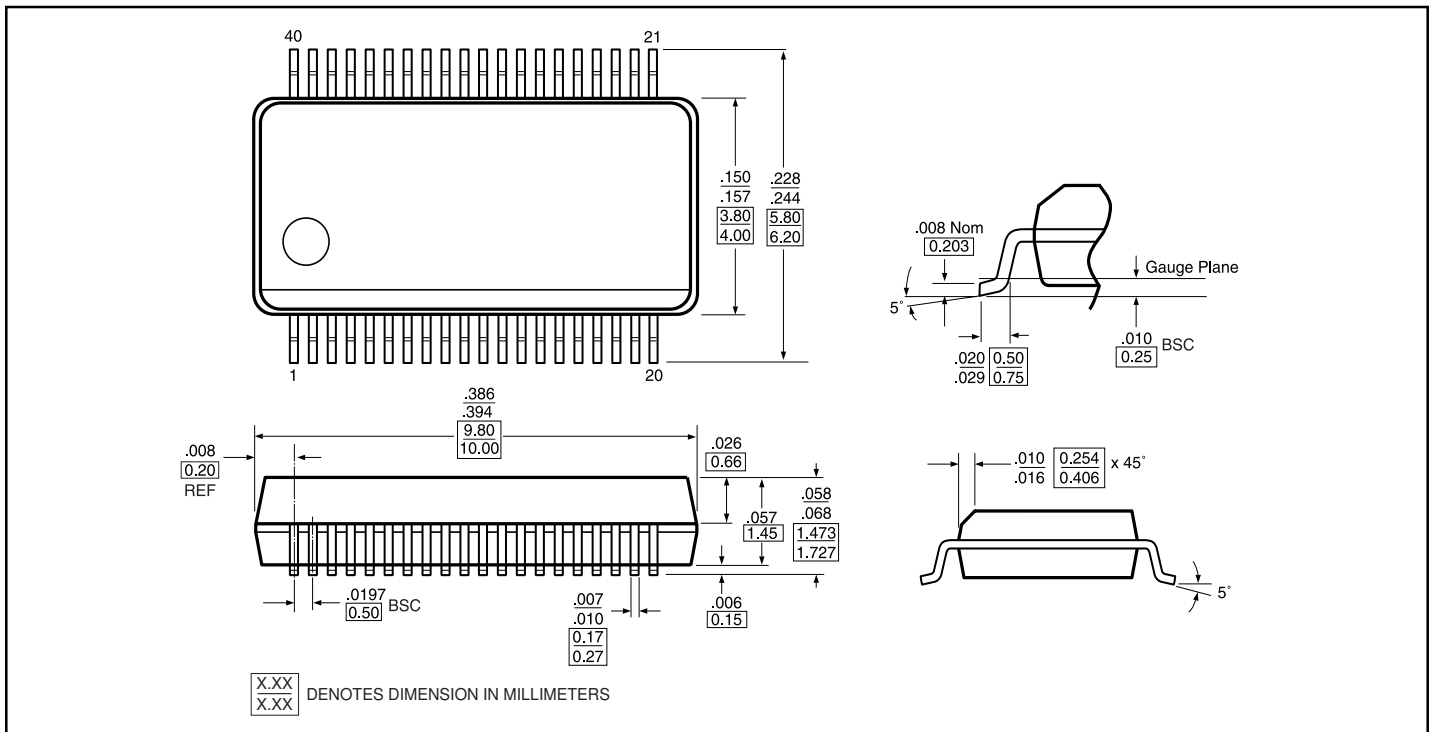

### Ordering Information

Ordering Code	Package Code	Package Description
PI3B16224B	B	40-pin BQSOP
PI3B16224BE	B	Pb-free & Green, 40-pin BQSOP

#### Notes:

1. Thermal Characteristics can be found on the world wide web at: [www.pericom.com/packaging/](http://www.pericom.com/packaging/)