

ergo-tek



Red Dot Design Award Winner 2014



Perfect synergy of Swiss precision and Italian design

Introducing Ergo-tek from Ideal-tek. New cutters and pliers handles' set a new benchmark in ergonomics. Following the User-Centered Design approach of one of the world's most respected research universities (University of Milan), over a two year period, Ideal-tek gained a full understanding of the needs, wants and frustrations of end users.

Subsequent painstaking attention to detail at every stage of the design process resulted in the creation of the ideal handles. The Swiss Precision approach provides quality, accuracy and longevity. The addition of Italian design brings beauty and elegance.

Ergo-tek. Perfect synergy.

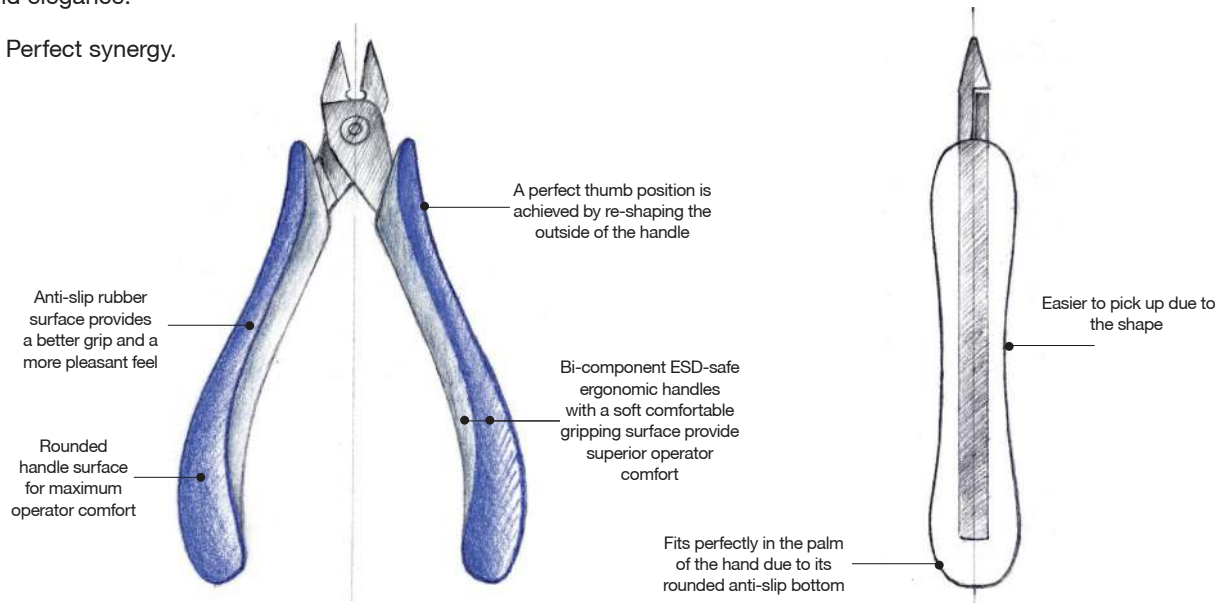

[click here to download the Paper Abstract \(ERGO-TEK\)](#)

Ergo-tek SLIM

THE NEW GENERATION ERGONOMIC HANDLES.



When Ideal-tek introduced the Ergo-tek range in 2013, we set a new benchmark for the ergonomics, quality, ESD safety standards and beauty of high precision cutters and pliers.

The new lighter weight **ERGO-TEK SLIM** range is designed especially for smaller hands while providing the same ergonomic, ESD-safe and technical advantages you expect from Ideal-tek.

Upgraded features:

- Revised ergonomic handle to provide enhanced operator comfort and reduce repetitive motion injuries
- Lighter weight
- Better accessibility and visibility in confined areas

With Ergo-tek AND Ergo-tek slim, users are now able to custom fit high precision tools to their personal preference and application.

No more, one line fits all!

[click here to download the Paper Abstract \(ERGO-TEK SLIM\)](#)



Handles

2-Component ESD-safe user-friendly Ergonomic handles with a soft comfortable gripping surface.

2 sizes: Ergo-tek (E) and Ergo-tek slim (ES)

For every handles production lot
Ideal-Tek performs the following tests:

- point to point resistance
- surface resistance
- decay time analysis



Material & Hardness

High quality ball bearing steel

- 45-48 Rockwell Hardness (HRC) for pliers
- 63 Rockwell Hardness for cutters

Pyrometer controlled inductive hardening

Superior no-scratch/antiglare satin finish

For every single production lot Ideal-Tek performs metallographic and hardness profile analysis.



Cutting Blades & Wire Definition

Cutting blades definition

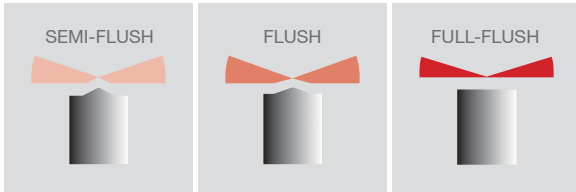

Wire definition

- SOFT wire, copper, aluminium, tensile strength 250 MPa
- MEDIUM-HARD wire, stainless steel wire, material 1.4301, tensile strength 800 MPa
- HARD wire, stainless steel wire, material 1.4301, tensile strength 1800 MPa

100% visual inspection



More Features

- Dual leaf springs made of stainless steel
- Lap joint with screw, to achieve a high level of strength and precision
- Nuts made of hardened alloy steel to resist high cutting load
- Perfect symmetry

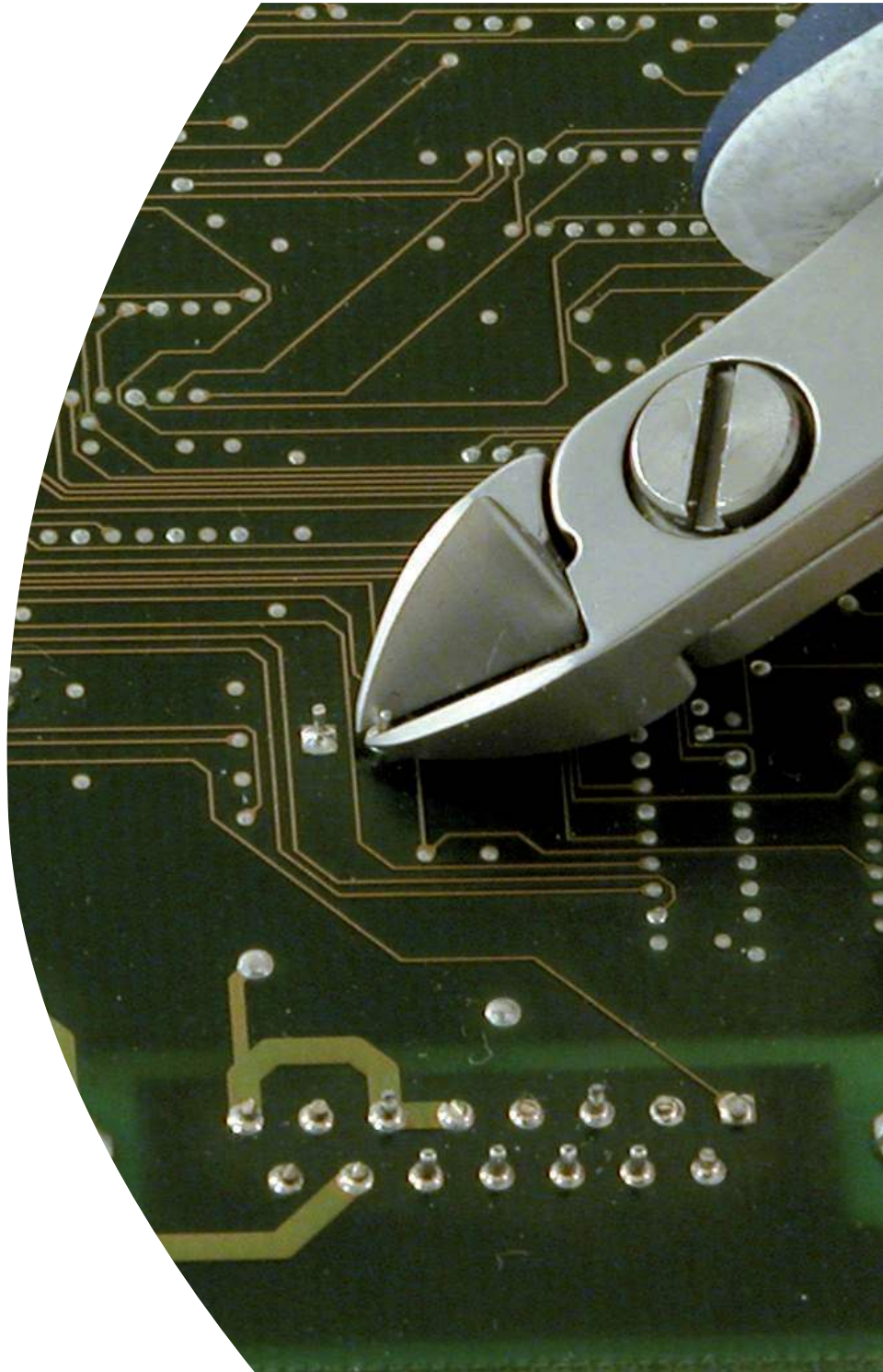

Free Test & Maintenance

The application engineering of the Ideal-Tek factory will conduct test cutting and cutting evaluations at no charge upon the receipt of test wire samples.

We also provide free cutter model recommendations.

In order to preserve your cutters perfectly efficient keep a thin oil film on the tips head.



[click here to see the maintenance \(VIDEO\)](#)

Head Shape & Available models

CUTTERS

- Oval
- Tapered
- Tapered & Relieved
- Wire Lead Catchers
- Special

PLIERS

- Snipe Nose
- Flat & Round Nose



Oval Cutters



reddot design award

Small robust, slim shape, and optimum balance between durability and accessibility.

Large strong and durable, for intensive cutting operations.

Extra-Large Rounded extremely strong and durable with rounded head, for intensive cutting operations.



5140-41-42



5150-51-52



5160L-61L-62L

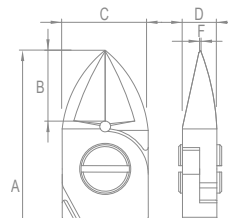
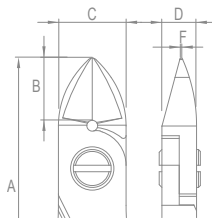
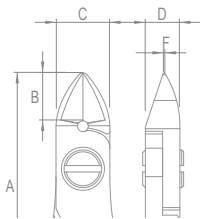

CUTTING CAPACITY

Art. No.	Type	A	B	C	D	F	Cutting Edges	Soft		Medium		Hard	
								(mm/Inch)	(AWG)	(mm/Inch)	(AWG)	(mm/Inch)	(AWG)
ES5140	Small	120 mm 5.04"	10 mm 0.39"	10 mm 0.39"	6.4 mm 0.25"	0.5 mm 0.02"	Semi-Flush	0.2-1.2 mm 0.008"- 0.05"	32-17	0.1-1.0 mm 0.004"- 0.04"	38-18	0.03-0.6 mm 0.001"- 0.02"	48-23
ES5141	Small	120 mm 5.04"	10 mm 0.39"	10 mm 0.39"	6.4 mm 0.25"	0.5 mm 0.02"	Flush	0.1-1.2 mm 0.004"- 0.05"	38-17	0.1-1.0 mm 0.004"- 0.04"	38-18	-	-
ES5142	Small	120 mm 5.04"	10 mm 0.39"	10 mm 0.39"	6.4 mm 0.25"	0.5 mm 0.02"	Full-Flush	0.1-1.0 mm 0.004"- 0.04"	38-18	0.1-0.8 mm 0.004"- 0.03"	38-20	-	-
ES5150	Large	120 mm 5.04"	12.5 mm 0.49"	12.5 mm 0.49"	6.4 mm 0.25"	0.5 mm 0.02"	Semi-Flush	0.3-1.6 mm 0.012"- 0.06"	29-14	0.1-1.3 mm 0.004"- 0.05"	38-16	0.03-0.7 mm 0.001"- 0.03"	48-21
ES5151	Large	120 mm 5.04"	12.5 mm 0.49"	12.5 mm 0.49"	6.4 mm 0.25"	0.5 mm 0.02"	Flush	0.2-1.6 mm 0.008"- 0.06"	32-14	0.1-1.2 mm 0.004"- 0.047"	38-17	-	-
ES5152	Large	120 mm 5.04"	12.5 mm 0.49"	12.5 mm 0.49"	6.4 mm 0.25"	0.5 mm 0.02"	Full-Flush	0.2-1.2 mm 0.008"- 0.047"	32-17	0.1-1.0 mm 0.004"- 0.04"	38-18	-	-
ES5160L	Extra Large Rounded	125 mm 4.92"	14 mm 0.55"	16 mm 0.63"	6.4 mm 0.25"	0.5 mm 0.02"	Semi-Flush	0.5-3.0 mm 0.019"- 0.12"	24-09	0.4-2.5 mm 0.015"- 0.10"	26-10	0.03-1.1 mm 0.001"- 0.04"	42-17
ES5161L	Extra Large Rounded	125 mm 4.92"	14 mm 0.55"	16 mm 0.63"	6.4 mm 0.25"	0.5 mm 0.02"	Flush	0.4-2.5 mm 0.015"- 0.10"	26-10	0.4-2.3 mm 0.015"- 0.09"	26-11	-	-
ES5162L	Extra Large Rounded	125 mm 4.92"	14 mm 0.55"	16 mm 0.63"	6.4 mm 0.25"	0.5 mm 0.02"	Full-Flush	0.4-2.5 mm 0.015"- 0.10"	26-10	0.4-2.0 mm 0.015"- 0.08"	26-12	-	-

Tapered Cutters



Small pointed head shape, slim and optimum balance between durability and accessibility.

Large robust and versatile, pointed head shape to increase accessibility when limited space.



5340-41-42



5350-51-52

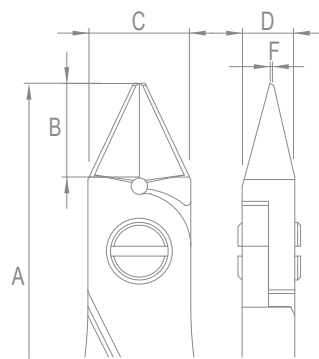
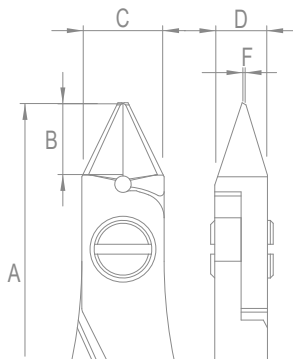

CUTTING CAPACITY

Art. No.	Type	A	B	C	D	F	Cutting Edges	Soft		Medium		Hard	
								(mm/Inch)	(AWG)	(mm/Inch)	(AWG)	(mm/Inch)	(AWG)
ES5340	Small	120 mm 5.04"	10 mm 0.39"	10 mm 0.39"	6.4 mm 0.25"	0.5 mm 0.02"	Semi-Flush	0.2-1.2 mm 0.008"- 0.05"	32-17	0.1-1.0 mm 0.004"- 0.04"	38-18	0.03-0.6 mm 0.001"- 0.02"	48-23
ES5341	Small	120 mm 5.04"	10 mm 0.39"	10 mm 0.39"	6.4 mm 0.25"	0.5 mm 0.02"	Flush	0.1-1.2 mm 0.004"- 0.05"	38-17	0.1-1.0 mm 0.004"- 0.04"	38-18	-	-
ES5342	Small	120 mm 5.04"	10 mm 0.39"	10 mm 0.39"	6.4 mm 0.25"	0.5 mm 0.02"	Full-Flush	0.1-1.0 mm 0.004"- 0.04"	38-18	0.1-0.8 mm 0.004"- 0.03"	38-20	-	-
ES5350	Large	120 mm 5.04"	12.5 mm 0.49"	12.5 mm 0.49"	6.4 mm 0.25"	0.5 mm 0.02"	Semi-Flush	0.3-1.6 mm 0.012"- 0.06"	29-14	0.1-1.2 mm 0.004"- 0.047"	38-17	0.03-0.7 mm 0.001"- 0.03"	48-21
ES5351	Large	120 mm 5.04"	12.5 mm 0.49"	12.5 mm 0.49"	6.4 mm 0.25"	0.5 mm 0.02"	Flush	0.2-1.6 mm 0.008"- 0.06"	32-14	0.1-1.1 mm 0.004"- 0.04"	38-18	-	-
ES5352	Large	120 mm 5.04"	12.5 mm 0.49"	12.5 mm 0.49"	6.4 mm 0.25"	0.5 mm 0.02"	Full-Flush	0.2-1.2 mm 0.008"- 0.047"	32-17	0.1-1.0 mm 0.004"- 0.04"	38-18	-	-

Tapered & Relieved Cutters



Small pointed head shape and deep relief for a very low profile to maximize accessibility when limited space.



5540-41-42

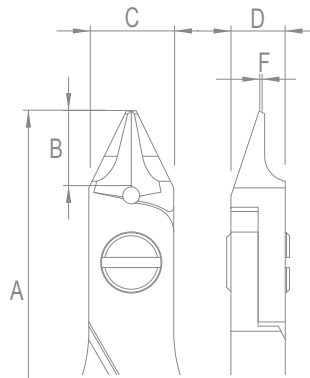

CUTTING CAPACITY

Art. No.	Type	A	B	C	D	F	Cutting Edges	Soft		Medium		Hard	
								(mm/Inch)	(AWG)	(mm/Inch)	(AWG)	(mm/Inch)	(AWG)
ES5540	Small	120 mm 5.04"	10 mm 0.39"	10 mm 0.39"	6.4 mm 0.25"	0.5 mm 0.02"	Semi-Flush	0.2-1.2 mm 0.008"- 0.05"	32-17	0.1-1.0 mm 0.004"- 0.04"	38-18	-	-
ES5541	Small	120 mm 5.04"	10 mm 0.39"	10 mm 0.39"	6.4 mm 0.25"	0.5 mm 0.02"	Flush	0.1-1.2 mm 0.004"- 0.05"	38-17	0.1-0.4 mm 0.004"- 0.015"	38-26	-	-
ES5542	Small	120 mm 5.04"	10 mm 0.39"	10 mm 0.39"	6.4 mm 0.25"	0.5 mm 0.02"	Full-Flush	0.1-0.8 mm 0.004"- 0.03"	38-20	0.1-0.4 mm 0.004"- 0.015"	38-26	-	-

Wire Lead Catcher



Wire Lead Catcher, made of stainless steel AISI 304, for our high precision cutters with 10mm box or 12,5mm box.

Wire Lead Catcher fits Oval, Tapered and Tapered & Relieved cutters only.

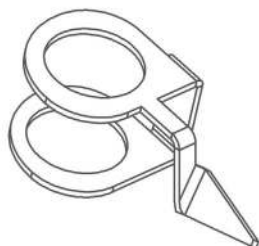

Art. No.	Type	Description
WLC100	Small	100 pcs • for cutters with box joint of 10 mm (0.39")
WLC125	Large	100 pcs • for cutters with box joint of 12.5 mm (0.49")

[click here to see the plug&play system \(VIDEO\)](#)

Oblique Head Cutters



A. Angulated cutters to maximize accessibility and visibility when limited space.

B. Angulated and robust.



**A - Oblique Head Small
5247**



**B - Oblique Head Large
5250**

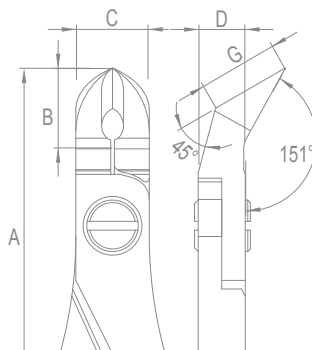
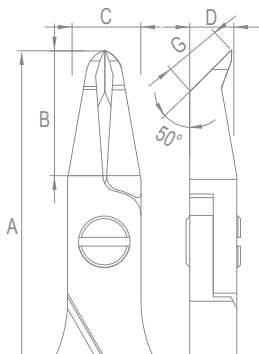

CUTTING CAPACITY

Art. No.	Type	A	B	C	D	G	Cutting Edges	Soft		Medium		Hard	
								(mm/Inch)	(AWG)	(mm/Inch)	(AWG)	(mm/Inch)	(AWG)
ES5247	Oblique Head Small	125 mm 4.92"	17 mm 0.67"	10 mm 0.39"	6.4 mm 0.25"	8 mm 0.31"	Full-Flush	0.1-1.2 mm 0.004"- 0.047"	38-17	0.1-0.6 mm 0.004"- 0.02"	38-23	-	-
ES5250	Oblique Head Large	125 mm 4.92"	14.5 mm 0.57"	10 mm 0.39"	6.4 mm 0.25"	11 mm 0.43"	Flush	0.2-1.2 mm 0.008"- 0.05"	32-17	0.1-1.0 mm 0.004"- 0.04"	38-18	-	-

Snipe Nose Pliers



Commonly used in electronic assembly and rework, as well as in fine jewellery



6021-22

6023-24
6023S-24S

6023B

6025

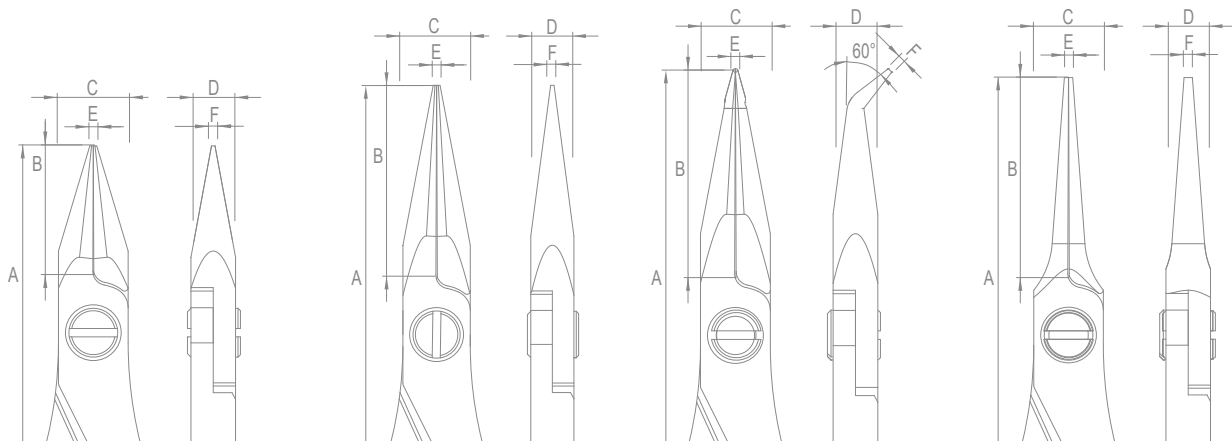

Art. No.	Type	A	B	C	D	E	F	Jaw Shape
ES6021	Snipe Nose	130 mm 5.12"	20 mm 0.79"	10 mm 0.39"	6.4 mm 0.25"	1 mm 0.04"	0.5 mm 0.02"	Smooth
ES6022	Snipe Nose	130 mm 5.12"	20 mm 0.79"	10 mm 0.39"	6.4 mm 0.25"	1 mm 0.04"	0.5 mm 0.02"	Serrated
ES6023	Snipe Nose Long	140 mm 5.51"	30 mm 1.18"	10 mm 0.39"	6.4 mm 0.25"	1 mm 0.04"	0.5 mm 0.02"	Smooth
ES6023S	Snipe Nose Strong	135 mm 5.31"	28 mm 1.10"	10 mm 0.39"	6.4 mm 0.25"	1.8 mm 0.07"	1.6 mm 0.06"	Smooth
ES6023B	Bent Nose	140 mm 5.31"	30 mm 1.18"	10 mm 0.39"	6.4 mm 0.25"	1 mm 0.04"	0.5 mm 0.02"	Smooth
ES6024	Snipe Nose Long	140 mm 5.51"	30 mm 1.18"	10 mm 0.39"	6.4 mm 0.25"	1 mm 0.04"	0.5 mm 0.02"	Serrated
ES6024S	Snipe Nose Strong	135 mm 5.31"	28 mm 1.10"	10 mm 0.39"	6.4 mm 0.25"	1.8 mm 0.07"	1.6 mm 0.06"	Serrated
ES6025	Needle Nose	140 mm 5.51"	30 mm 1.18"	10 mm 0.39"	6.4 mm 0.25"	1.3 mm 0.05"	1.3 mm 0.05"	Smooth

TECHNICAL DATA SHEET

Flat & Round Nose Pliers



reddot design award

A. - B. Flat nose pliers feature a very fine tip, smooth or serrated jaws and inner edges.

C. Round nose pliers have jaws formed by two cones. A round nose pliers is generally used both to clamp and to form loops on leads or wire.



A - Flat Nose
6011-12



B - Flat Nose long
6013-14



C - Round Nose
6041

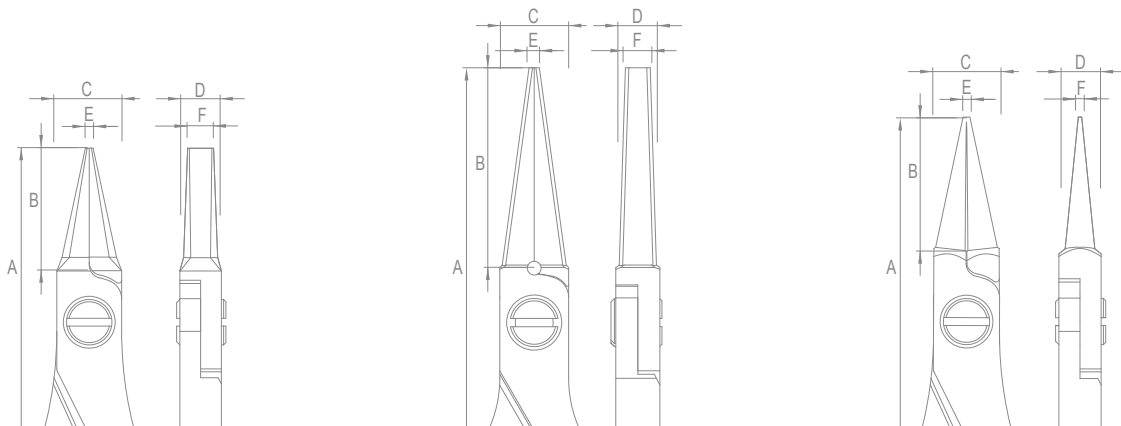

Art. No.	Type	A	B	C	D	E	F	Jaw Shape
ES6011	Flat Nose	130 mm 5.12"	20 mm 0.79"	10 mm 0.39"	6.4 mm 0.25"	1.2 mm 0.05"	4 mm 0.16"	Smooth
ES6012	Flat Nose	130 mm 5.12"	20 mm 0.79"	10 mm 0.39"	6.4 mm 0.25"	1.2 mm 0.05"	4 mm 0.16"	Serrated
ES6013	Flat Nose Long	140 mm 5.31"	30 mm 1.18"	10 mm 0.39"	6.4 mm 0.25"	1.5 mm 0.06"	3.6 mm 0.14"	Smooth
ES6014	Flat Nose Long	140 mm 5.31"	30 mm 1.18"	10 mm 0.39"	6.4 mm 0.25"	1.5 mm 0.06"	3.6 mm 0.14"	Serrated
ES6041	Round Nose	135 mm 5.31"	24	10 mm 0.39"	6.4 mm 0.25"	1 mm 0.04"	0.5 mm 0.02"	Smooth

Contacts

Mail address

Ideal-tek SA · p.o. box 17
6830 Chiasso · Switzerland

Shipping address

Ideal-tek SA · via Motta 4
6828 Balerna · Switzerland

Phone +41 91 683 32 29

Fax +41 91 683 03 71

E-mail info@ideal-tek.com

Web www.ideal-tek.com

