

SOLENOID PRODUCT SPECIFICATION

PART No.	VOLTAGE	DUTY CYCLE	POWER (W)	CURRENT (A)	DCR (Ω) *
DSOL-0630-05C	5 VDC	100%	4	0.8	6
DSOL-0630-05E	5 VDC	25%, 60sec On	8.2	1.6	3.2
DSOL-0630-12C	12 VDC	100%	4	0.4	36
DSOL-0630-12E	12 VDC	25%, 60sec On	8.5	0.7	17
DSOL-0630-18C	18 VDC	100%	4.8	0.27	66
DSOL-0630-18E	18 VDC	25%, 60sec On	8.5	0.48	38
DSOL-0630-24C	24 VDC	100%	4	0.2	144
DSOL-0630-24E	24 VDC	25%, 60sec On	8.5	0.4	68

* OPERATION: POWER TO PULL , NO RETURN SPRING.

* DCR VALUES ARE ±10% AT 25°C

* WEIGHT ARE 80 GRAMS ±10%

1. MECHANICAL DIMENSIONS :

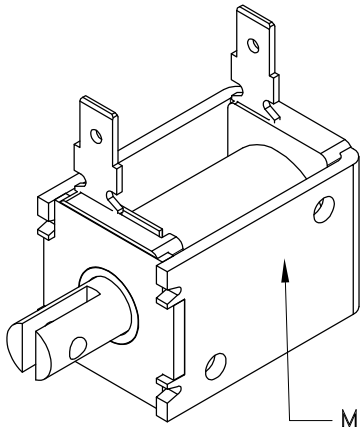

MARKING
 DSOL-0630-xxx
 DECTYYWWA DDLL

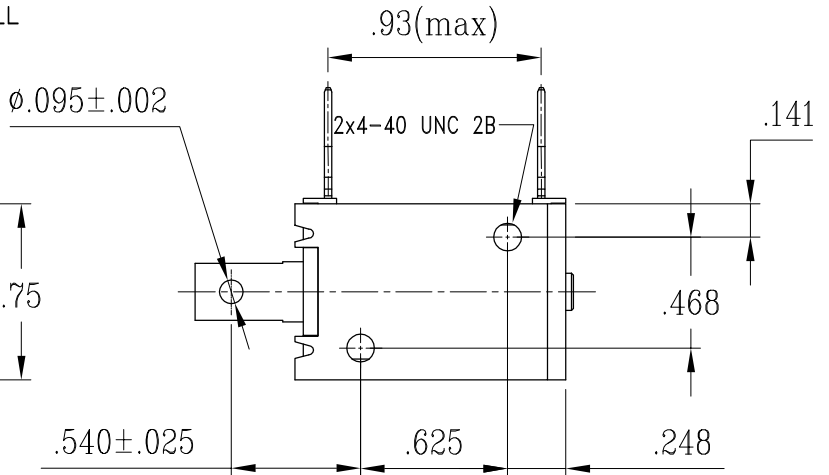
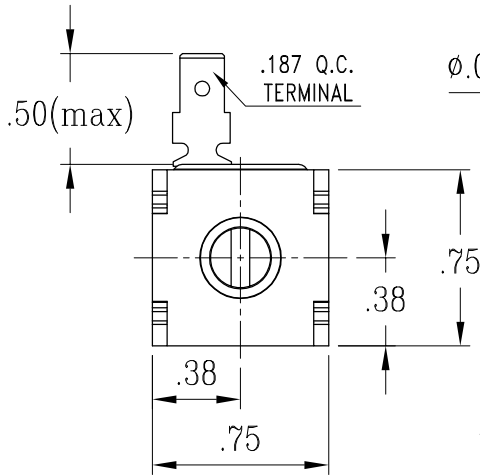
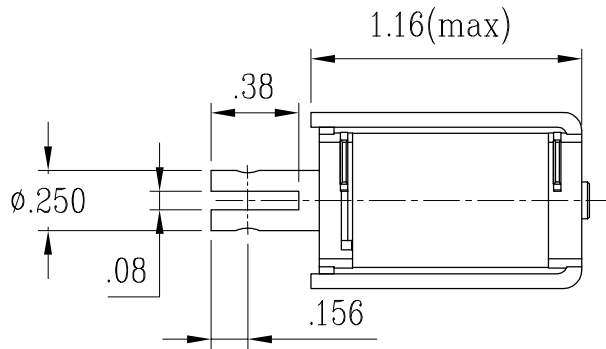

2. SCHEMATIC AND CONSTRUCTION :

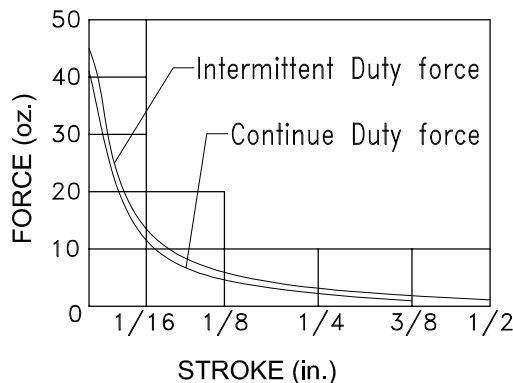
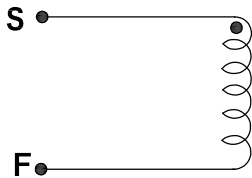

UNIT : inch.

UNLESS TOLERANCES.

XX = ±0.02

XX.X = ±0.01

ANGLES = ±1°

INSULATION MATERIALS: UL CONSTRUCTION, CLASS B 130°C
 LIFE EXPECTANCY: 100K CYCLES OPERATIONS

LAYER TEST	IR. @500 Vdc.	HI-POT
(S-F) 500Vp. MIN.	COIL TO FRAME	⑤50/60Hz.,2mA
TEST ONLY COIL	50 MOHM MIN.	COIL TO FRAME
		1200Vac.,1s