

Mechanical Dimensions: Inches [mm]

Tolerances ± 0.012 [0.3] Unless Otherwise Specified

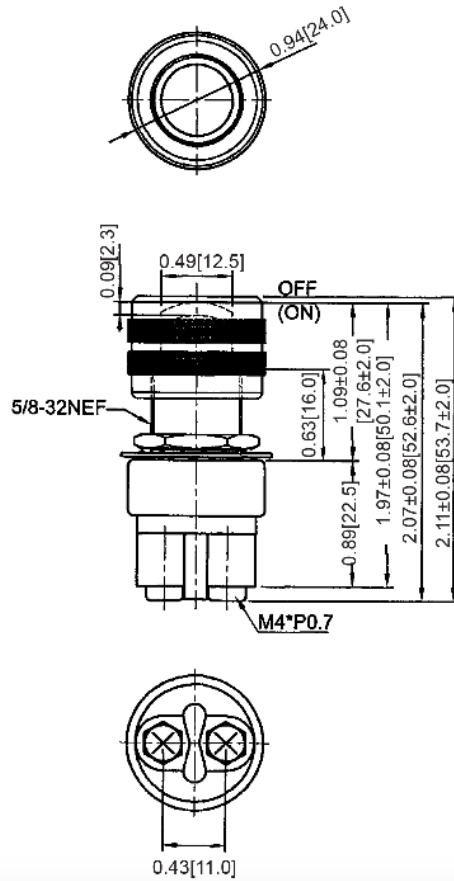

Mounting Hole

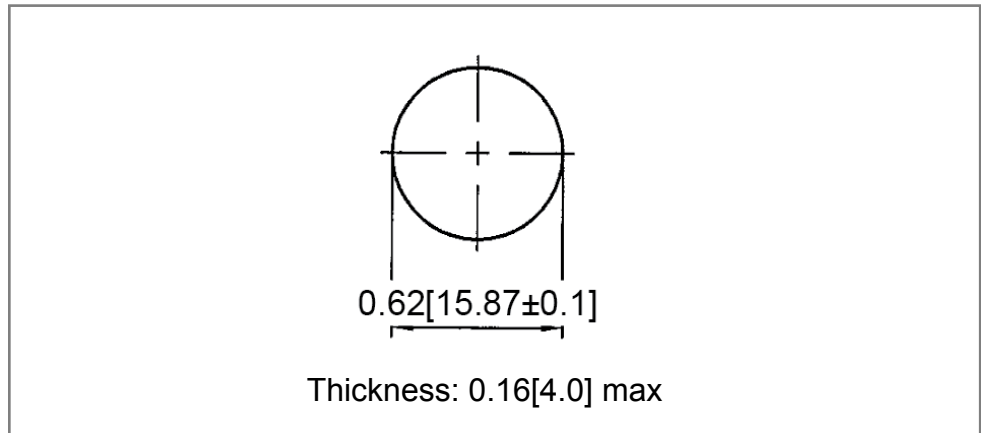

Circuit Diagram

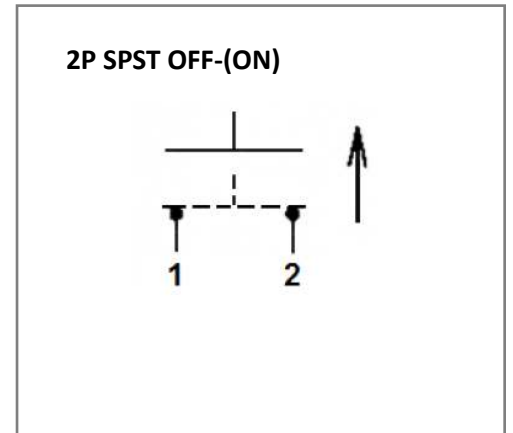

Electrical Specifications

Rating	60A max 12VDC
Contact Resistance	50m ohm Max
Insulation Resistance	DC 500V 100M ohm Min
Dielectric Strength	AC 1500V 1 minute
Operation Temperature	

Material Specifications

Housing	Zinc Alloy
Base	Black, Nylon#66
Ton	Black, Nylon#66
	1 Tube Nut Assy
	1 Hex Nut Assy
	1 Locker Washer Assy

Rev	Date of issue	Revision Notes	Designed	Approved
B	04-15-2020	Initial Drawing	RC	OF