

# 1-Mbit (64K x 18) Flow-Through Sync SRAM

## Features

- 64K x 18 common I/O
- 3.3V core power supply ( $V_{DD}$ )
- 2.5V/3.3V I/O power supply ( $V_{DDQ}$ )
- Fast clock-to-output times  
— 6.5 ns (for 133-MHz version)
- Provide high-performance 2-1-1 access rate
- User-selectable burst counter supporting Intel® Pentium® interleaved or linear burst sequences
- Separate processor and controller address strobes
- Synchronous self-timed write
- Asynchronous output enable
- Available in JEDEC-standard lead-free 100-Pin TQFP package
- “ZZ” Sleep Mode option

## Functional Description<sup>[1]</sup>

The CY7C1297H is a 64K x 18 synchronous cache RAM designed to interface with high-speed microprocessors with minimum glue logic. Maximum access delay from clock rise is 6.5 ns (133-MHz version). A 2-bit on-chip counter captures the first address in a burst and increments the address automatically for the rest of the burst access. All synchronous inputs are gated by registers controlled by a positive-edge-triggered Clock Input (CLK). The synchronous inputs include all addresses, all data inputs, address-pipelining Chip Enable ( $\overline{CE}_1$ ), depth-expansion Chip Enables ( $\overline{CE}_2$  and  $\overline{CE}_3$ ), Burst Control inputs (ADSC, ADSP, and ADV), Write Enables ( $BW_{[A:B]}$ , and BWE), and Global Write (GW). Asynchronous inputs include the Output Enable ( $\overline{OE}$ ) and the ZZ pin.

The CY7C1297H allows either interleaved or linear burst sequences, selected by the MODE input pin. A HIGH selects an interleaved burst sequence, while a LOW selects a linear burst sequence. Burst accesses can be initiated with the Processor Address Strobe (ADSP) or the cache Controller Address Strobe (ADSC) inputs. Address advancement is controlled by the Address Advancement (ADV) input.

Addresses and chip enables are registered at rising edge of clock when either Address Strobe Processor (ADSP) or Address Strobe Controller (ADSC) are active. Subsequent burst addresses can be internally generated as controlled by the Advance pin (ADV).

The CY7C1297H operates from a +3.3V core power supply while all outputs may operate either with a +2.5V or +3.3V supply. All inputs and outputs are JEDEC-standard JESD8-5-compatible.

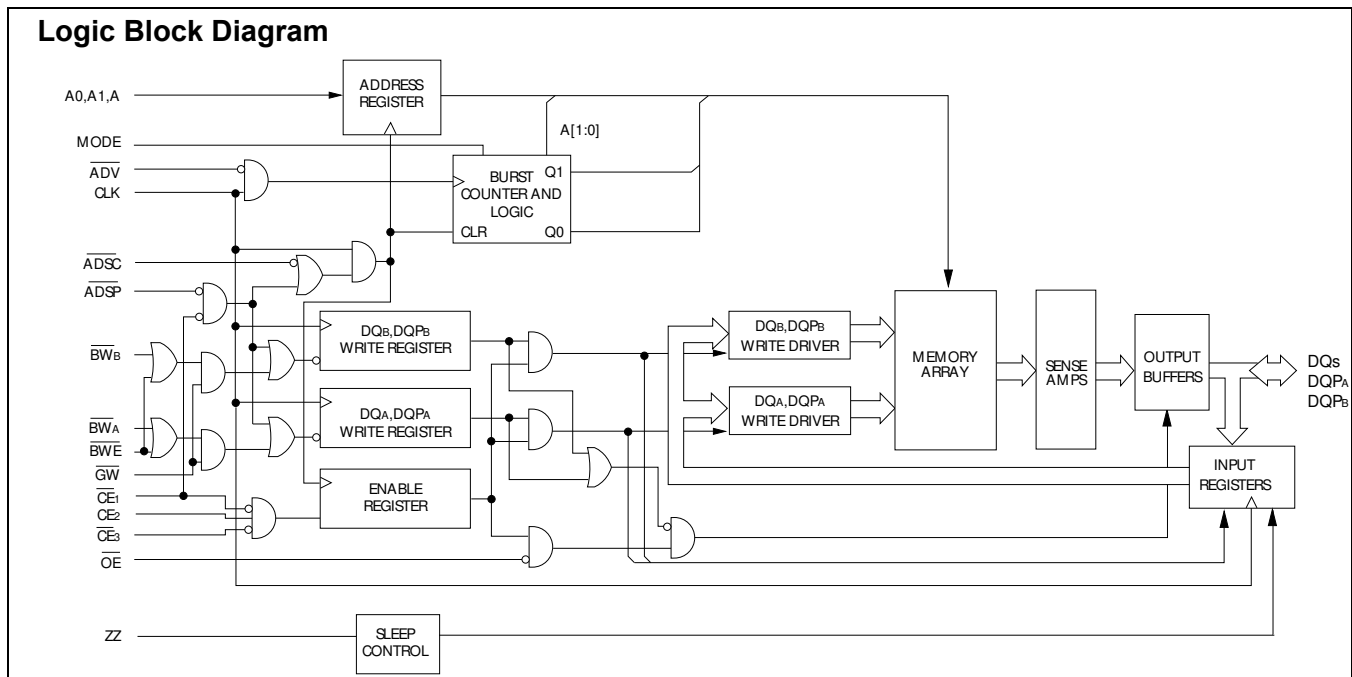

**Note:**

1. For best-practices recommendations, please refer to the Cypress application note *System Design Guidelines* on [www.cypress.com](http://www.cypress.com).

**Selection Guide**

	133 MHz	100 MHz	Unit
Maximum Access Time	6.5	8.0	ns
Maximum Operating Current	225	205	mA
Maximum Standby Current	40	40	mA

**Pin Configuration**

**100-Pin TQFP**

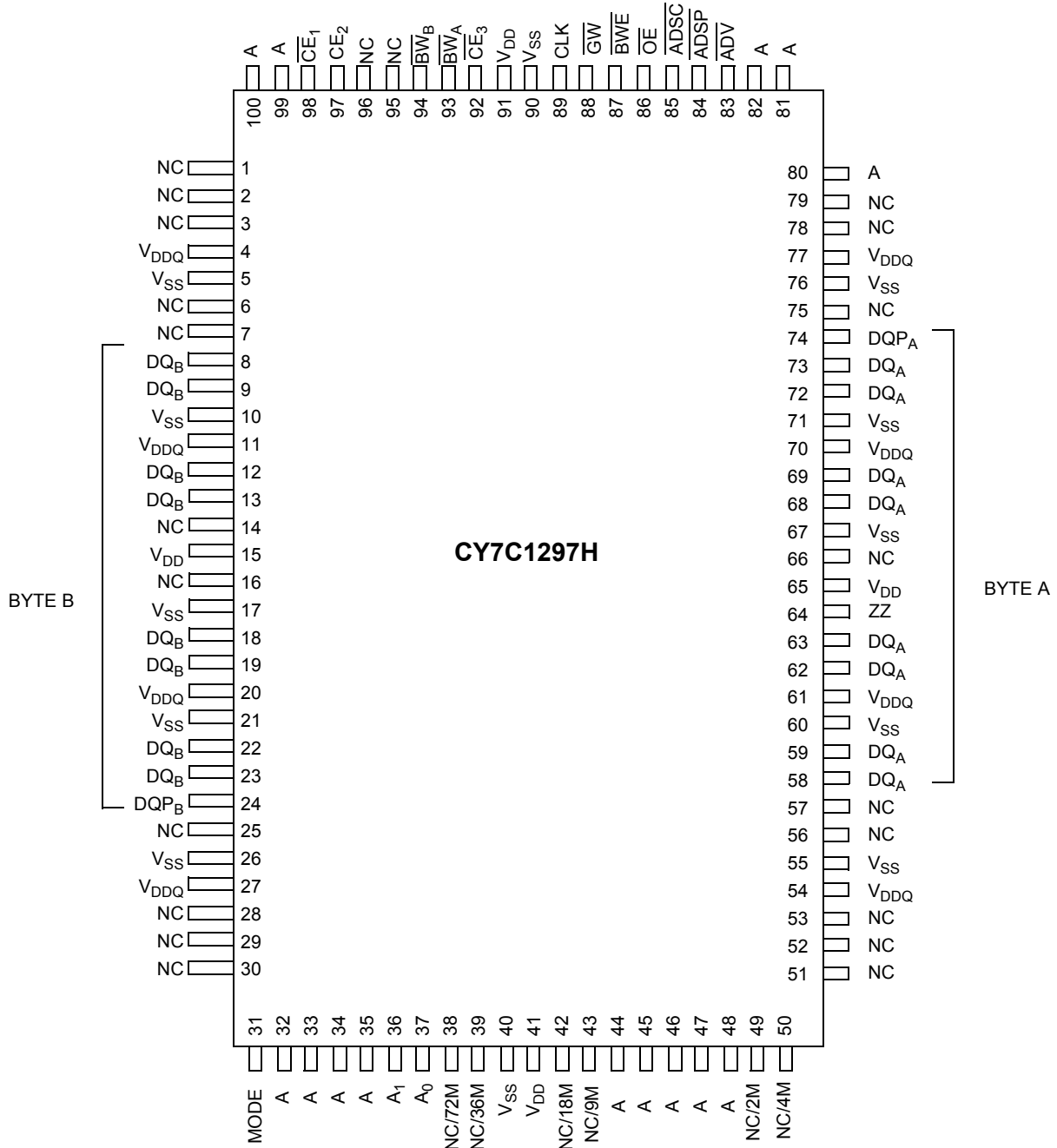

**Pin Descriptions**

Name	I/O	Description
A0, A1, A	Input-Synchronous	<b>Address Inputs used to select one of the 64K address locations.</b> Sampled at the rising edge of the CLK if ADSP or ADSC is active LOW, and CE <sub>1</sub> , CE <sub>2</sub> , and CE <sub>3</sub> are sampled active. A <sub>[1:0]</sub> feed the 2-bit counter.
$\overline{BW}_A$ , $\overline{BW}_B$	Input-Synchronous	<b>Byte Write Select Inputs, active LOW.</b> Qualified with $\overline{BWE}$ to conduct Byte Writes to the SRAM. Sampled on the rising edge of CLK.
$\overline{GW}$	Input-Synchronous	<b>Global Write Enable Input, active LOW.</b> When asserted LOW on the rising edge of CLK, a global Write is conducted (ALL bytes are written, regardless of the values on $\overline{BW}_{[A:B]}$ and BWE).
BWE	Input-Synchronous	<b>Byte Write Enable Input, active LOW.</b> Sampled on the rising edge of CLK. This signal must be asserted LOW to conduct a Byte Write.
CLK	Input-Clock	<b>Clock Input.</b> Used to capture all synchronous inputs to the device. Also used to increment the burst counter when ADV is asserted LOW, during a burst operation.
CE <sub>1</sub>	Input-Synchronous	<b>Chip Enable 1 Input, active LOW.</b> Sampled on the rising edge of CLK. Used in conjunction with CE <sub>2</sub> and CE <sub>3</sub> to select/deselect the device. ADSP is ignored if CE <sub>1</sub> is HIGH. CE <sub>1</sub> is sampled only when a new external address is loaded.
CE <sub>2</sub>	Input-Synchronous	<b>Chip Enable 2 Input, active HIGH.</b> Sampled on the rising edge of CLK. Used in conjunction with CE <sub>1</sub> and CE <sub>3</sub> to select/deselect the device. CE <sub>2</sub> is sampled only when a new external address is loaded.
CE <sub>3</sub>	Input-Synchronous	<b>Chip Enable 3 Input, active LOW.</b> Sampled on the rising edge of CLK. Used in conjunction with CE <sub>1</sub> and CE <sub>2</sub> to select/deselect the device. CE <sub>3</sub> is sampled only when a new external address is loaded.
OE	Input-Asynchronous	<b>Output Enable, asynchronous input, active LOW.</b> Controls the direction of the I/O pins. When LOW, the I/O pins behave as outputs. When deasserted HIGH, I/O pins are tri-stated, and act as input data pins. OE is masked during the first clock of a Read cycle when emerging from a deselected state.
ADV	Input-Synchronous	<b>Advance Input signal, sampled on the rising edge of CLK.</b> When asserted, it automatically increments the address in a burst cycle.
ADSP	Input-Synchronous	<b>Address Strobe from Processor, sampled on the rising edge of CLK, active LOW.</b> When asserted LOW, addresses presented to the device are captured in the address registers. A <sub>[1:0]</sub> are also loaded into the burst counter. When ADSP and ADSC are both asserted, only ADSP is recognized. ADSP is ignored when CE <sub>1</sub> is deasserted HIGH.
ADSC	Input-Synchronous	<b>Address Strobe from Controller, sampled on the rising edge of CLK, active LOW.</b> When asserted LOW, addresses presented to the device are captured in the address registers. A <sub>[1:0]</sub> are also loaded into the burst counter. When ADSP and ADSC are both asserted, only ADSP is recognized.
ZZ	Input-Asynchronous	<b>ZZ "Sleep" Input, active HIGH.</b> When asserted HIGH places the device in a non-time-critical "sleep" condition with data integrity preserved. For normal operation, this pin has to be LOW or left floating. ZZ pin has an internal pull-down.
DQs DQP <sub>A</sub> , DQP <sub>B</sub>	I/O-Synchronous	<b>Bidirectional Data I/O lines.</b> As inputs, they feed into an on-chip data register that is triggered by the rising edge of CLK. As outputs, they deliver the data contained in the memory location specified by the addresses presented during the previous clock rise of the Read cycle. The direction of the pins is controlled by OE. When OE is asserted LOW, the pins behave as outputs. When HIGH, DQs and DQP <sub>[A:B]</sub> are placed in a tri-state condition.
V <sub>DD</sub>	Power Supply	<b>Power supply inputs to the core of the device.</b>
V <sub>SS</sub>	Ground	<b>Ground for the device.</b>
V <sub>DDQ</sub>	I/O Power Supply	<b>Power supply for the I/O circuitry.</b>
MODE	Input-Static	<b>Selects Burst Order.</b> When tied to GND selects linear burst sequence. When tied to V <sub>DD</sub> or left floating selects interleaved burst sequence. This is a strap pin and should remain static during device operation. Mode Pin has an internal pull-up.
NC		<b>No Connects.</b> Not Internally connected to the die. 2M, 4M, 9M, 18M, 72M, 144M, 288M, 576M and 1G are address expansion pins and are not internally connected to the die.

## Functional Overview

All synchronous inputs pass through input registers controlled by the rising edge of the clock. Maximum access delay from the clock rise ( $t_{CDV}$ ) is 6.5 ns (133-MHz device).

The CY7C1297H supports secondary cache in systems utilizing either a linear or interleaved burst sequence. The interleaved burst order supports Pentium and i486™ processors. The linear burst sequence is suited for processors that utilize a linear burst sequence. The burst order is user-selectable, and is determined by sampling the MODE input. Accesses can be initiated with either the Processor Address Strobe (ADSP) or the Controller Address Strobe (ADSC). Address advancement through the burst sequence is controlled by the ADV input. A two-bit on-chip wraparound burst counter captures the first address in a burst sequence and automatically increments the address for the rest of the burst access.

Byte Write operations are qualified with the Byte Write Enable (BWE) and Byte Write Select ( $BW_{[A:D]}$ ) inputs. A Global Write Enable (GW) overrides all byte write inputs and writes data to all four bytes. All writes are simplified with on-chip synchronous self-timed write circuitry.

Three synchronous Chip Selects ( $\overline{CE}_1$ ,  $CE_2$ ,  $\overline{CE}_3$ ) and an asynchronous Output Enable ( $\overline{OE}$ ) provide for easy bank selection and output tri-state control. ADSP is ignored if  $CE_1$  is HIGH.

### Single Read Accesses

A single read access is initiated when the following conditions are satisfied at clock rise: (1)  $\overline{CE}_1$ ,  $CE_2$ , and  $CE_3$  are all asserted active, and (2) ADSP or ADSC is asserted LOW (if the access is initiated by ADSC, the write inputs must be deasserted during this first cycle). The address presented to the address inputs is latched into the address register and the burst counter/control logic and presented to the memory core. If the OE input is asserted LOW, the requested data will be available at the data outputs a maximum to  $t_{CDV}$  after clock rise. ADSP is ignored if  $CE_1$  is HIGH.

### Single Write Accesses Initiated by ADSP

This access is initiated when the following conditions are satisfied at clock rise: (1)  $CE_1$ ,  $CE_2$ ,  $CE_3$  are all asserted active, and (2) ADSP is asserted LOW. The addresses presented are loaded into the address register and the burst inputs (GW, BWE, and  $BW_{[A:B]}$ ) are ignored during this first clock cycle. If the Write inputs are asserted active (see Write Cycle Descriptions table for appropriate states that indicate a Write) on the next clock rise, the appropriate data will be latched and written into the device. Byte Writes are allowed. During byte writes,  $BW_A$  controls  $DQ_A$  and  $BW_B$  controls  $DQ_B$ . All I/Os are tri-stated during a Byte Write. Since this is a common I/O device, the asynchronous OE input signal must be deasserted and the I/Os must be tri-stated prior to the presentation of data to DQs. As a safety precaution, the data lines are tri-stated once a Write cycle is detected, regardless of the state of OE.

### Single Write Accesses Initiated by ADSC

This write access is initiated when the following conditions are satisfied at clock rise: (1)  $\overline{CE}_1$ ,  $CE_2$ , and  $\overline{CE}_3$  are all asserted

active, (2)  $\overline{ADSC}$  is asserted LOW, (3)  $\overline{ADSP}$  is deasserted HIGH, and (4) the Write input signals (GW, BWE, and  $BW_{[A:B]}$ ) indicate a write access. ADSC is ignored if ADSP is active LOW.

The addresses presented are loaded into the address register and the burst counter/control logic and delivered to the memory core. The information presented to  $DQ_{[A:B]}$  will be written into the specified address location. Byte Writes are allowed. During Byte Writes,  $BW_A$  controls  $DQ_A$  and  $BW_B$  controls  $DQ_B$ . All I/Os are tri-stated when a write is detected, even a Byte Write. Since this is a common I/O device, the asynchronous OE input signal must be deasserted and the I/Os must be tri-stated prior to the presentation of data to DQs. As a safety precaution, the data lines are tri-stated once a Write cycle is detected, regardless of the state of OE.

### Burst Sequences

The CY7C1297H provides an on-chip two-bit wraparound burst counter inside the SRAM. The burst counter is fed by  $A_{[1:0]}$ , and can follow either a linear or interleaved burst order. The burst order is determined by the state of the MODE input. A LOW on MODE will select a linear burst sequence. A HIGH on MODE will select an interleaved burst order. Leaving MODE unconnected will cause the device to default to a interleaved burst sequence.

### Sleep Mode

The ZZ input pin is an asynchronous input. Asserting ZZ places the SRAM in a power conservation "sleep" mode. Two clock cycles are required to enter into or exit from this "sleep" mode. While in this mode, data integrity is guaranteed. Accesses pending when entering the "sleep" mode are not considered valid nor is the completion of the operation guaranteed. The device must be deselected prior to entering the "sleep" mode.  $CEs$ , ADSP, and ADSC must remain inactive for the duration of  $t_{ZZREC}$  after the ZZ input returns LOW.

### Interleaved Burst Address Table (MODE = Floating or $V_{DD}$ )

First Address A1, A0	Second Address A1, A0	Third Address A1, A0	Fourth Address A1, A0
00	01	10	11
01	00	11	10
10	11	00	01
11	10	01	00

### Linear Burst Address Table (MODE = GND)

First Address A1, A0	Second Address A1, A0	Third Address A1, A0	Fourth Address A1, A0
00	01	10	11
01	10	11	00
10	11	00	01
11	00	01	10

**ZZ Mode Electrical Characteristics**

Parameter	Description	Test Conditions	Min.	Max.	Unit
$I_{DDZZ}$	Sleep mode standby current	$ZZ \geq V_{DD} - 0.2V$		40	mA
$t_{ZZS}$	Device operation to ZZ	$ZZ \geq V_{DD} - 0.2V$		$2t_{CYC}$	ns
$t_{ZZREC}$	ZZ recovery time	$ZZ \leq 0.2V$	$2t_{CYC}$		ns
$t_{ZZI}$	ZZ Active to sleep current	This parameter is sampled		$2t_{CYC}$	ns
$t_{RZZI}$	ZZ Inactive to exit sleep current	This parameter is sampled	0		ns

**Truth Table**<sup>[2, 3, 4, 5, 6]</sup>

Cycle Description	Address Used	$\overline{CE}_1$	$\overline{CE}_2$	$\overline{CE}_3$	ZZ	ADSP	ADSC	ADV	WRITE	OE	CLK	DQ
Deselected Cycle, Power-down	None	H	X	X	L	X	L	X	X	X	L-H	Tri-State
Deselected Cycle, Power-down	None	L	L	X	L	L	X	X	X	X	L-H	Tri-State
Deselected Cycle, Power-down	None	L	X	H	L	L	X	X	X	X	L-H	Tri-State
Deselected Cycle, Power-down	None	L	L	X	L	H	L	X	X	X	L-H	Tri-State
Deselected Cycle, Power-down	None	X	X	X	L	H	L	X	X	X	L-H	Tri-State
Sleep Mode, Power-down	None	X	X	X	H	X	X	X	X	X	X	Tri-State
Read Cycle, Begin Burst	External	L	H	L	L	L	X	X	X	L	L-H	Q
Read Cycle, Begin Burst	External	L	H	L	L	L	X	X	X	H	L-H	Tri-State
Write Cycle, Begin Burst	External	L	H	L	L	H	L	X	L	X	L-H	D
Read Cycle, Begin Burst	External	L	H	L	L	H	L	X	H	L	L-H	Q
Read Cycle, Begin Burst	External	L	H	L	L	H	L	X	H	H	L-H	Tri-State
Read Cycle, Continue Burst	Next	X	X	X	L	H	H	L	H	L	L-H	Q
Read Cycle, Continue Burst	Next	X	X	X	L	H	H	L	H	H	L-H	Tri-State
Read Cycle, Continue Burst	Next	H	X	X	L	X	H	L	H	L	L-H	Q
Read Cycle, Continue Burst	Next	H	X	X	L	X	H	L	H	H	L-H	Tri-State
Write Cycle, Continue Burst	Next	X	X	X	L	H	H	L	L	X	L-H	D
Write Cycle, Continue Burst	Next	H	X	X	L	X	H	L	L	X	L-H	D
Read Cycle, Suspend Burst	Current	X	X	X	L	H	H	H	H	L	L-H	Q
Read Cycle, Suspend Burst	Current	X	X	X	L	H	H	H	H	H	L-H	Tri-State
Read Cycle, Suspend Burst	Current	H	X	X	L	X	H	H	H	L	L-H	Q
Read Cycle, Suspend Burst	Current	H	X	X	L	X	H	H	H	H	L-H	Tri-State
Write Cycle, Suspend Burst	Current	X	X	X	L	H	H	H	L	X	L-H	D
Write Cycle, Suspend Burst	Current	H	X	X	L	X	H	H	L	X	L-H	D

**Notes:**

- X = "Don't Care." H = Logic HIGH, L = Logic LOW.
- $\overline{WRITE} = L$  when any one or more Byte Write Enable signals ( $\overline{BW}_A, \overline{BW}_B$ ) and  $\overline{BWE} = L$  or  $\overline{GW} = L$ .  $\overline{WRITE} = H$  when all Byte Write Enable signals ( $\overline{BW}_A, \overline{BW}_B$ ),  $\overline{BWE}$ ,  $\overline{GW} = H$ .
- The DQ pins are controlled by the current cycle and the  $\overline{OE}$  signal.  $\overline{OE}$  is asynchronous and is not sampled with the clock.
- The SRAM always initiates a Read cycle when ADSP is asserted, regardless of the state of  $\overline{GW}$ ,  $\overline{BWE}$ , or  $\overline{BW}_{[A, B]}$ . Writes may occur only on subsequent clocks after the ADSP or with the assertion of ADSC. As a result,  $\overline{OE}$  must be driven HIGH prior to the start of the Write cycle to allow the outputs to tri-state.  $\overline{OE}$  is a don't care for the remainder of the Write cycle.
- $\overline{OE}$  is asynchronous and is not sampled with the clock rise. It is masked internally during Write cycles. During a Read cycle all data bits are tri-state when  $\overline{OE}$  is inactive or when the device is deselected, and all data bits behave as output when  $\overline{OE}$  is active (LOW).

**Truth Table for Read/Write<sup>[2, 3]</sup>**

Function	$\overline{GW}$	$\overline{BWE}$	$\overline{BW}_B$	$\overline{BW}_A$
Read	H	H	X	X
Read	H	L	H	H
Write Byte (A, $DQP_A$ )	H	L	H	L
Write Byte (B, $DQP_B$ )	H	L	L	H
Write All Bytes	H	L	L	L
Write All Bytes	L	X	X	X

**Maximum Ratings**

(Above which the useful life may be impaired. For user guidelines, not tested.)

Storage Temperature ..... -65°C to + 150°C  
 Ambient Temperature with Power Applied..... -55°C to + 125°C  
 Supply Voltage on V<sub>DD</sub> Relative to GND..... -0.5V to + 4.6V  
 Supply Voltage on V<sub>DDQ</sub> Relative to GND ..... -0.5V to + V<sub>DD</sub>  
 DC Voltage Applied to Outputs in Tri-State..... -0.5V to V<sub>DDQ</sub> + 0.5V

DC Input Voltage ..... -0.5V to V<sub>DD</sub> + 0.5V  
 Current into Outputs (LOW)..... 20 mA  
 Static Discharge Voltage..... >2001V (per MIL-STD-883, Method 3015)  
 Latch-up Current..... >200 mA

**Operating Range**

Range	Ambient Temperature	V <sub>DD</sub>	V <sub>DDQ</sub>
Commercial	0°C to +70°C	3.3V -5%/+10%	2.5V -5% to V <sub>DD</sub>
Industrial	-40°C to +85°C		

**Electrical Characteristics** Over the Operating Range [7, 8]

Parameter	Description	Test Conditions	Min.	Max.	Unit
V <sub>DD</sub>	Power Supply Voltage		3.135	3.6	V
V <sub>DDQ</sub>	I/O Supply Voltage	for 3.3V I/O	3.135	V <sub>DD</sub>	V
		for 2.5V I/O	2.375	2.625	V
V <sub>OH</sub>	Output HIGH Voltage	for 3.3V I/O, I <sub>OH</sub> = -4.0 mA	2.4		V
		for 2.5V I/O, I <sub>OH</sub> = -1.0 mA	2.0		V
V <sub>OL</sub>	Output LOW Voltage	for 3.3V I/O, I <sub>OL</sub> = 8.0 mA		0.4	V
		for 2.5V I/O, I <sub>OL</sub> = 1.0 mA		0.4	V
V <sub>IH</sub>	Input HIGH Voltage <sup>[7]</sup>	for 3.3V I/O	2.0	V <sub>DD</sub> + 0.3V	V
		for 2.5V I/O	1.7	V <sub>DD</sub> + 0.3V	V
V <sub>IL</sub>	Input LOW Voltage <sup>[7]</sup>	for 3.3V I/O	-0.3	0.8	V
		for 2.5V I/O	-0.3	0.7	V
I <sub>X</sub>	Input Leakage Current except ZZ and MODE	GND ≤ V <sub>I</sub> ≤ V <sub>DDQ</sub>	-5	5	μA
	Input Current of MODE	Input = V <sub>SS</sub>	-30		μA
		Input = V <sub>DD</sub>		5	μA
	Input Current of ZZ	Input = V <sub>SS</sub>	-5		μA
Input = V <sub>DD</sub>			30	μA	
I <sub>OZ</sub>	Output Leakage Current	GND ≤ V <sub>I</sub> ≤ V <sub>DDQ</sub> , Output Disabled	-5	5	μA
I <sub>DD</sub>	V <sub>DD</sub> Operating Supply Current	V <sub>DD</sub> = Max., I <sub>OUT</sub> = 0 mA, f = f <sub>MAX</sub> = 1/t <sub>CYC</sub>	7.5-ns cycle, 133 MHz	225	mA
			10.0-ns cycle, 100 MHz	205	mA
I <sub>SB1</sub>	Automatic CE Power-Down Current—TTL Inputs	Max. V <sub>DD</sub> , Device Deselected, V <sub>IN</sub> ≥ V <sub>IH</sub> or V <sub>IN</sub> ≤ V <sub>IL</sub> , f = f <sub>MAX</sub> , inputs switching	7.5-ns cycle, 133 MHz	90	mA
			10.0-ns cycle, 100 MHz	80	mA
I <sub>SB2</sub>	Automatic CE Power-Down Current—CMOS Inputs	Max. V <sub>DD</sub> , Device Deselected, V <sub>IN</sub> ≥ V <sub>DD</sub> - 0.3V or V <sub>IN</sub> ≤ 0.3V, f = 0, inputs static	All speeds	40	mA
I <sub>SB3</sub>	Automatic CE Power-Down Current—CMOS Inputs	Max. V <sub>DD</sub> , Device Deselected, V <sub>IN</sub> ≥ V <sub>DDQ</sub> - 0.3V or V <sub>IN</sub> ≤ 0.3V, f = f <sub>MAX</sub> , inputs switching	7.5-ns cycle, 133 MHz	75	mA
			10.0-ns cycle, 100 MHz	65	mA
I <sub>SB4</sub>	Automatic CE Power-Down Current—TTL Inputs	Max. V <sub>DD</sub> , Device Deselected, V <sub>IN</sub> ≥ V <sub>DD</sub> - 0.3V or V <sub>IN</sub> ≤ 0.3V, f = 0, inputs static	All speeds	45	mA

**Notes:**

7. Overshoot: V<sub>IH</sub>(AC) < V<sub>DD</sub> + 1.5V (Pulse width less than t<sub>CYC</sub>/2), undershoot: V<sub>IL</sub>(AC) > -2V (Pulse width less than t<sub>CYC</sub>/2).
8. T<sub>Power-up</sub>: Assumes a linear ramp from 0V to V<sub>DD</sub>(min.) within 200 ms. During this time V<sub>IH</sub> < V<sub>DD</sub> and V<sub>DDQ</sub> ≤ V<sub>DD</sub>.



Capacitance<sup>[9]</sup>

Parameter	Description	Test Conditions	100 TQFP Max.	Unit
$C_{IN}$	Input Capacitance	$T_A = 25^\circ\text{C}$ , $f = 1\text{ MHz}$ , $V_{DD} = 3.3\text{V}$ , $V_{DDQ} = 2.5\text{V}$	5	pF
$C_{CLK}$	Clock Input Capacitance		5	pF
$C_{I/O}$	Input/Output Capacitance		5	pF

Thermal Resistance<sup>[9]</sup>

Parameter	Description	Test Conditions	100 TQFP Package	Unit
$\Theta_{JA}$	Thermal Resistance (Junction to Ambient)	Test conditions follow standard test methods and procedures for measuring thermal impedance, per EIA/JESD51	30.32	$^\circ\text{C/W}$
$\Theta_{JC}$	Thermal Resistance (Junction to Case)		6.85	$^\circ\text{C/W}$

AC Test Loads and Waveforms

3.3V I/O Test Load

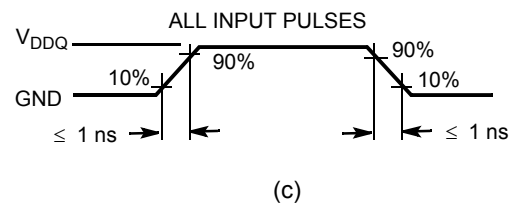
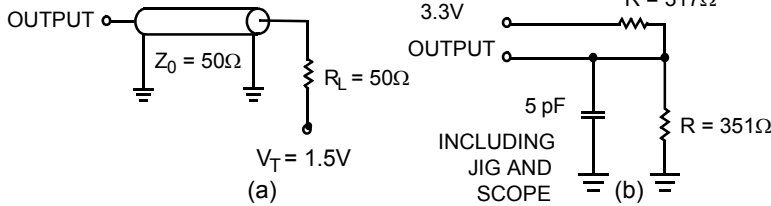

2.5V I/O Test Load

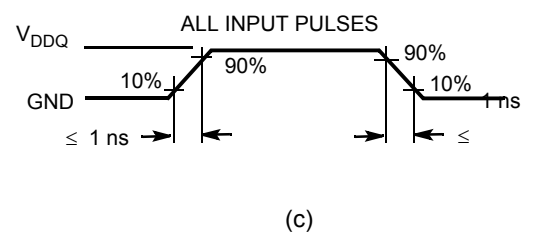
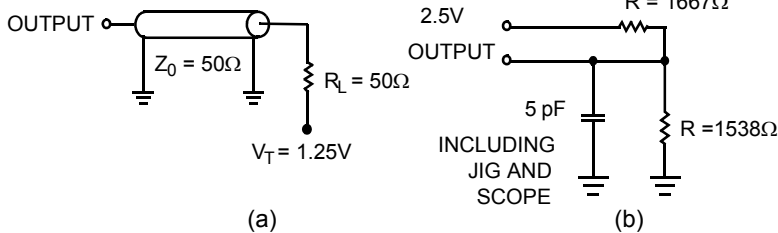

Note:

9. Tested initially and after any design or process change that may affect these parameters.



**Switching Characteristics** Over the Operating Range [10, 11]

Parameter	Description	133 MHz		100 MHz		Unit
		Min.	Max.	Min.	Max.	
$t_{POWER}$	$V_{DD}$ (Typical) to the First Access <sup>[12]</sup>	1		1		ms
<b>Clock</b>						
$t_{CYC}$	Clock Cycle Time	7.5		10.0		ns
$t_{CH}$	Clock HIGH	2.5		4.0		ns
$t_{CL}$	Clock LOW	2.5		4.0		ns
<b>Output Times</b>						
$t_{CDV}$	Data Output Valid after CLK Rise		6.5		8.0	ns
$t_{DOH}$	Data Output Hold after CLK Rise	2.0		2.0		ns
$t_{CLZ}$	Clock to Low-Z <sup>[13, 14, 15]</sup>	0		0		ns
$t_{CHZ}$	Clock to High-Z <sup>[13, 14, 15]</sup>		3.5		3.5	ns
$t_{OEVL}$	$\overline{OE}$ LOW to Output Valid		3.5		3.5	ns
$t_{OELZ}$	$\overline{OE}$ LOW to Output Low-Z <sup>[13, 14, 15]</sup>	0		0		ns
$t_{OEHZ}$	$\overline{OE}$ HIGH to Output High-Z <sup>[13, 14, 15]</sup>		3.5		3.5	ns
<b>Set-up Times</b>						
$t_{AS}$	Address Set-up before CLK Rise	1.5		2.0		ns
$t_{ADS}$	$\overline{ADSP}$ , $\overline{ADSC}$ Set-up before CLK Rise	1.5		2.0		ns
$t_{ADVS}$	$\overline{ADV}$ Set-up before CLK Rise	1.5		2.0		ns
$t_{WES}$	$\overline{GW}$ , $\overline{BWE}$ , $\overline{BW}_{[A:B]}$ Set-up before CLK Rise	1.5		2.0		ns
$t_{DS}$	Data Input Set-up before CLK Rise	1.5		2.0		ns
$t_{CES}$	Chip Enable Set-up	1.5		2.0		ns
<b>Hold Times</b>						
$t_{AH}$	Address Hold after CLK Rise	0.5		0.5		ns
$t_{ADH}$	$\overline{ADSP}$ , $\overline{ADSC}$ Hold after CLK Rise	0.5		0.5		ns
$t_{WEH}$	$\overline{GW}$ , $\overline{BWE}$ , $\overline{BW}_{[A:B]}$ Hold after CLK Rise	0.5		0.5		ns
$t_{ADVH}$	$\overline{ADV}$ Hold after CLK Rise	0.5		0.5		ns
$t_{DH}$	Data Input Hold after CLK Rise	0.5		0.5		ns
$t_{CEH}$	Chip Enable Hold after CLK Rise	0.5		0.5		ns

**Notes:**

10. Timing reference level is 1.5V when  $V_{DDQ} = 3.3V$  and is 1.25V when  $V_{DDQ} = 2.5V$ .
11. Test conditions shown in (a) of AC Test Loads unless otherwise noted.
12. This part has a voltage regulator internally;  $t_{POWER}$  is the time that the power needs to be supplied above  $V_{DD}$ (minimum) initially before a Read or Write operation can be initiated.
13.  $t_{CHZ}$ ,  $t_{CLZ}$ ,  $t_{OELZ}$ , and  $t_{OEHZ}$  are specified with AC test conditions shown in (a) of AC Test Loads. Transition is measured  $\pm 200$  mV from steady-state voltage.
14. At any given voltage and temperature,  $t_{OEHZ}$  is less than  $t_{OELZ}$  and  $t_{CHZ}$  is less than  $t_{CLZ}$  to eliminate bus contention between SRAMs when sharing the same data bus. These specifications do not imply a bus contention condition, but reflect parameters guaranteed over worst case user conditions. Device is designed to achieve High-Z prior to Low-Z under the same system conditions.
15. This parameter is sampled and not 100% tested.

**Timing Diagrams**  
**Read Cycle Timing<sup>[16]</sup>**

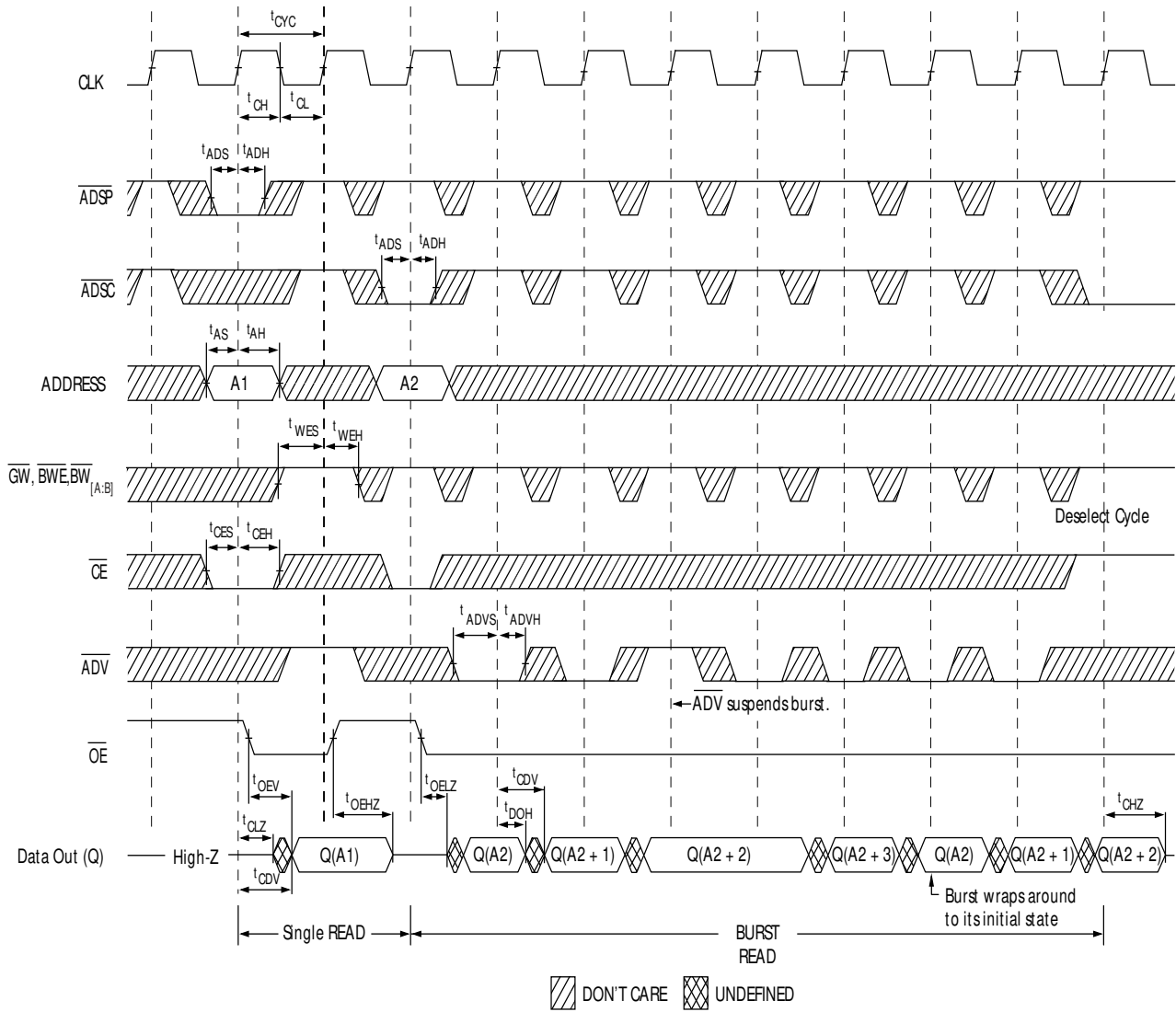

**Note:**

16. On this diagram, when  $\overline{CE}$  is LOW,  $\overline{CE}_1$  is LOW,  $CE_2$  is HIGH and  $\overline{CE}_3$  is LOW. When  $\overline{CE}$  is HIGH,  $\overline{CE}_1$  is HIGH or  $CE_2$  is LOW or  $\overline{CE}_3$  is HIGH.

**Timing Diagrams (continued)**

**Write Cycle Timing<sup>[16, 17]</sup>**

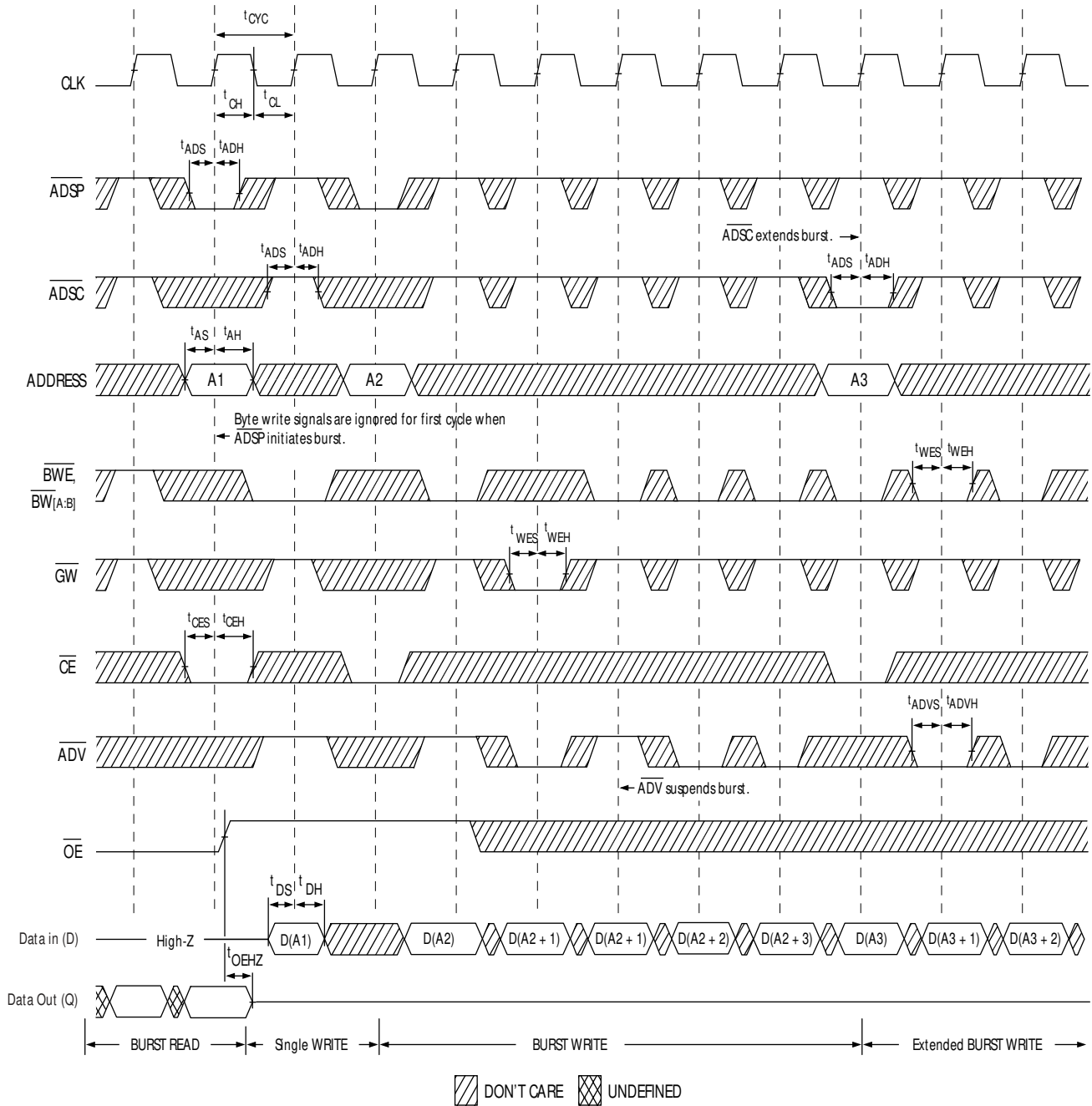

**Note:**

17. Full width Write can be initiated by either  $\overline{GW}$  LOW; or by  $\overline{GW}$  HIGH,  $\overline{BWE}$  LOW and  $\overline{BW}_{[A:B]}$  LOW.

Timing Diagrams (continued)

Read/Write Timing<sup>[16, 18, 19]</sup>

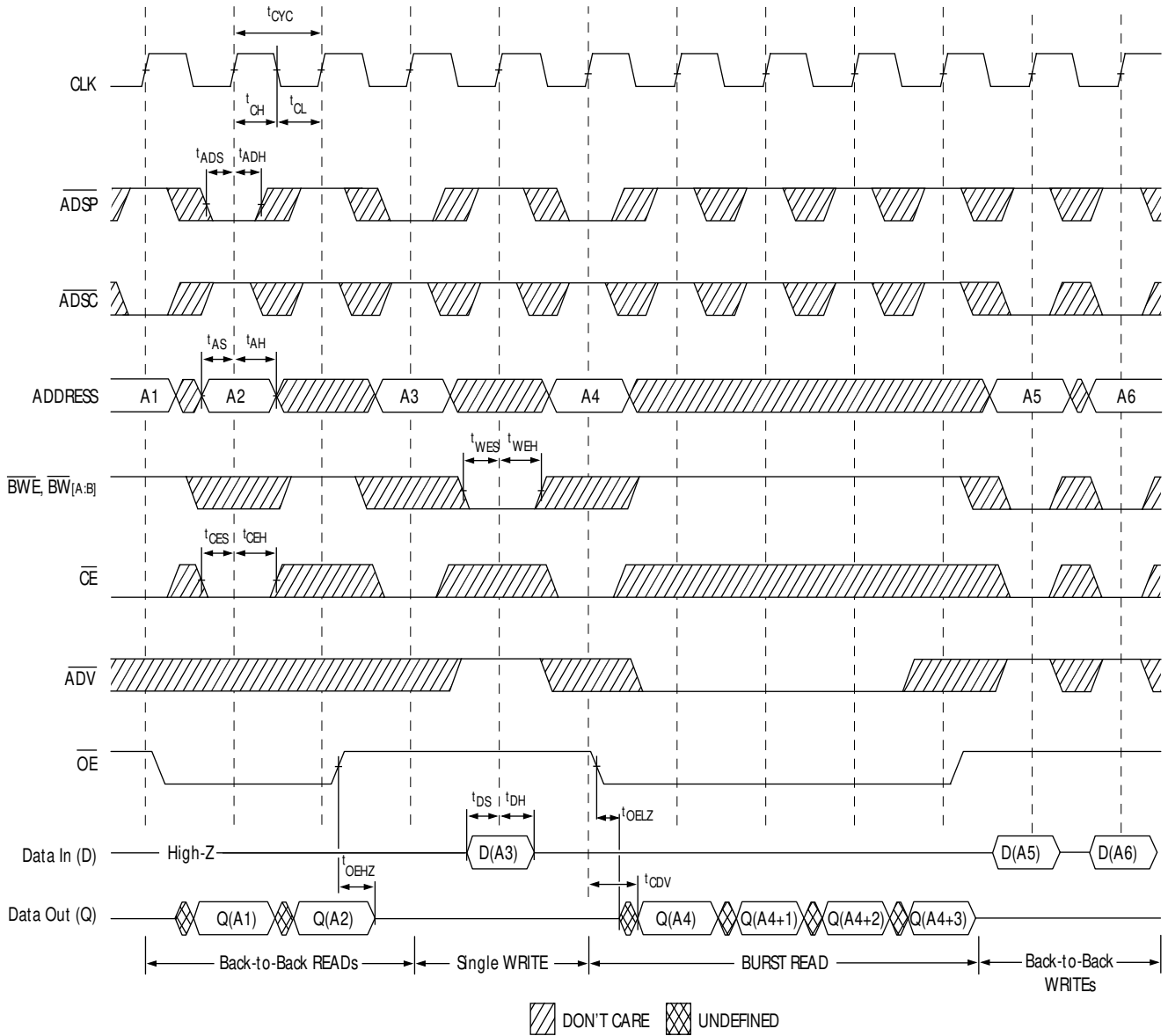

Notes:

- 18. The data bus (Q) remains in High-Z following a Write cycle unless an  $\overline{ADSP}$ ,  $\overline{ADSC}$ , or  $\overline{ADV}$  cycle is performed.
- 19.  $\overline{GW}$  is HIGH.

**Timing Diagrams** (continued)

**ZZ Mode Timing**<sup>[20, 21]</sup>

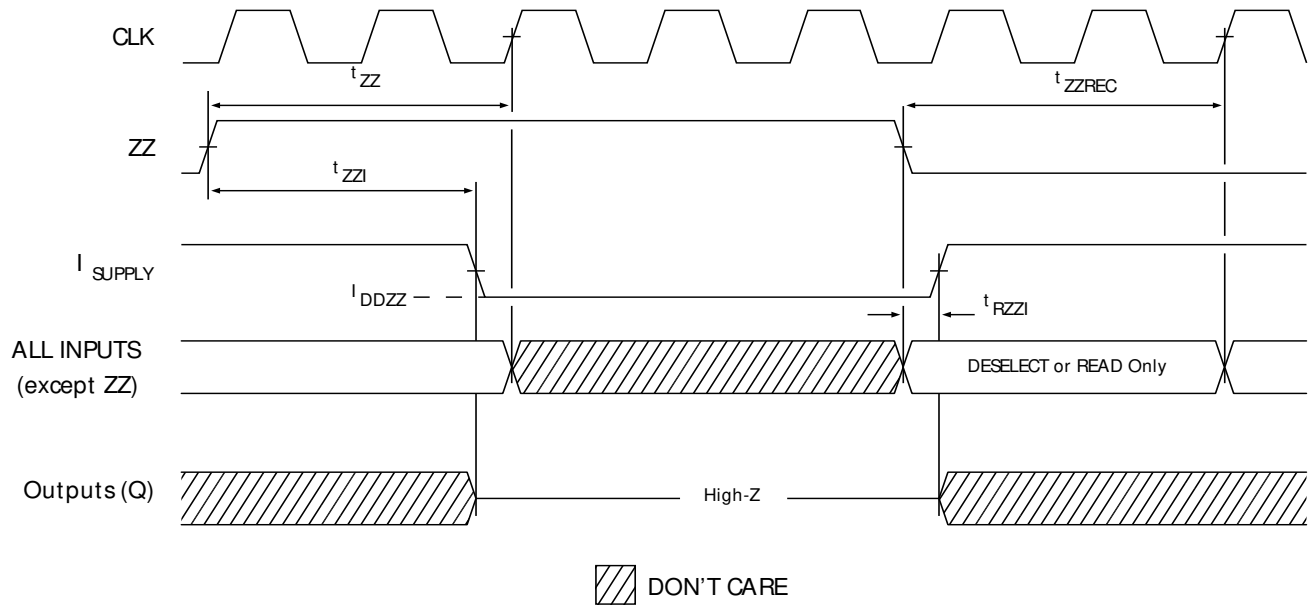

**Notes:**

- 20. Device must be deselected when entering ZZ mode. See Cycle Descriptions table for all possible signal conditions to deselect the device.
- 21. DQs are in High-Z when exiting ZZ sleep mode.

**Ordering Information**

Cypress offers other versions of this type of product in many different configurations and features. The below table contains only the list of parts that are currently available. For a complete listing of all options, visit the Cypress website at [www.cypress.com](http://www.cypress.com) and refer to the product summary page at <http://www.cypress.com/products> or contact your local sales representative. Cypress maintains a worldwide network of offices, solution centers, manufacturer's representatives and distributors. To find the office closest to you, visit us at <http://www.cypress.com/go/datasheet/offices>.

Speed (MHz)	Ordering Code	Package Diagram	Package Type	Operating Range
133	CY7C1297H-133AXC	51-85050	100-pin Thin Quad Flat Pack (14 x 20 x 1.4 mm) Lead-Free	Commercial

**Package Diagram**

100 Lead Thin Plastic Quad Flatpack 14 X 20 X 1.4mm

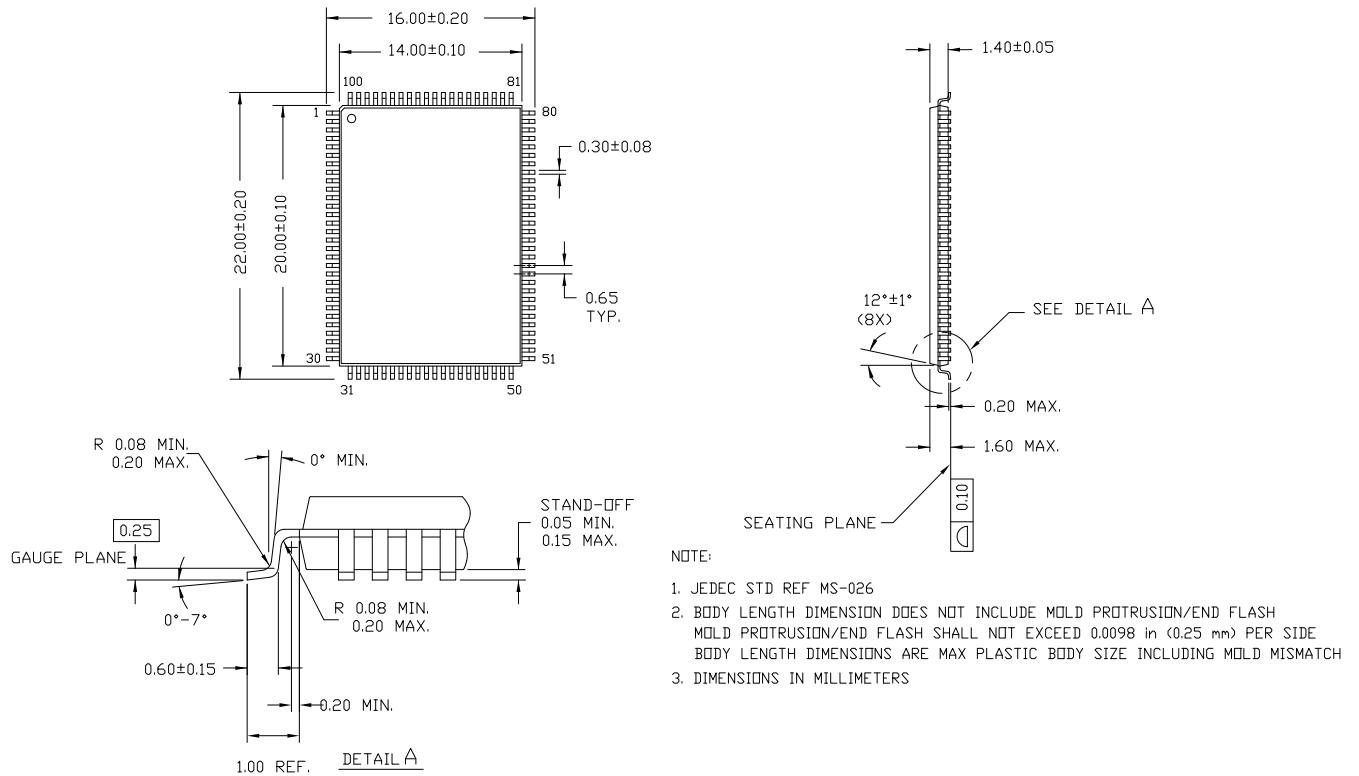

51-85050 \*C

**Document History**

<b>Document Title: CY7C1297H 1-Mbit (64K x 18) Flow-Through Sync SRAM</b>				
<b>Document Number: 38-05669</b>				
<b>REV.</b>	<b>ECN NO.</b>	<b>Issue Date</b>	<b>Orig. of Change</b>	<b>Description of Change</b>
**	345879	See ECN	PCI	New Data Sheet
*A	430677	See ECN	NXR	Changed address of Cypress Semiconductor Corporation on Page# 1 from "3901 North First Street" to "198 Champion Court" Added 2.5V I/O option Changed Three-State to Tri-State Included Maximum Ratings for $V_{DDQ}$ relative to GND Modified "Input Load" to "Input Leakage Current except ZZ and MODE" in the Electrical Characteristics Table Modified test condition from $V_{IH} \leq V_{DD}$ to $V_{IH} < V_{DD}$ Replaced Package Name column with Package Diagram in the Ordering Information table
*B	482139	See ECN	VKN	Converted from Preliminary to Final. Updated the Ordering Information table.
*C	2896202	03/19/2010	NJY	Removed Inactive parts from the Ordering Information table; Updated package diagram.