

PRODUCT NO.
77031-102

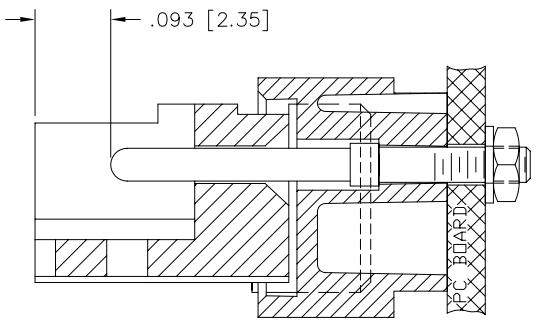
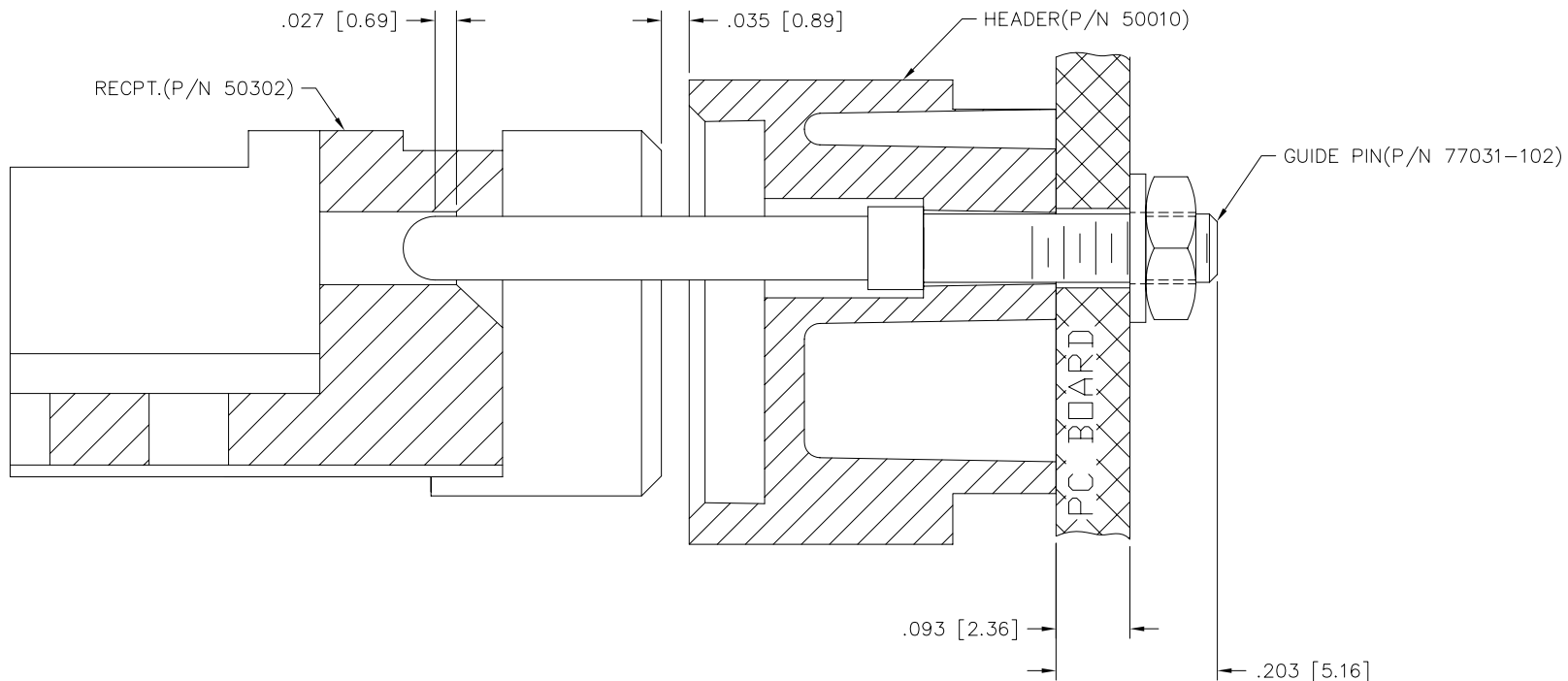

HOUSINGS FULLY MATED
(SCALE 20:1)

mat'l. code		surface		tolerance		projection		product family	
SEE TABLE		ISO 1302 ✓		ISO 406		ISO 1101		HPC	
ltr	ecn	no	dr	date	tolerances unless otherwise specified		title		
H					angles	linear	INCH/MM		CENTER GUIDE PIN
					0°±2'	.XX±.01/.3	scale 1:1		
						.XXX±.005/.13	FCJ		dwg no
						.XXX±.0020/.051			sheet 2 of 5
					dr	LSANDERS	3/22/00		size
					enr	M.GRAY	3/22/00		A3
					chr	M.GRAY	3/22/00		
					appd	M.GRAY	3/22/00		
sheet	revision							type Product Customer Drawing	
index	sheet								

FCJ
 FCJconnect.com
 Copyright FCJ

PRODUCT NO
77031-103

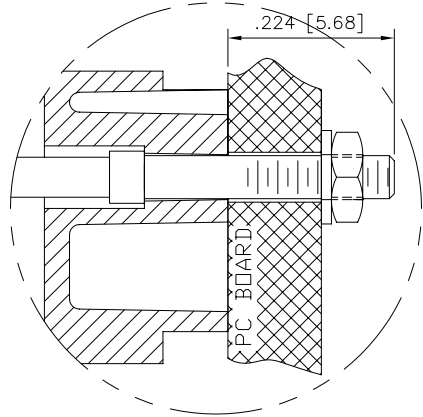
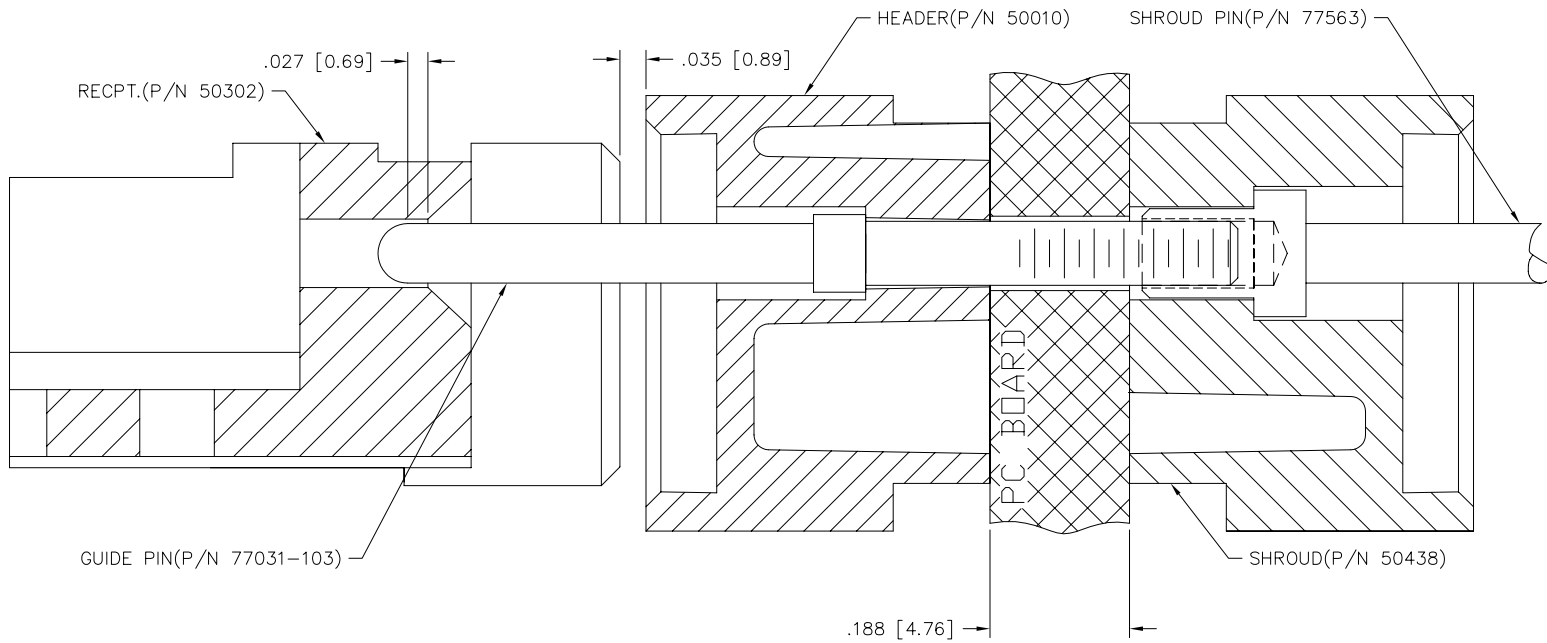

BOARD MOUNTED OPTION
(SCALE 30:1)

mat'l. code SEE TABLE		surface ISO 1302 ✓	tolerance ISO 406 ISO 1101	projection ⊕	product family HPC
ltr	ecr	no	dr	date	tolerances unless otherwise specified
H					angles linear 0°±2'
					.xx±.01/.3 .xxx±.005/.13 .xxxx±.0020/.05
					dr LSANDERS 3/22/00 enr M.GRAY 3/22/00 chr M.GRAY 3/22/00 appd M.GRAY 3/22/00
sheet	revision				scale 1:1
index	sheet				INCH/MM
					FCJ
					title CENTER GUIDE PIN
					dwg no 77031 sheet 3 of 5 size A3
					type Product Customer Drawing

FCJ
FCJconnect.com
Copyright FCJ

PRODUCT NO
77031-106

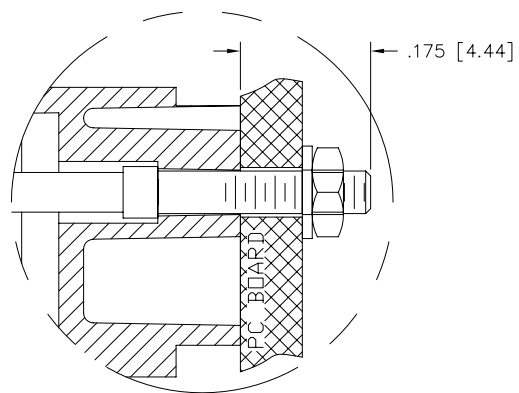
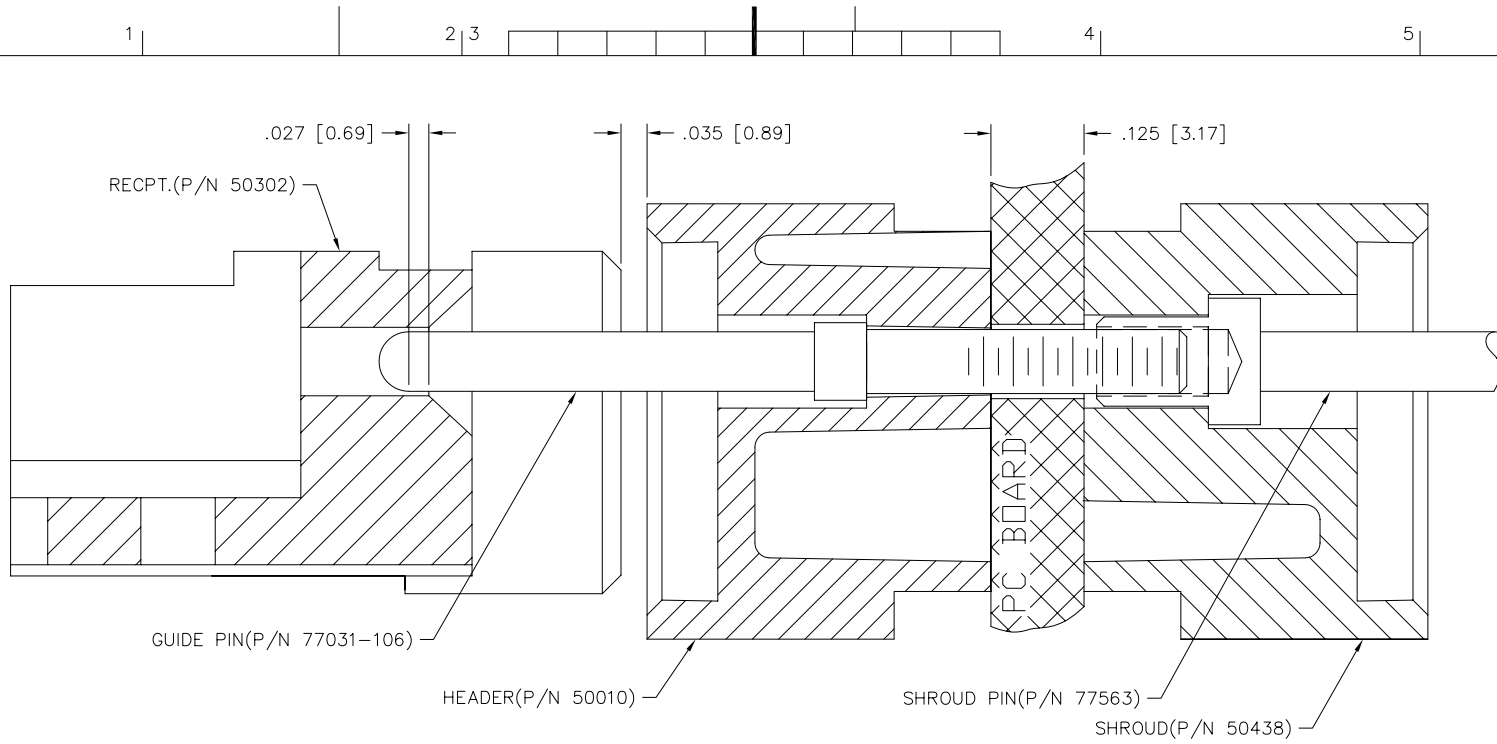

SCREW MOUNTED OPTION
(SCALE 30:1)

mat'l. code SEE TABLE		surface ISO 1302 ✓	tolerance ISO 406 ISO 1101	projection FIRST ANGLE	product family HPC
ltr	ecn no	dr	date	tolerances unless otherwise specified	title
H				angles linear .XX±.01/.3 .xxx±.005/.13 .xxxx±.0020/.051	INCH/MM
				0°±2'	scale 1:1
		dr	LSANDERS	3/22/00	
		enr	M.GRAY	3/22/00	
		chr	M.GRAY	3/22/00	
		appd	M.GRAY	3/22/00	
sheet index	revision sheet				dwg no 77031 sheet 4 of 5 size A3 type Product Customer Drawing

Copyright FCI
 FCIconnect.com

PRODUCT NO
77031-113

GUIDE PIN(P/N 77031-113)

HEADER(P/N 50010)

.027 [0.69]

.035 [0.89]

.583 [14.81]
MAX. STACK

RECPT.(P/N 50302)

PC BOARD

MOUNTING
FRAME



Copyright FCI

mat'l. code SEE TABLE		surface ISO 1302 ✓	tolerance ISO 406 ISO 1101	projection ⊕	product family HPC	
ltr	ecn no	dr	date	tolerances unless otherwise specified	title	
H				angles linear 0°±2'	CENTER GUIDE PIN	
				.XX±.01/.3 .XXX±.005/.13 .XXXX±.0020/.051	INCH/MM	
				dr	scale 1:1	
				LSANDERS 3/22/00		
				enr M.GRAY 3/22/00		dwg no 77031 sheet 5 of 5 size A3
				chr M.GRAY 3/22/00		
				appd M.GRAY 3/22/00		type Product Customer Drawing
sheet index	revision sheet					

form: A3