

Silicon Power Rectifier S/R36 Series

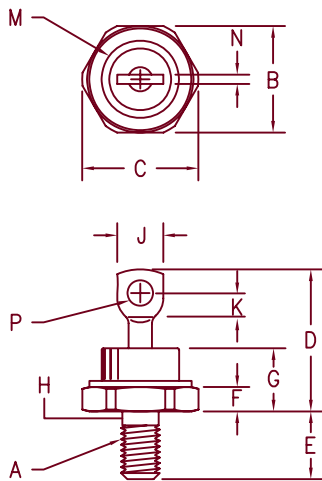

- Notes:
- 1/4-28
 - Full threads within 2 1/2 threads
 - Standard polarity:
Stud is cathode
Reverse polarity:
Stud is anode

Dim.	Inches		Millimeter		Notes
	Minimum	Maximum	Minimum	Maximum	
A	---	---	---	---	1
B	.667	.687	16.95	17.44	
C	---	.793	---	20.14	
D	---	1.00	---	25.40	
E	.422	.453	10.72	11.50	
F	.115	.200	2.93	5.08	
G	---	.450	---	11.43	
H	.220	.249	5.59	6.32	2
J	.250	.375	6.35	9.52	
K	.156	---	3.97	---	
M	---	.667	---	16.94	Dia
N	---	.080	---	2.03	
P	.140	.175	3.56	4.44	Dia

D0203AB (D05)

Microsemi Catalog Number		Peak Reverse Voltage
Standard	Reverse	
S3610	R3610	100V
S3620	R3620	200V
S3640	R3640	400V
S3660	R3660	600V
S3680	R3680	800V
S36100	R36100	1000V
S36120	R36120	1200V
S36140	R36140	1400V
S36160	R36160	1600V

- Low thermal resistance
- Glass Passivated Die
- 1200 Amps Surge Rating
- Glass to metal seal construction
- VRRM to 1600V

Electrical Characteristics

Average forward current	IF(AV) 70 Amps	TC = 151°C, Half Sine Wave, RθJC = 0.65°C/W
Maximum surge current	IFSM 1200 Amps	8.3ms, half sine, TJ = 200°C
Max I ² t for fusing	I ² t 6000 A ² s	
Max peak forward voltage	VFM 1.25 Volts	IFM = 200A: TJ = 25°C*
Max peak reverse current	IRM 25 μA	VRRM, TJ = 25°C
Max peak reverse current	IRM 2.0 mA	VRRM, TJ = 150°C*
Max Recommended Operating Frequency	10kHz	

*Pulse test: Pulse width 300 μsec. Duty cycle 2%

Thermal and Mechanical Characteristics

Storage temperature range	TSTG	-65°C to 200°C
Operating junction temp range	TJ	-65°C to 200°C
Maximum thermal resistance	RθJC	0.65°C/W Junction to Case
Mounting torque		25-30 inch pounds
Weight		.6 ounces (17 grams) typical



6 Lake Street
Lawrence, MA 01841
PH: (978) 620-2600
FAX: (978) 689-0803
www.microsemi.com

05-02-07 Rev. 2

S/R36

Figure 1
Typical Forward Characteristics

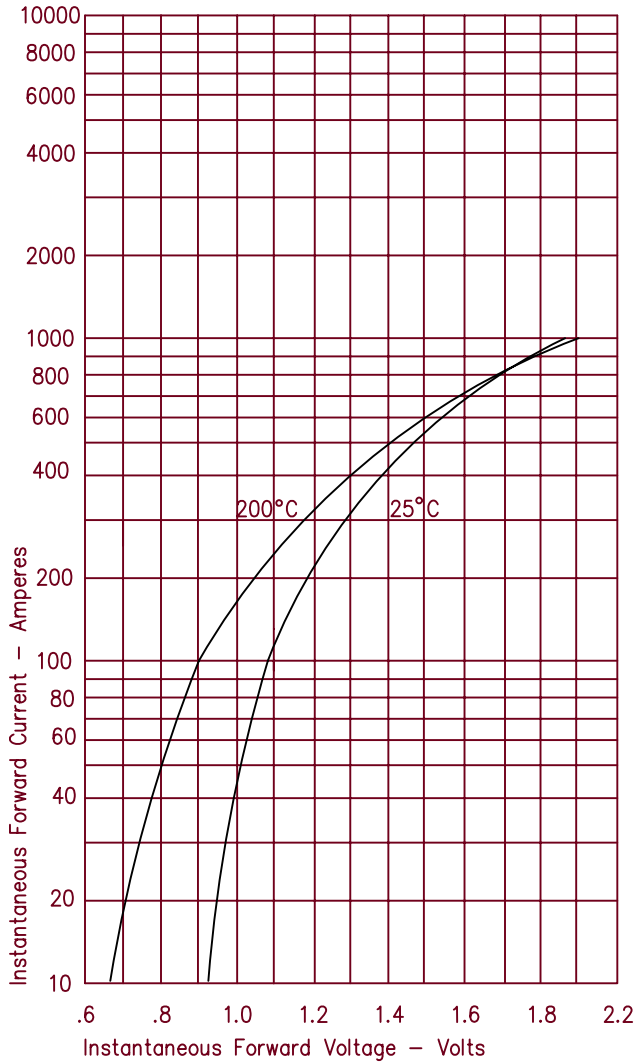

Figure 3
Forward Current Derating

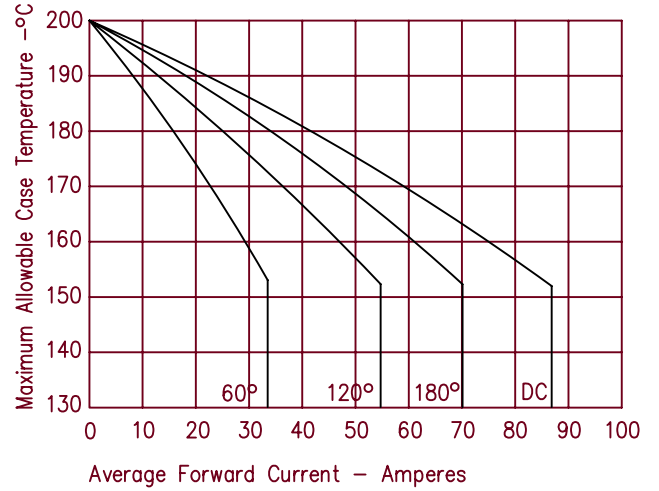

Figure 4
Maximum Forward Power Dissipation

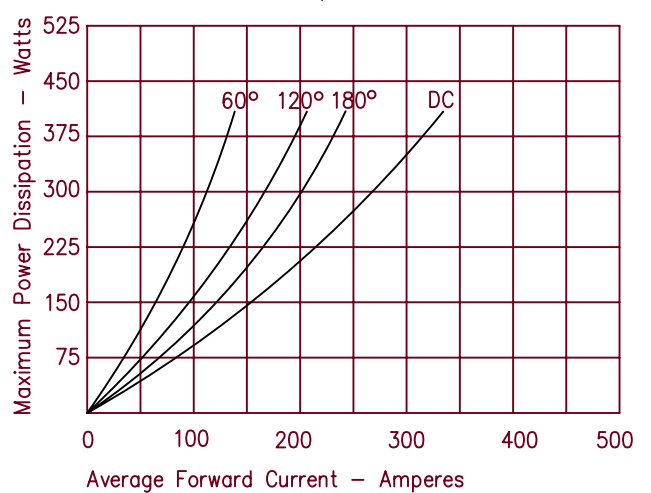

Figure 2
Typical Reverse Characteristics

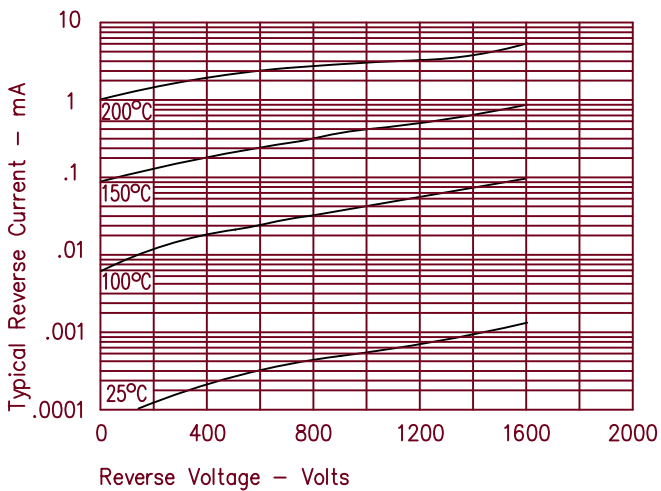

Figure 5
Transient Thermal Impedance

