

240 Watts

AC-DC Medical Switching
Power Supply

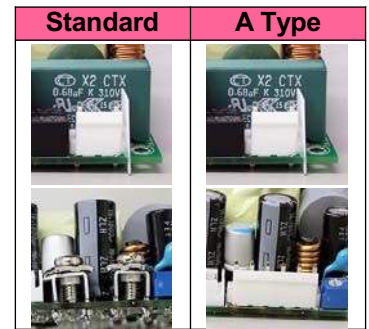

Please refer to the types of terminal block; the pictures shown are for illustration purpose only, actual product may vary.

KEY FEATURES

- Enclosed Medical Switching Power Supply n 4000VAC Input to Output 2MOPP Insulation n High Efficiency up to 93%
- With P.F.C. Function >0.9
- <0.5W No Load Input Power
- EMI for Both Class I (with PE) and Class II (without PE) Configuration
- Suitable for BF Application with Appropriate System Consideration
- UL / IEC / EN 60601 3.1 Edition & UL / IEC / EN 60950 AM2 Safety Approvals



ELECTRICAL SPECIFICATIONS

All specifications valid at normal input voltage, full load and +25°C after warm-up time unless otherwise stated.

Model No.	HDM240E-112	HDM240E-115	HDM240E-124	HDM240E-148	
Max Output Wattage (with 10CFM FAN) (W)	240 W				
Input	Voltage (Note 4)	90-264 VAC			
	Frequency (Hz)	47-63 Hz			
	Current (Full load)	< 3.0 A max. (115 VAC) / < 1.5 A max. (230 VAC)			
	Inrush Current (<2ms)	< 45 A max. (115 VAC) / < 90 A max. (230 VAC)			
	Leakage Current	< 0.1mA / 264 VAC (Touch Current)			
	Power Factor	PF>0.9 at Full Load			
Output	Voltage (V.DC.)	12V	15 V	24V	48V
	Voltage Adj Range (V.DC.)	±4% Output Voltage			
	Voltage Accuracy	±2%			
	Current (A) (max.)	20	16	10	5
	Line Regulation	±1%			
	Load Regulation (0-100%)	±1%			
	Minimum Load	0%			
	Maximum Capacitive Load	8000µF	2000µF	3000µF	470µF
	Ripple & Noise (max.) (Note 1)	1% Vout			
	Efficiency (at 230VAC) (Note 6)	92%	92%	92.5%	93%
Hold-up Time (at 115 VAC) (Note 2)	10 ms min.				
Protection	Over Power Protection	Auto recovery, Hiccup mode			
	Over Voltage Protection	Auto recovery			
	Over Temperature Protection	Auto recovery			
	Short Circuit Protection	Protection level 1 (nominal) : Continuous, Auto recovery Protection level 2 (instantaneous high current) : Latch			
Isolation	Input-Output (Note 5)	4000VAC or 5656VDC			
	Input-PE (Note 5)	2000VAC or 2828VDC			
	Output-PE (Note 5)	1500VAC or 2121VDC			
Environment	Operating Temperature	-30°C...+70°C (with derating)			
	Storage Temperature	-30°C...+85°C			
	Temperature Coefficient	±0.05%/°C			
	Altitude During Operation	5000m			
	Humidity	20~90% RH			
	Atmospheric Pressure	56 kPa to 106 kPa			
	MTBF	>250,000 h @ 25°C (MIL-HDBK-217F, Notice 1)			
	Vibration	IEC60068-2-6 (10~500Hz, 2G 10min./1cycle, 60min. each along X, Y, Z axes)			
Shock	IEC60068-2-27				

ELECTRICAL SPECIFICATIONS

All specifications valid at normal input voltage, full load and +25°C after warm-up time unless otherwise stated.

Model No.		HDM240E-112	HDM240E-115	HDM240E-124	HDM240E-148
Physical	Dimensions (L x W x H)	4.1 x 2.44 x 1.99 Inches (104.0 x 62.0 x 50.5 mm) Tolerance ±0.5 mm			
	Weight	328 g			
Safety	Approval	112/124/148: UL / IEC / EN 60601 3.1 st Edition (2 x MOPP) , UL / IEC / EN 60950 AM2, UL / IEC / EN 62368			
	Approval / Meet	115: UL / IEC / EN 60601 3.1 st Edition (2 x MOPP) , UL / IEC / EN 60950 AM2 (meet), UL / IEC / EN 62368 (meet)			
EMC	Conducted EMI (Note 7)	EN55011 Conducted Class B			
	Radiated EMI (Note 7)	EN55011 Class I class B / Class II class A			
	EMS	EN60601-1-2 4th edition			

NOTE

1. Ripple & Noise are measured at 20MHz of bandwidth with 0.1uF & 47uF parallel capacitor.
2. Hold-up Time measured at 90% Vout.
3. Main Vout must be >50% Load, 12V (Aux) / 0.5A.
4. Please check the derating curve for more details.
5. Strongly recommend to conduct this test with DC Voltage. If customer wishes to test with AC Voltage, please disconnect all Y-Capacitors from Digital Power Corporation power supply.
6. After 30 minutes of burn-in
7. Please secure the power supply unit to your metal case by using the four screw holes in the corners for either Class I or Class II equipment
8. **CAUTION: Double pole, neutral fusing. Disconnect mains before servicing.**
(ATTENTION : 2 poles avec fusible sur le neutre. Deconnecter le secteur avant intervention.)

DERATING

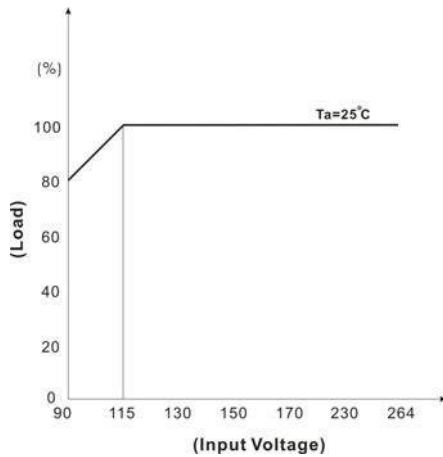
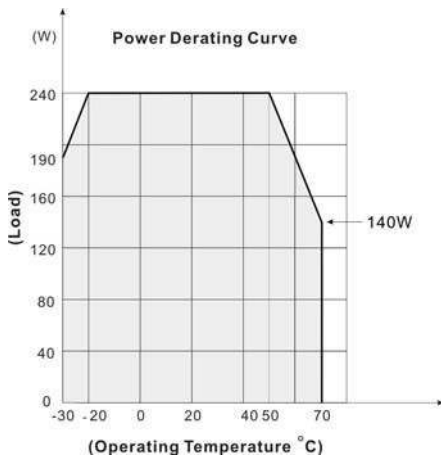

BLOCK DIAGRAM

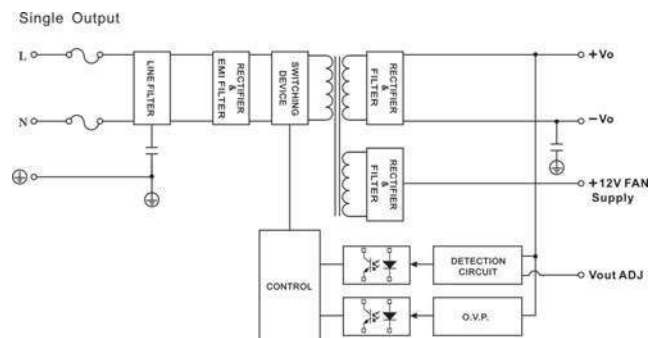

MECHANICAL DIMENSIONS (Top View)

Standard

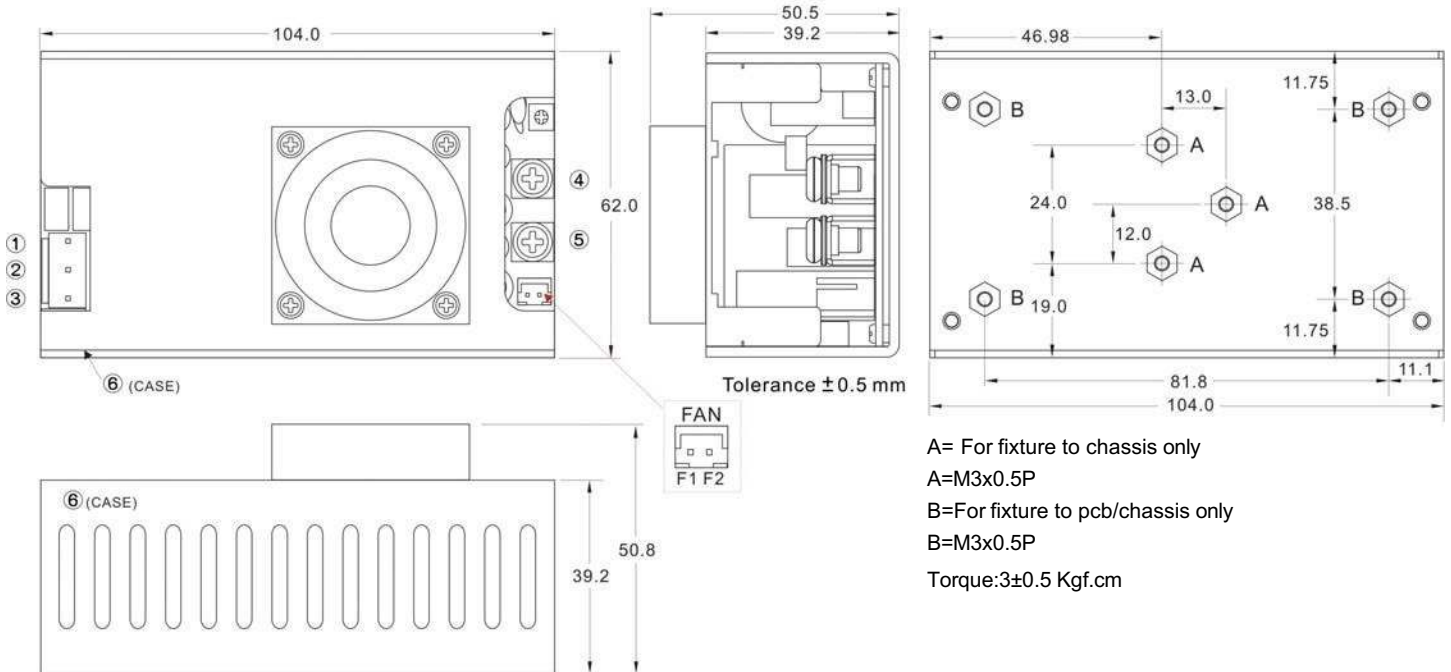

Brands		Alex		JST	
PIN#	Single	Mating Housing	Terminal	Mating Housing	Terminal
1	AC IN (N)	9396-3	96T series	VHR-3N	SVH-41T-P1.1
2	NO PIN				
3	AC IN (L)				
4	+DC OUT	Terminal : M3.5 Pan HD screw in 2 positions Torque to 8 lbs-in(90 cNm) max.			
5	-DC OUT				
6	PE	—	—	—	—

ASSEMBLY INSTRUCTIONS

*U Case T=1.5mm
Customer is advised to screw into the threads no more than 1.5mm

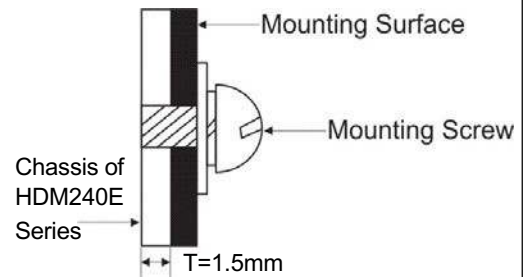

Connector Pin (FAN)					
Brands		Cheng Weei		JST	
PIN#	Single	Mating Housing	Terminal	Mating Housing	Terminal
F1	+AUX OUT	CX-H250-02	CX-T2501	XHP-2	SXH-002T-P0.6
F2	-AUX OUT				

Standard



Please refer to the types of terminal block; the pictures shown are for illustration purpose only, actual product may vary.

MECHANICAL DIMENSIONS (Top View)

A Type

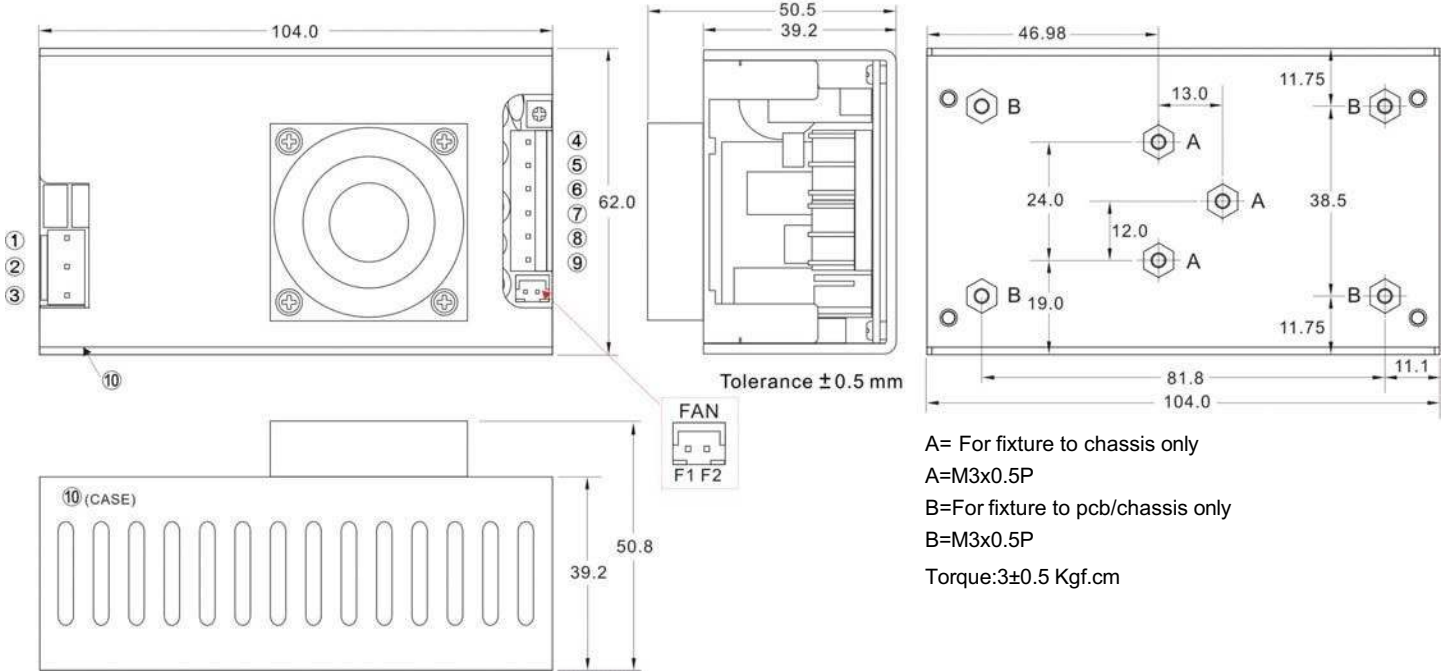

Brands		Alex		JST	
PIN#	Single	Mating Housing	Terminal	Mating Housing	Terminal
1	AC IN (N)	9396-3	96T series	VHR-3N	SVH-41T-P1.1
2	NO PIN				
3	AC IN (L)				
4~6	+DC OUT	9396-6	96T series	VHR-6N	SVH-41T-P1.1
7~9	-DC OUT				
10	PE	—	—	—	—

ASSEMBLY INSTRUCTIONS

*U Case T=1.5mm
Customer is advised to screw into the threads no more than 1.5mm

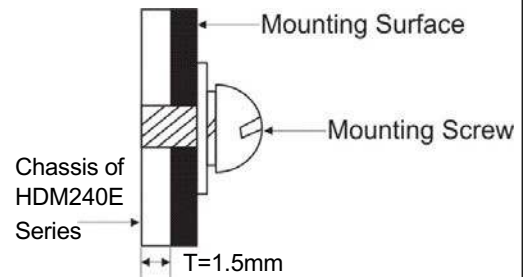

Connector Pin (FAN)					
Brands		Cheng Weei		JST	
PIN#	Single	Mating Housing	Terminal	Mating Housing	Terminal
F1	+AUX OUT	CX-H250-02	CX-T2501	XHP-2	SXH-002T-P0.6
F2	-AUX OUT				

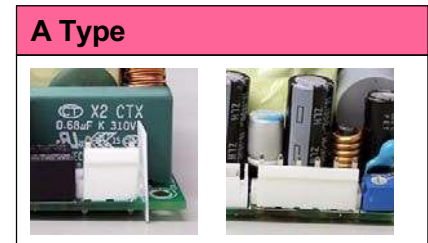

Please refer to the types of terminal block; the pictures shown are for illustration purpose only, actual product may vary.