

THIS DRAWING IS UNPUBLISHED. RELEASED FOR PUBLICATION
 © COPYRIGHT - By - ALL RIGHTS RESERVED.

REVISIONS				
P	LTR	DESCRIPTION	DATE	APVD
AB		REVISED PER ECR-18-009787	24JUL2018	BDA MD

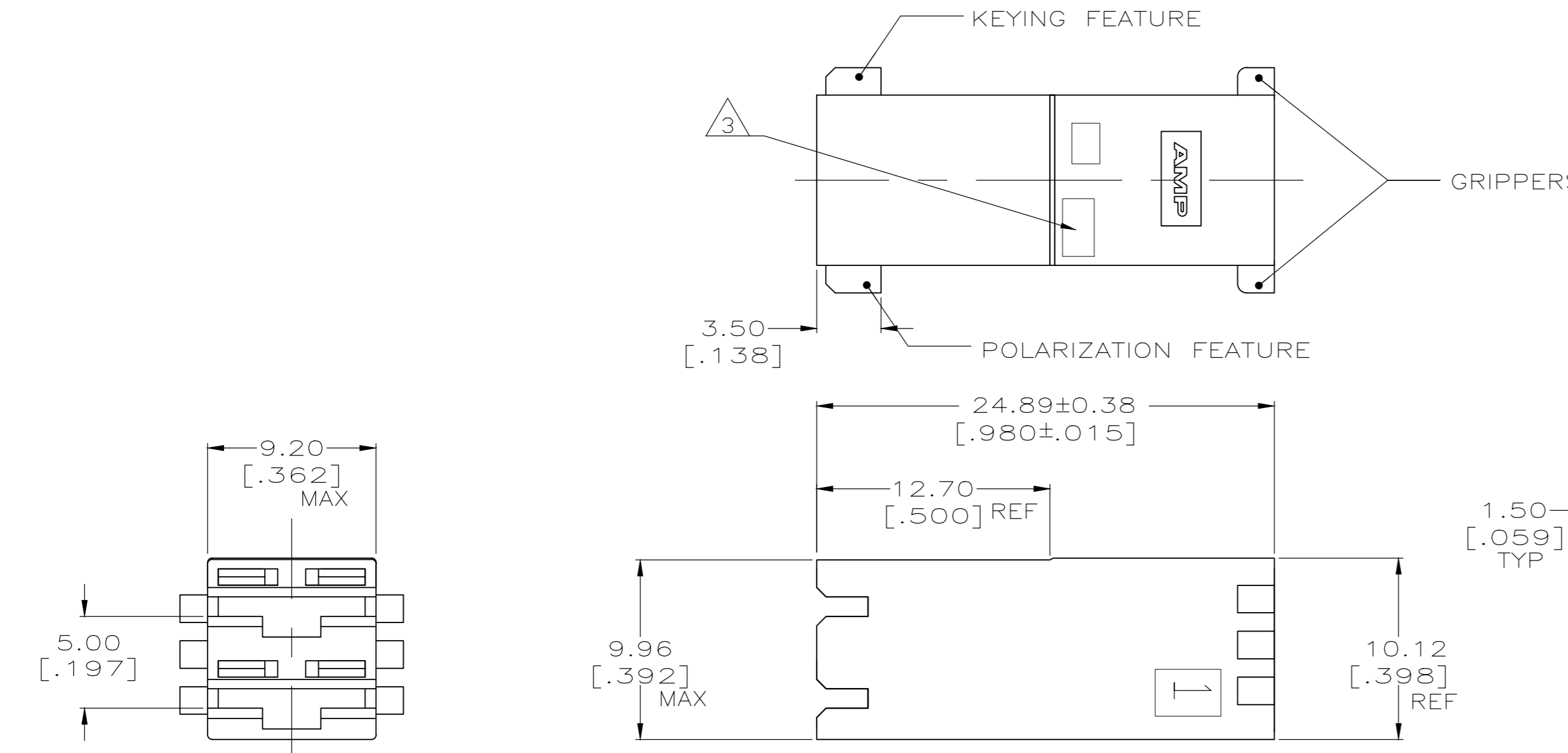

- 1 ACCEPTS RECEPTACLE CONTACTS 1217378(#18-#22 AWG SINGLE WIRE), 1217094(#18-#14 AWG SINGLE WIRE) AND 1217095 (TWO #18'S OR TWO #16'S OR A #16 + #18 COMBINATION).
- 2 FRONT AND BACK VIEWS SHOW ONLY THE GRIPPERS. FOR KEYING AND POLARIZATION FEATURES, SEE SPECIAL FRONT VIEW.
- 3 DFE SYMBOL
- 4 PRELIMINARY - NOT FOR PRODUCTION
- 5 NOTE DELETED
- 6 PRE-PRODUCTION - FASR REQUIRED
- 7 GWEPT 750C NO FLAME

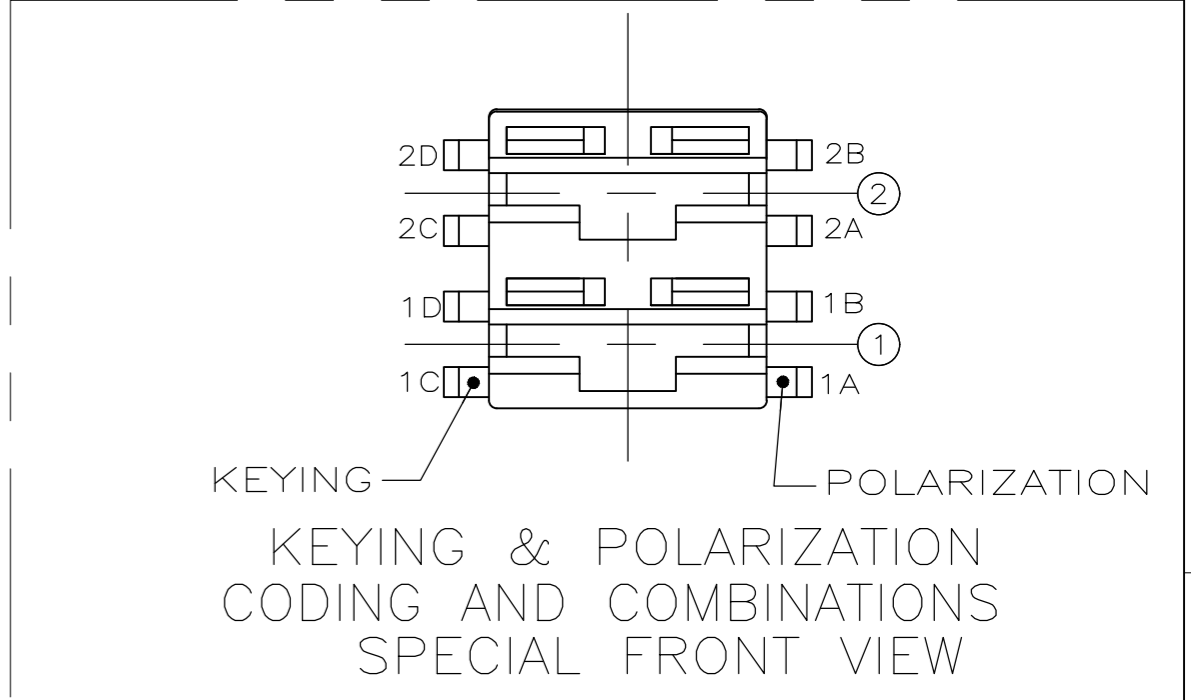

RAST CONFIGURATION	FINISH/COLOR	KEYING FEATURE	POLARIZATION FEATURES	PART NO.
02-B	NATURAL	1C	1A & 2B	1-521204-7
02-E	NATURAL	2D	1A & 2B	1-521204-6
02-A	NATURAL	1C,2D	1B & 2A	1-521204-5
-	NATURAL	NONE	NONE	1-521204-4
02-A	NATURAL	1C,2D	1B & 2A	1-521204-2
02-A	NATURAL	1C,2D	1B & 2A	1-521204-1
-	BLUE	1C,2D	1A,1B,2A,2B	1-521204-0
02-C	BLUE	1C,2D	2A	521204-9
02-K	BLUE	1C	1A & 2A	521204-8
02-B	BLUE	1C	1A & 2B	521204-7
02-A	BLUE	1C,2D	1B & 2A	521204-6
-	BLUE	NONE	NONE	521204-5
-	NATURAL	1D	1A & 2B	521204-4
02-E	NATURAL	2D	1A & 2B	521204-3
-	BLUE	1D	1A & 2B	521204-2
02-E	BLUE	2D	1A & 2B	521204-1

THIS DRAWING IS A CONTROLLED DOCUMENT.

DWN: JR RUTH 10/20/98
 CHK: MS FEHER 10/20/98
 APVD: J GILLESPIE 10/20/98

TE Connectivity

HOUSING, RECEPT, POSITIVE-LOCK, MKIII, 6.35 [.250] SERIES, 2 POSITION

SIZE: A2 CAGE CODE: 00779 DRAWING NO: 521204 RESTRICTED TO: -

MATERIAL: NYLON 3 FINISH: SEE TABLE WEIGHT: CUSTOMER DRAWING SCALE: 4:1 SHEET: 1 OF 1 REV: AB