

	13	12	11	10	9	8	7	6	5	4	3	2	1
J	WIRE SIZE	MAX INSULATION	"A" ±.012 ±0.30	"C" ±.012 ±0.30	"D" ±.005 ±0.13	"E" ±.012 ±0.30	"G" ±.005 ±0.13	"H" ±.012 ±0.30					
	20-24	.073/1.85	.090/2.29	.100/2.54	.030/0.76	.075/1.91	.025/0.64	.082/2.08					
	26-30	.050/1.27	.075/1.91	.083/2.10	.025/0.64	.058/1.47	.020/0.51	0.65/1.65					

MATERIAL NUMBER	PLATING	WIRE SIZE	FORM
45773-0053	A	20-24	CHAIN

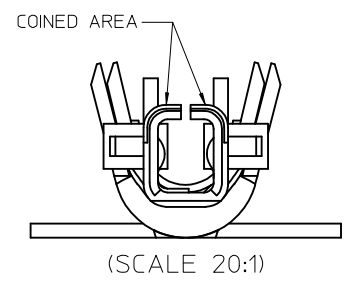
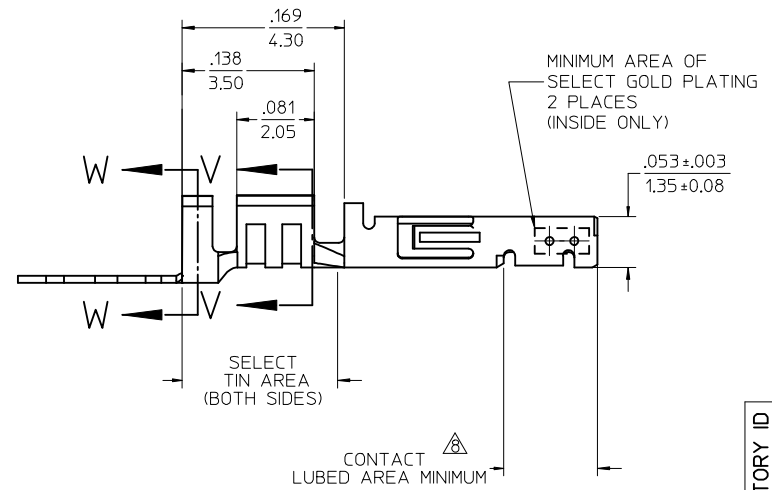
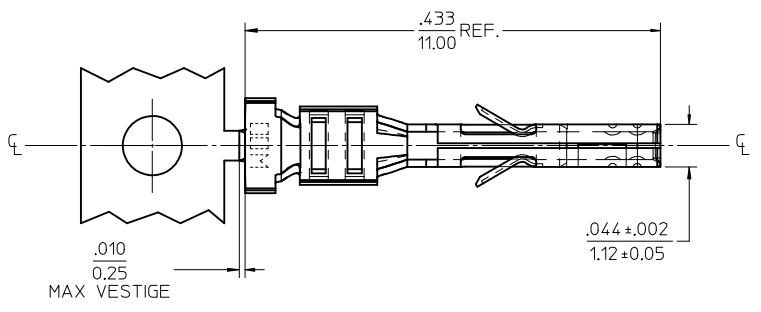
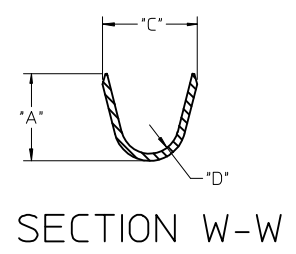
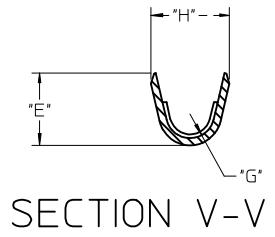

NOTES

- 1) MATERIAL: PHOSPHOR BRONZE ALLOY
- 2) TERMINAL PLATING:  
 \*A\* - .000030/0.00076 MIN. SELECT GOLD  
 .000100/0.00254 MIN. SELECT TIN  
 ALL OVER .000050/0.00127 MIN. NICKEL OVERALL.  
 MATERIAL NUMBERS WITH SELECT PLATING ARE POST-PLATED.
- 3) PRODUCT SPECIFICATION: PS-43045, PS-43650, PS-44300-001.
- 4) PACKAGING SPECIFICATION: PK-45773-002
- 5) TERMINAL FOR USE IN MICRO FIT RECEPTACLE SERIES DESIGNED FOR USING THE 43030-\*\*\*\* FEMALE CRIMP TERMINAL.
- 6) FOR TERMINAL ORIENTATION IN RECEPTACLE SEE DRAWING SDA-43025-\*\*\*\* OR SDA-43645-\*\*\*\*.
- 7) THIS TERMINAL IS DESIGNED IN METRIC.
- 8) MOLEX PROPRIETARY CONTACT LUBRICATION EB-1 IS APPLIED IN THE CONTACT AREA BY THE FACTORY.
- 9) MOLEX RECOMMENDS THE USE OF MICRO-FIT TEST PLUG (SERIES 44242) WHENEVER CONTINUITY TESTING IS PERFORMED. TEST PLUGS MUST NOT BE USED TO MAKE OR BREAK UNDER LOAD. MOLEX DOES NOT RECOMMEND USING STANDARD MATING COMPONENTS (SERIES 43020, 43045, 43640, 43650, OR 43031) FOR HARNESS TESTING PURPOSES.
- 10) TEXT ON PART IS FOR REFERENCE ONLY. TEXT AND TEXT LOCATION MAY VARY DEPENDING ON PART NUMBER AND/OR TOOL.

UPDATE FACTORY ID IEC NO: UCP2017-2563 DRWN:ZHARPER 2017/05/31 CHKD: APPR:FSMITH 2017/09/29	QUALITY SYMBOLS	GENERAL TOLERANCES (UNLESS SPECIFIED)	DIMENSION STYLE IN/MM	SCALE 10:1	DESIGN UNITS METRIC	THIRD ANGLE PROJECTION
	▽=0	mm INCH	DRAWN BY DATE PRIDDER 2006/02/20	TITLE	<b>MICRO-FIT (3.0) FEMALE          CRIMP TERMINAL          W/ LUBRICANT, LEAD FREE</b>  <b>molex</b>	SHEET NO. 1 OF 1
	▽=0	4 PLACES ± --- ± ---	CHECKED BY DATE SSOUSEK 2006/02/21			
	▽=0	3 PLACES ± --- ± .010	APPROVED BY DATE FSMITH 2006/02/21			
▽=0	2 PLACES ± 0.25 ± .014					
		1 PLACE ± 0.35 ± ---				
		0 PLACE ± ±				
		ANGULAR ±1/2°	MATERIAL NO. <b>SEE CHART</b>	DOCUMENT NO. <b>SD-45773-002</b>		
		DRAFT WHERE APPLICABLE MUST REMAIN WITHIN DIMENSIONS	SIZE C	THIS DRAWING CONTAINS INFORMATION THAT IS PROPRIETARY TO MOLEX. INCORPORATED AND SHOULD NOT BE USED WITHOUT WRITTEN PERMISSION		

	13	12	11	10	9	8	7	6	5	4	3	2	1
J	WIRE SIZE	MAX INSULATION	"A" ±.012 ±0.30	"C" ±.012 ±0.30	"D" ±.005 ±0.13	"E" ±.012 ±0.30	"G" ±.005 ±0.13	"H" ±.012 ±0.30					
	20-24	.073/1.85	.090/2.29	.100/2.54	.030/0.76	.075/1.91	.025/0.64	.082/2.08					
	26-30	.050/1.27	.075/1.91	.083/2.10	.025/0.64	.058/1.47	.020/0.51	0.65/1.65					

MATERIAL NUMBER	PLATING	WIRE SIZE	FORM
45773-0053	A	20-24	CHAIN

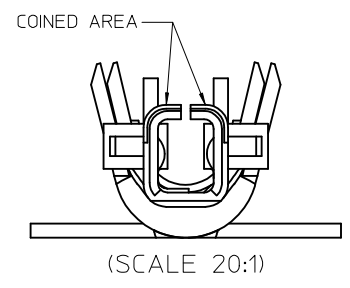
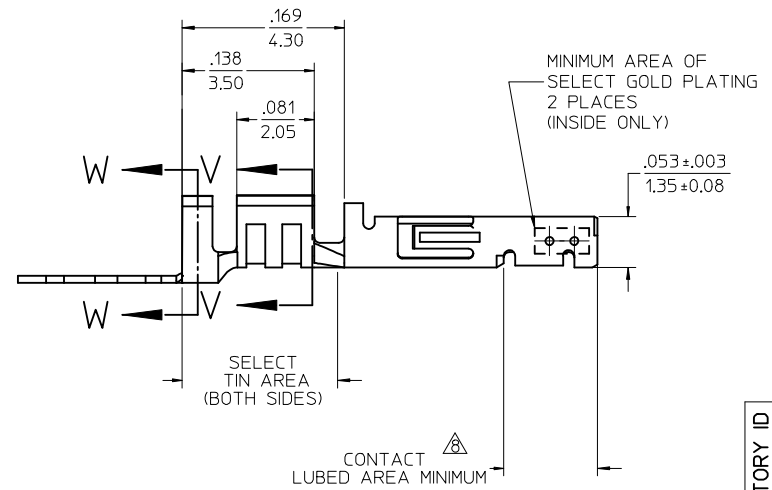
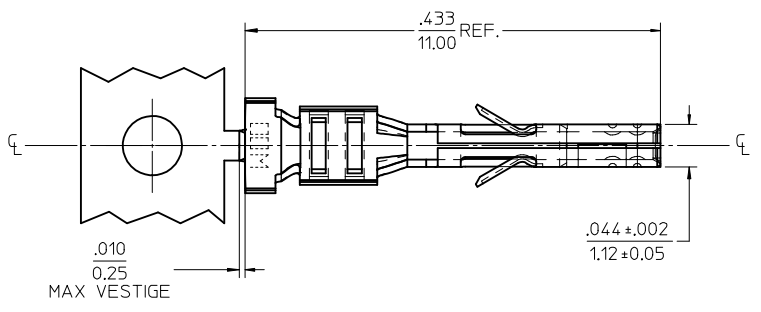
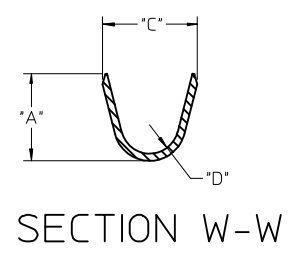
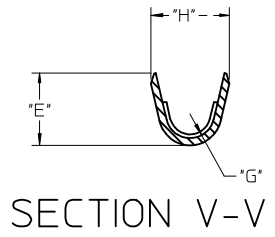

NOTES

- 1) MATERIAL: PHOSPHOR BRONZE ALLOY
- 2) TERMINAL PLATING:  
 \*A\* - .000030/0.00076 MIN. SELECT GOLD  
 .000100/0.00254 MIN. SELECT TIN  
 ALL OVER .000050/0.00127 MIN. NICKEL OVERALL.  
 MATERIAL NUMBERS WITH SELECT PLATING ARE POST-PLATED.
- 3) PRODUCT SPECIFICATION: PS-43045, PS-43650, PS-44300-001.
- 4) PACKAGING SPECIFICATION: PK-45773-002
- 5) TERMINAL FOR USE IN MICRO FIT RECEPTACLE SERIES DESIGNED FOR USING THE 43030-\*\*\*\* FEMALE CRIMP TERMINAL.
- 6) FOR TERMINAL ORIENTATION IN RECEPTACLE SEE DRAWING SDA-43025-\*\*\*\* OR SDA-43645-\*\*\*\*.
- 7) THIS TERMINAL IS DESIGNED IN METRIC.
- 8) MOLEX PROPRIETARY CONTACT LUBRICATION EB-1 IS APPLIED IN THE CONTACT AREA BY THE FACTORY.
- 9) MOLEX RECOMMENDS THE USE OF MICRO-FIT TEST PLUG (SERIES 44242) WHENEVER CONTINUITY TESTING IS PERFORMED. TEST PLUGS MUST NOT BE USED TO MAKE OR BREAK UNDER LOAD. MOLEX DOES NOT RECOMMEND USING STANDARD MATING COMPONENTS (SERIES 43020, 43045, 43640, 43650, OR 43031) FOR HARNESS TESTING PURPOSES.
- 10) TEXT ON PART IS FOR REFERENCE ONLY. TEXT AND TEXT LOCATION MAY VARY DEPENDING ON PART NUMBER AND/OR TOOL.

UPDATE FACTORY ID EC NO: UCP2017-2563 DRWN:ZHARPER 2017/05/31 CHKD: APPR:FSMITH 2017/09/29	QUALITY SYMBOLS ▽=0 ▽=0 ▽=0	GENERAL TOLERANCES (UNLESS SPECIFIED)		DIMENSION STYLE IN/MM		SCALE 10:1	DESIGN UNITS METRIC	THIRD ANGLE PROJECTION	
		mm	INCH	DRAWN BY PRIDDER	DATE 2006/02/20	TITLE MICRO-FIT (3.0) FEMALE CRIMP TERMINAL W/ LUBRICANT, LEAD FREE	molex		
B2	DESCRIPTION REV	4 PLACES	± .010	± .010	CHECKED BY SSOUSEK	DATE 2006/02/21	DOCUMENT NO. SD-45773-002		
		3 PLACES	± .010	± .010	APPROVED BY FSMITH	DATE 2006/02/21	SHEET NO. 1 OF 1		
DRAFT WHERE APPLICABLE MUST REMAIN WITHIN DIMENSIONS		ANGULAR ±1/2°		SEE CHART		THIS DRAWING CONTAINS INFORMATION THAT IS PROPRIETARY TO MOLEX. INCORPORATED AND SHOULD NOT BE USED WITHOUT WRITTEN PERMISSION			