

Features

- Two independent clock channels
- Programmable synthesizers generate any clock-rate from 1 kHz to 720 MHz
- One precision synthesizers generate clocks with jitter below 0.7 ps RMS for 10 G PHYs
- One general purpose synthesizers generate a wide range of digital bus clocks
- Programmable digital PLLs synchronize to any clock rate from 1 kHz to 720 MHz
- Flexible two-stage architecture translates between arbitrary data rates, line coding rates and FEC rates
- Digital PLLs filter jitter from 14 Hz, 28 Hz, 56 Hz, 112 Hz, 224 Hz, 448 Hz or 896 Hz
- Automatic hitless reference switching and digital holdover on reference fail
- Four reference inputs configurable as single ended or differential
- Eight LVPECL outputs and four LVCMOS outputs

Ordering Information

ZL30157GGG2 100 Pin CABGA* Trays
 *Pb Free Tin/Silver/Copper
 -40°C to +85°C

- Eight outputs configurable as LVCMOS or LVDS/LVPECL/HCSL
- Operates from a single crystal resonator or clock oscillator
- Configurable via SPI/I2C interface

Applications

- 10 Gigabit line cards
- Synchronous Ethernet, 10 GBASE-R and 10 GBASE-W
- OTN multiplexers and transponders
- SONET/SDH, Fibre Channel, XAUI

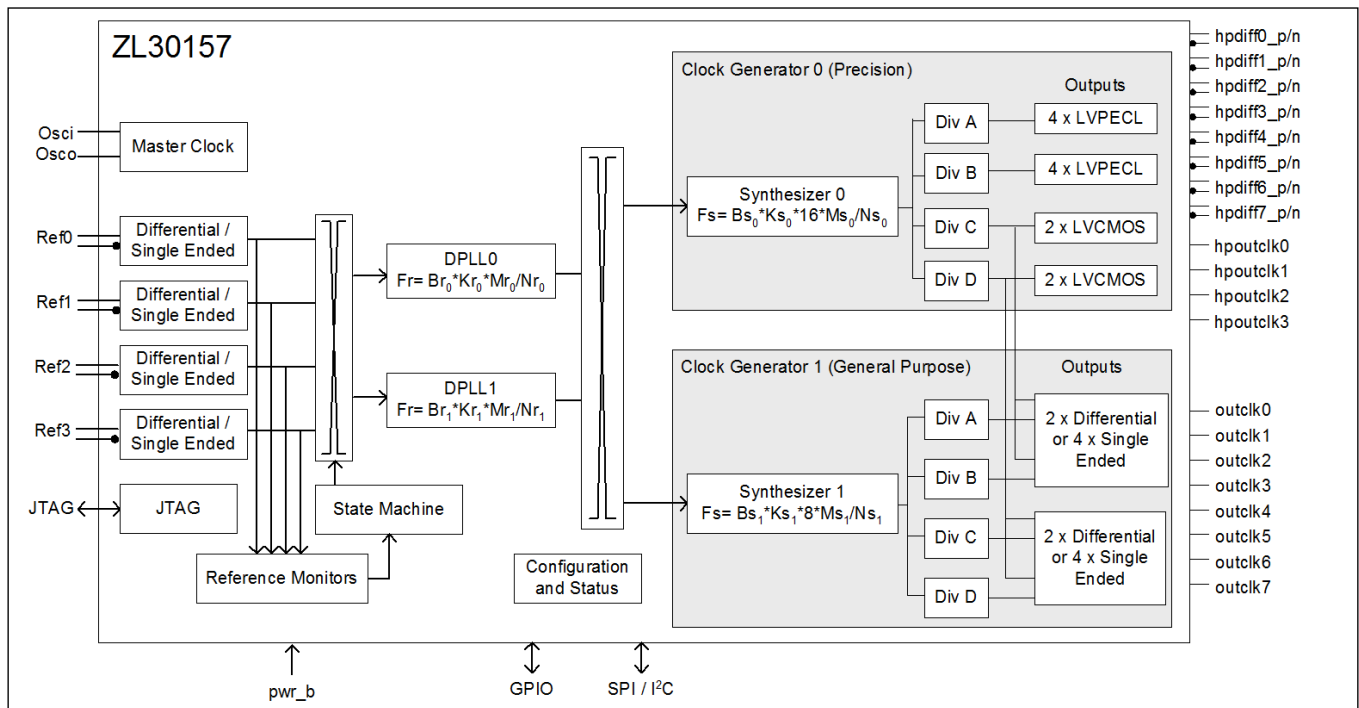

Figure 1 - Functional Block Diagram

Description

The ZL30157 Dual Channel Universal Clock Translator, part of ClockCenter platform of Synchronous Clock devices by Microsemi®, delivers industry leading synchronization performance for high-speed complex applications. The highly integrated and programmable solution provides translation from any input reference frequency to any output clock frequency and allows designers to replace multiple components with a single chip, simplifying design, and reducing component count and power.

The ZL30157 integrates two independent digital phase-locked loops (PLLs), accepts 4 input references, and generates 12 programmable clock outputs. One precision synthesizers generates clocks with jitter performance that can directly drive 10 G PHY devices. One general purpose synthesizers generates a wide range of digital bus clocks.

1.0 Mechanical Drawing

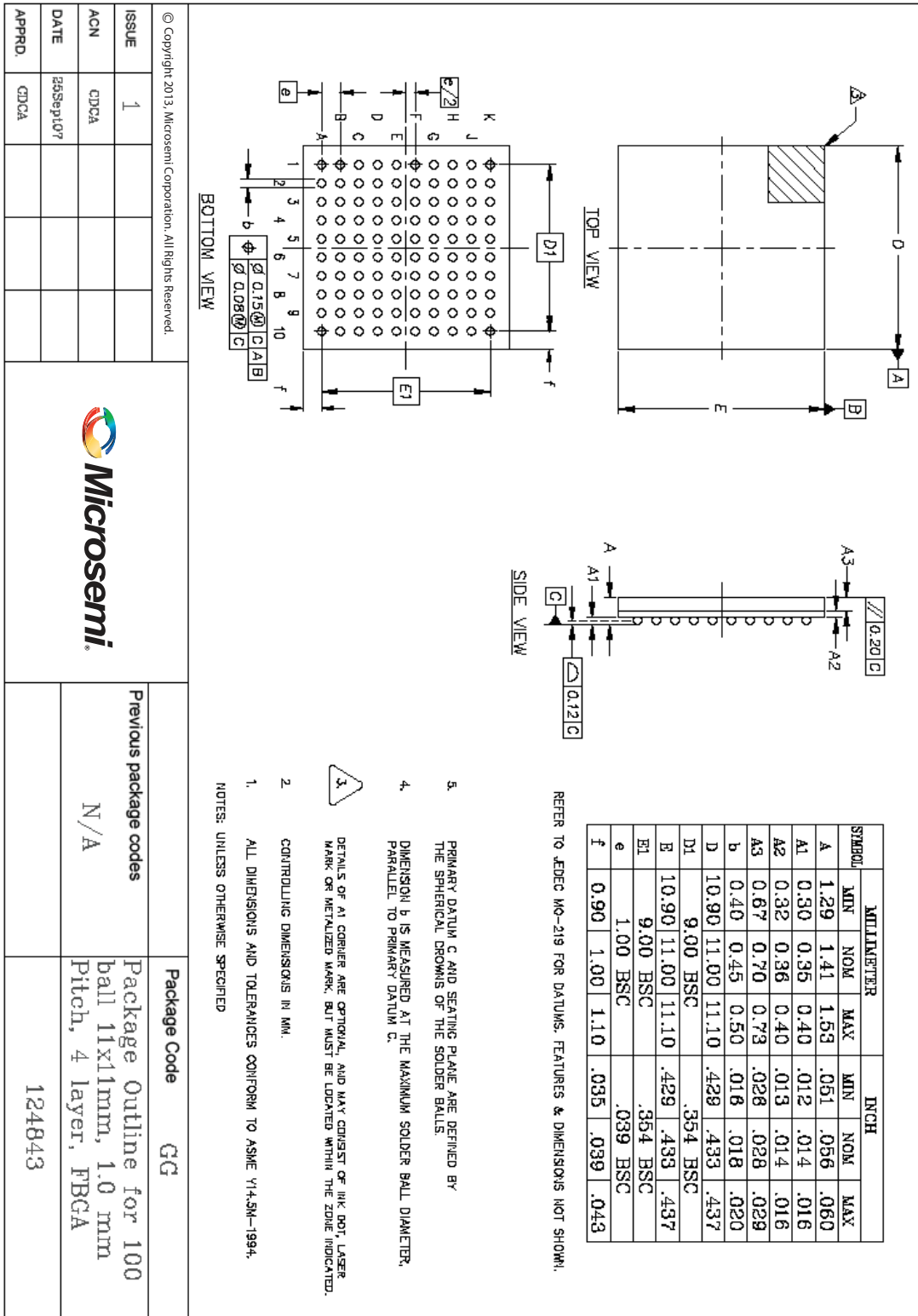

Information relating to products and services furnished herein by Microsemi Corporation or its subsidiaries (collectively "Microsemi") is believed to be reliable. However, Microsemi assumes no liability for errors that may appear in this publication, or for liability otherwise arising from the application or use of any such information, product or service or for any infringement of patents or other intellectual property rights owned by third parties which may result from such application or use. Neither the supply of such information or purchase of product or service conveys any license, either express or implied, under patents or other intellectual property rights owned by Microsemi or licensed from third parties by Microsemi, whatsoever. Purchasers of products are also hereby notified that the use of product in certain ways or in combination with Microsemi, or non-Microsemi furnished goods or services may infringe patents or other intellectual property rights owned by Microsemi.

This publication is issued to provide information only and (unless agreed by Microsemi in writing) may not be used, applied or reproduced for any purpose nor form part of any order or contract nor to be regarded as a representation relating to the products or services concerned. The products, their specifications, services and other information appearing in this publication are subject to change by Microsemi without notice. No warranty or guarantee express or implied is made regarding the capability, performance or suitability of any product or service. Information concerning possible methods of use is provided as a guide only and does not constitute any guarantee that such methods of use will be satisfactory in a specific piece of equipment. It is the user's responsibility to fully determine the performance and suitability of any equipment using such information and to ensure that any publication or data used is up to date and has not been superseded. Manufacturing does not necessarily include testing of all functions or parameters. These products are not suitable for use in any medical and other products whose failure to perform may result in significant injury or death to the user. All products and materials are sold and services provided subject to Microsemi's conditions of sale which are available on request.

**For more information about all Microsemi products
visit our website at
www.microsemi.com**

TECHNICAL DOCUMENTATION – NOT FOR RESALE



Microsemi Corporate Headquarters
One Enterprise, Aliso Viejo CA 92656 USA
Within the USA: +1 (949) 380-6100
Sales: +1 (949) 380-6136
Fax: +1 (949) 215-4996

Microsemi Corporation (NASDAQ: MSCC) offers a comprehensive portfolio of semiconductor solutions for: aerospace, defense and security; enterprise and communications; and industrial and alternative energy markets. Products include high-performance, high-reliability analog and RF devices, mixed signal and RF integrated circuits, customizable SoCs, FPGAs, and complete subsystems. Microsemi is headquartered in Aliso Viejo, Calif. Learn more at www.microsemi.com.

© 2013 Microsemi Corporation. All rights reserved. Microsemi and the Microsemi logo are trademarks of Microsemi Corporation. All other trademarks and service marks are the property of their respective owners.