

Triple Output, Low-Noise LDO Regulator with Integrated Reset Circuit

The ISL6416 is an ultra low noise triple output LDO regulator with microprocessor reset circuit and is optimized for powering wireless chip sets. The IC accepts an input voltage range of 3.0V to 3.6V and provides three regulated output voltages: 1.8V (LDO1), 2.8V (LDO2), and another ultra-clean 2.8V (LDO3). On chip logic provides sequencing between LDO1 and LDO2 for the BBP/MAC and the I/O supply voltage outputs. LDO3 features ultra low noise that does not exceed $30\mu\text{V}_{\text{RMS}}$ (typical) to aid VCO stability. High integration makes the ISL6416 an ideal choice to power many of today's small form factor industry standard wireless cards such as PCMCIA, mini-PCI and Cardbus-32.

The ISL6416 uses an internal PMOS transistor as the pass device. The ISL6416 also integrates a reset function, which eliminates the need for the additional reset IC required in WLAN applications. The IC asserts a RESET signal whenever the VIN supply voltage drops below a preset threshold, keeping it asserted for at least 25ms after Vin has risen above the reset threshold. FAULT indicates the loss of regulation on LDO1.

Ordering Information

PART NUMBER	TEMP. RANGE (°C)	PACKAGE	PKG. DWG. #
ISL6416IA	-40 to +85	16 Ld QSOP	M16.15A
ISL6416IAZ (Note 1)	-40 to +85	16 Ld QSOP (Pb-free)	M16.15A

NOTES:

1. Tape and Reel available. Add "-T" suffix for Tape and Reel Packing Option.
2. Intersil Pb-free products employ special Pb-free material sets; molding compounds/die attach materials and 100% matte tin plate termination finish, which are RoHS compliant and compatible with both SnPb and Pb-free soldering operations. Intersil Pb-free products are MSL classified at Pb-free peak reflow temperatures that meet or exceed the Pb-free requirements of IPC/JEDEC J STD-020C.

Features

- Three LDOs and a RESET circuit
- High Output Current
 - LDO1, 1.8V 330mA
 - LDO2, 2.8V 225mA
 - LDO3, 2.8V 125mA
- Low Output Voltage Noise
 - $<30\mu\text{V}_{\text{RMS}}$ (typical) for LDO3 (VCO Supply)
- Stable with Small Ceramic Output Capacitors
- Extensive Protection and Monitoring Features
 - Overcurrent protection
 - Short circuit protection
 - Thermal shutdown
 - FAULT indicator
- Logic-Controlled Shutdown Pin
- Integrated Microprocessor Reset Circuit
 - Programmable Reset Delay
- Proven Reference Design for a Total WLAN System Solution
- Pb-Free Available (RoHS Compliant)

Applications

- WLAN Cards
 - PCMCIA, Cardbus32, MiniPCI Cards
 - Compact Flash Cards
- Hand-Held Instruments

Pinout and Typical Application Schematic

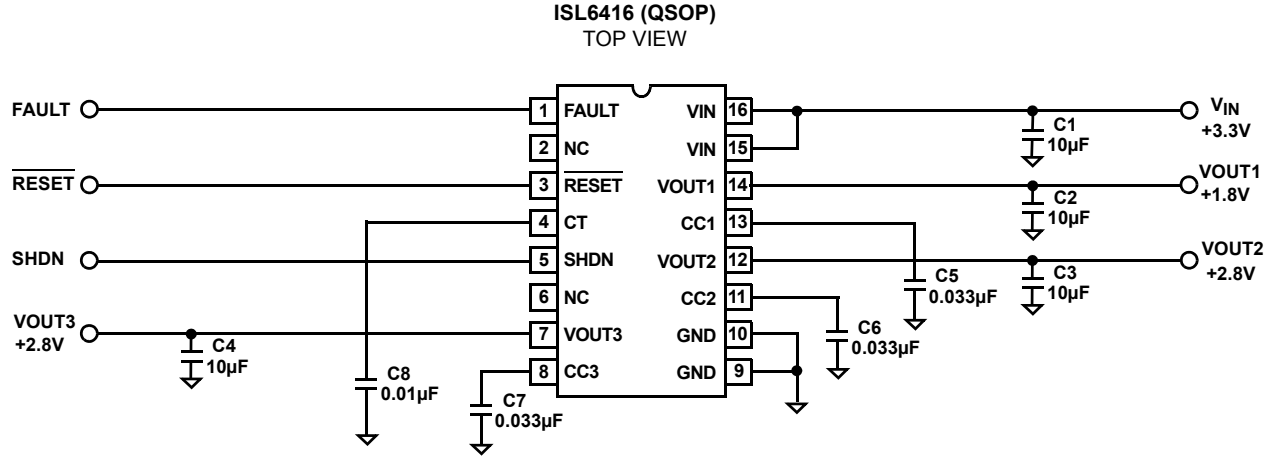

Typical Bill Of Materials

REFERENCE DESIGNATOR	VALUE	PACKAGE	MANUFACTURER	MANUFACTURER'S PART NUMBER
C1, C2, C3, C4	10µF, X7R	1206	TDK	C3216X7R1A106M
C5, C6, C7	0.033µF, X7R	0603	TDK/ANY	C1608X7R1A333K
C8	0.01µF, X7R	0603	TDK/ANY	C1608X7R1A103K
U1	ISL6416IA	QSOP16	Intersil	ISL6416IA

Shrink Small Outline Plastic Packages (SSOP) Quarter Size Outline Plastic Packages (QSOP)

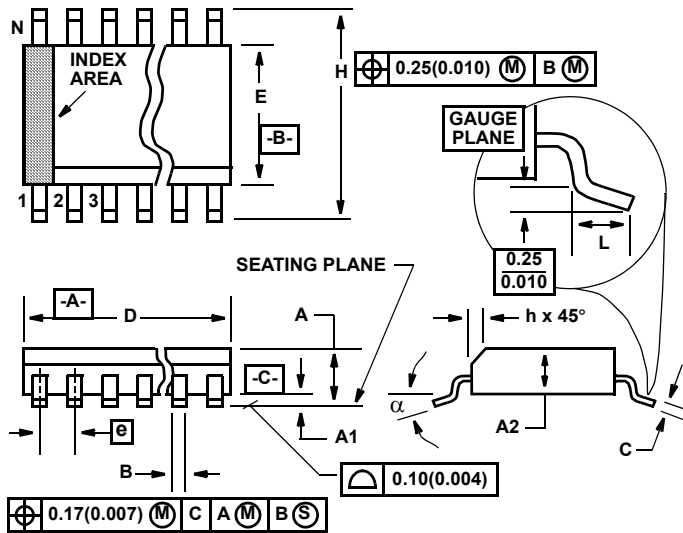

NOTES:

- Symbols are defined in the "MO Series Symbol List" in Section 2.2 of Publication Number 95.
- Dimensioning and tolerancing per ANSI Y14.5M-1982.
- Dimension "D" does not include mold flash, protrusions or gate burrs. Mold flash, protrusion and gate burrs shall not exceed 0.15mm (0.006 inch) per side.
- Dimension "E" does not include interlead flash or protrusions. Interlead flash and protrusions shall not exceed 0.25mm (0.010 inch) per side.
- The chamfer on the body is optional. If it is not present, a visual index feature must be located within the crosshatched area.
- "L" is the length of terminal for soldering to a substrate.
- "N" is the number of terminal positions.
- Terminal numbers are shown for reference only.
- Dimension "B" does not include dambar protrusion. Allowable dambar protrusion shall be 0.10mm (0.004 inch) total in excess of "B" dimension at maximum material condition.
- Controlling dimension: INCHES. Converted millimeter dimensions are not necessarily exact.

M16.15A

**16 LEAD SHRINK SMALL OUTLINE PLASTIC PACKAGE
(0.150" WIDE BODY)**

SYMBOL	INCHES		MILLIMETERS		NOTES
	MIN	MAX	MIN	MAX	
A	0.061	0.068	1.55	1.73	-
A1	0.004	0.0098	0.102	0.249	-
A2	0.055	0.061	1.40	1.55	-
B	0.008	0.012	0.20	0.31	9
C	0.0075	0.0098	0.191	0.249	-
D	0.189	0.196	4.80	4.98	3
E	0.150	0.157	3.81	3.99	4
e	0.025 BSC		0.635 BSC		-
H	0.230	0.244	5.84	6.20	-
h	0.010	0.016	0.25	0.41	5
L	0.016	0.035	0.41	0.89	6
N	16		16		7
α	0°	8°	0°	8°	-

Rev. 2 6/04

All Intersil U.S. products are manufactured, assembled and tested utilizing ISO9000 quality systems.
Intersil Corporation's quality certifications can be viewed at www.intersil.com/design/quality

Intersil products are sold by description only. Intersil Corporation reserves the right to make changes in circuit design, software and/or specifications at any time without notice. Accordingly, the reader is cautioned to verify that data sheets are current before placing orders. Information furnished by Intersil is believed to be accurate and reliable. However, no responsibility is assumed by Intersil or its subsidiaries for its use; nor for any infringements of patents or other rights of third parties which may result from its use. No license is granted by implication or otherwise under any patent or patent rights of Intersil or its subsidiaries.

For information regarding Intersil Corporation and its products, see www.intersil.com

ISL6416



[Printer Friendly Version](#)

Triple Output, Low-Noise LDO Regulator with Integrated Reset Circuit

DS Datasheets, Related Docs & Simulations	Description	Key Features	PT Parametric Data	Application Diagrams	Related Devices
---	-----------------------------	------------------------------	------------------------------------	--------------------------------------	---------------------------------

Ordering Information

 **RoHS/Pb-Free/Green Device**

Part No.	Design-In		Package	Price			
	Status	Temp.		MSL	US \$		
ISL6416IA	Active	Ind	16 Ld QSOP	2	1.36	Buy	Sample
ISL6416IA-TK	Active	Ind	16 Ld QSOP T+R	2	1.36	Buy	
ISL6416IAZ 	Active	Ind	16 Ld QSOP	2	1.36	Buy	Sample
ISL6416IAZ-TK 	Active	Ind	16 Ld QSOP T+R	2	1.36	Buy	

The price listed is the manufacturer's suggested retail price for quantities between 100 and 999 units. However, prices in today's market are fluid and may change without notice.

MSL = Moisture Sensitivity Level - per IPC/JEDEC J-STD-020

SMD = Standard Microcircuit Drawing

 **Description**

The ISL6416 is an ultra low noise triple output LDO regulator with microprocessor reset circuit and is optimized for powering wireless chip sets. The IC accepts an input voltage range of 3.0V to 3.6V and provides three regulated output voltages: 1.8V (LDO1), 2.8V (LDO2), and another ultra-clean 2.8V (LDO3). On chip logic provides sequencing between LDO1 and LDO2 for the BBP/MAC and the I/O supply voltage outputs. LDO3 features ultra low noise that does not exceed 30µVRMS (typical) to aid VCO stability. High integration makes the ISL6416 an ideal choice to power many of today's small form factor industry standard wireless cards such as PCMCIA, mini-PCI and Carbus-32.

The ISL6416 uses an internal PMOS transistor as the pass device. The ISL6416 also integrates a reset function, which eliminates the need for the additional reset IC required in WLAN applications. The IC asserts a RESET signal whenever the VIN supply voltage drops below a preset threshold, keeping it asserted for at least 25ms after Vin has risen above the reset threshold. FAULT indicates the loss of regulation on LDO1.

 **Key Features**

- Three LDOs and a RESET circuit
- High Output Current
 - LDO1, 1.8V 330mA
 - LDO2, 2.8V 225mA
 - LDO3, 2.8V 125mA
- Low Output Voltage Noise
 - <30µVRMS (typical) for LDO3 (VCO Supply)
- Stable with Small Ceramic Output Capacitors
- Extensive Protection and Monitoring Features
 - Overcurrent protection
 - Short circuit protection
 - Thermal shutdown
 - FAULT indicator
- Logic-Controlled Shutdown Pin
- Integrated Microprocessor Reset Circuit
 - Programmable Reset Delay
- Proven Reference Design for a Total WLAN System Solution
- Pb-Free Available (RoHS Compliant)

Related Documentation

Datasheet(s):

- [Triple Output, Low-Noise LDO Regulator with Integrated Reset Circuit](#)

Parametric Data

V_{IN} (min) (V)	3
V_{IN} (max) (V)	3.6
V_{OUT} (min) (V)	1.8
V_{OUT} (max) (V)	2.8
I_{OUT} (max) (mA)	500

Application Block Diagrams

- [DSL Modem \(CPE\)](#)
- [Desktop Computers](#)
- [E-Power Meter](#)
- [Fingerprint Biometrics](#)
- [GPS Handheld](#)
- [Game Console](#)
- [IPTV Set-Top Box](#)
- [Keyboard Video Mouse \(KVM\)](#)
- [Medical Telemetry](#)
- [Notebook Computers](#)
- [Portable Digital Assistant \(PDA\)](#)
- [Voice over IP \(VoIP\) Phone](#)

Applications

- WLAN Cards
 - PCMCIA, Cardbus32, MiniPCI Cards
 - Compact Flash Cards
- Hand-Held Instruments

Related Devices

 [Parametric Table](#)

EL7530	Monolithic 600mA Step-Down Regulator with Low Quiescent Current
EL7531	Monolithic 1A Step-Down Regulator with Low Quiescent Current
EL7534	Monolithic 600mA Step-Down Regulator
EL7536	Monolithic 1A Step-Down Regulator
ICL7663S	CMOS Programmable Micropower Positive Voltage Regulator
ISL6410	Single Synchronous Buck Regulator with Integrated FET for WLAN Chipsets
ISL6410A	Single Synchronous Buck Regulator with Integrated FET for WLAN Chipsets
ISL6412	Triple Output, Low-Noise LDO Regulator with Integrated Reset Circuit
ISL6413	Triple Output Regulator with Single Synchronous Buck and Dual LDO
ISL6414	Triple Output, Low-Noise LDO Regulator with Integrated Reset Circuit
ISL6455	0.6A PWM Regulator and Dual 0.3A LDOs and Reset
ISL6455A	0.6A PWM Regulator and Dual 0.3A LDOs and Reset
ISL6719	100V Linear Bias Supply
ISL6720A	100V Triple Linear Bias Supply
ISL9000	Dual LDO with Low Noise, Very High PSRR, and Low I_Q
ISL9000A	Dual LDO with Low Noise, Very High PSRR, and Low I_Q
ISL9001	LDO with Low I_{SUPPLY} , High PSRR
ISL9001A	LDO with Low I_{SUPPLY} , High PSRR
ISL9003A	Low Noise LDO with Low I_Q , High PSRR
ISL9005	LDO with Low I_{SUPPLY} , High PSRR
ISL9005A	LDO with Low I_{SUPPLY} , High PSRR
ISL9007	High Current LDO with Low I_Q and High PSRR
ISL9008A	Low Noise LDO with Low I_Q , High PSRR

<u>ISL9011</u>	Dual LDO with Low Noise, Low I _Q , and High PSRR
<u>ISL9011A</u>	Dual LDO with Low Noise, Low IQ, and High PSRR
<u>ISL9012</u>	Dual LDO with Low Noise, Low I _Q , and High PSRR
<u>ISL9014</u>	Dual LDO with Low Noise, Low I _Q , and High PSRR
<u>ISL9014A</u>	Dual LDO with Low Noise, Low IQ, and High PSRR