

Dual Axis Programmable Tilt Switch

Part Number: 0729-1736-99

Operating Specifications¹

Output	1 relay
Supply Voltage	7 V DC to 30 V DC
Supply Current	30 mA @ 12 V DC
Operating Range	±35°
Minimum Trip Angle	±1°
Axes of Measurement	2
Null Offset	≤5°
Repeatability	±0.1°
Trip Accuracy	±0.2°
Output Trip Delay (default, settable)	1 s
Output Return Delay (default, settable)	0.5 s
Output Hysteresis (default, settable)	0.25°
Output Filter (default, settable)	0 s
Cross Axis (Roll) Sensitivity	≤0.025° per degree
Long Term Stability/Drift	≤0.1°
Operating Temperature	-35 °C to 70 °C
Storage Temperature	-40 °C to 70 °C

Dimensions

Housing	ABS Plastic
Electrical Connections	18" cable with 24 gauge wire
Weight	150 g
Length	53 mm (2.102")
Width	79 mm (3.117")
Height	27 mm (1.075")
Flange Length	24 mm (0.936")
Hole Center	89 mm (3.500")
Hole Diameter	5 mm (0.188")

Electrical Connections

Red	Supply (7 V DC to 30 V DC)
Black	Supply (-)
Orange	Zero wire
Green	Relay (C)
Violet	Relay (NO)
Blue	Relay (NC)
Brown	RS-232 receive (RX)
Yellow	RS-232 transmit (TX)

Relay Output Description

The relay is (closed or open) when un-tripped and (closed or open) when tripped. This relay polarity can be reversed using digital communications or pre-programmed at the factory. The relay is SPDT and rated for 2A at 30 V DC.

Benefits

- Very low power consumption
- Simple integration
- Excellent measurement resolution and accuracy
- Superior performance in extreme environments
- Excellent customer support
- Designed and manufactured in the United States of America

¹ Visit www.frederickscompany.com for a list of definitions.



Description

The 0729-1736-99 Dual Axis Programmable Tilt Switch utilizes a 0717-4319-99 Fredericks TrueTilt™ wide range electrolytic tilt sensor and signal conditioner. Its robust plastic housing and epoxy potting provide excellent durability and environmental protection. This tilt switch has superior accuracy and unit to unit performance with a low profile and economic design making it an ideal solution for a versatile range of applications in many sectors.

The RS-232 communications included standard with this tilt switch allow access to several settable features making it simple to integrate into any system.

Applications

- Construction vehicles
- Boom angle measurement
- Agricultural vehicles
- Vehicle tip over prevention
- Aerial lift and work platform, boom lift, crane, forklift, scissor lift, and telehandler/telescopic handler operator safety and tip over prevention

View a full list of applications on The Fredericks Company website at www.frederickscompany.com.

Certifications and Ratings

- RoHS Compliant
- IP66

Direction of Measurement

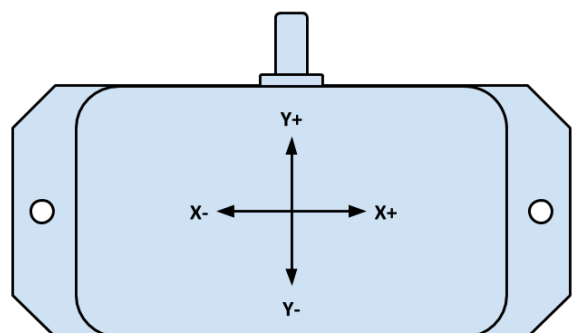

Dual Axis Programmable Tilt Switch

Part Number: 0729-1736-99



RS-232 Settings

Baud Rate	9600
Data Bits	8
Parity	None
Stop Bits	1

Mounting Notes

The 0729-1736-99 and all tilt switches in this series must be mounted horizontally (parallel to the surface of the earth and perpendicular to the force of gravity). For best performance, isolate the unit from vibrations when mounting it.

Related Products

Tilt Switches

0729-1758-99	±45° range, single axis, 2 open collector outputs
0729-1759-99	±45° range, single axis, 2 open collector outputs

0729 series inclinometers - Inclinometers provide a continuous output of tilt angle position instead of the on/off functionality of the tilt switch. Our inclinometers in this series utilize Fredericks TrueTilt™ wide range electrolytic tilt sensors. They have a variety of output options including analog 0 to 5 V DC, CAN Bus SAE J1939, RS-232, and RS-485. These inclinometers have a low profile and robust plastic housing with epoxy potting to provide excellent durability and environmental protection.

Wiring Example

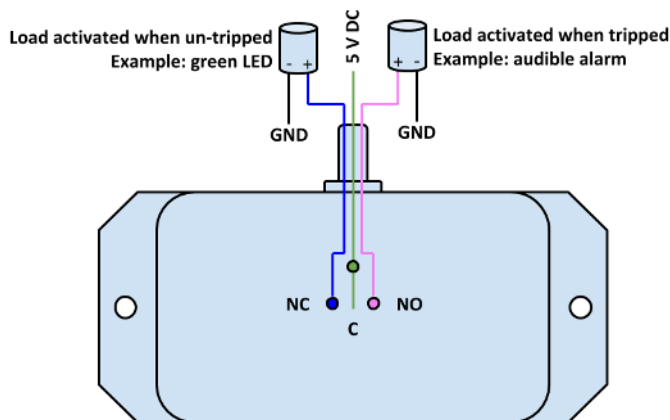

Notes on this example:

1. This assumes the default polarity for the relay (setting of 0). If the relay polarity is changed through RS-232 communications or by the factory at the time of order (setting of 1), the load connected to the violet wire will be activated in the un-tripped state and the load connected to the blue wire will be activated in the tripped state.
2. Always be sure to observe the load polarity before connecting it and ensure that the 0729-1736-99 relay current rating of 2A at 30 V DC is not exceeded.

Dimensional Drawings

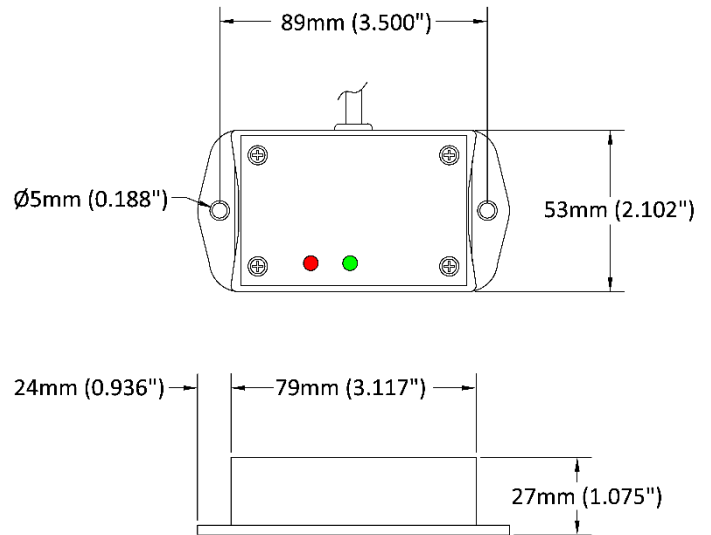

RS-232 Commands (commands are case sensitive)

'?'	Show a list of all commands
'set'	Enter setup mode
'x'	Change x axis trip angle
'y'	Change y axis trip angle
'+'	Increment selected axis trip angle by 0.1°
'-'	Decrement selected axis trip angle by 0.1°
'S'	Save selected trip angles
'Z'	Set and save a new zero position
'd'	Change and save trip delay (0 to 9)
'r'	Change and save return delay (0 to 9)
'p'	Change and save relay polarity (0 to 9)
'h'	Change and save hysteresis value (1 to 8)
'f'	Change and save filter value (0 to 9)
'q'	Show all settings
Esc	Cancel the current command

Contact Us

The Fredericks Company
 2400 Philmont Avenue
 Huntingdon Valley, PA 19006
 tel: +1 215 947 2500
 fax: +1 215 947 7464

email: sales@frederickscompany.com
 web: www.frederickscompany.com

Disclaimer: Specifications subject to change without notice. The Fredericks Company assumes no responsibility for inaccuracies in product specifications or any liability arising from product use.
 © 2016 The Fredericks Company