

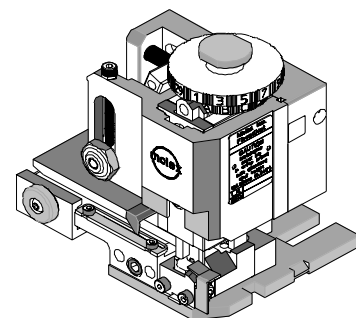

FineAdjust Applicator Specification Sheet Part No. 63863-4000



FEATURES

- Quick punch removal with the push of a button for fast and easy tooling change
- Applicator designed to industry standard mounting and shut height 135.80mm (5.346")
- Quick set-up time; plus the crimp height, track and feed adjustments can be set without removing the applicator from the press
- Fine adjustment allows users to achieve target with little effort by adjusting in increments of 0.15mm (.0006") for conductor crimp height and .063mm (.0025") for insulation height
- Independent adjustment rings allow users to quickly adjust the conductor or insulation crimp height without affecting each other
- Directly adapts to most automatic wire processing machines

SCOPE

Terminal Series No.	Wire Size		Insulation Diameter		Strip Length	
	AWG	mm ²	mm	In.	mm	In.
90198-0001	22 - 26	0.35-0.12	1.52 Max	.060 Max	1.70-2.10	.067-.083
Terminal will accommodate the following wire specification: 22 AWG-Solid Wire or Fused Wire 24-26 AWG Solid Wire, Fused Wire or Stranded Wire						

DEFINITION OF TERMS

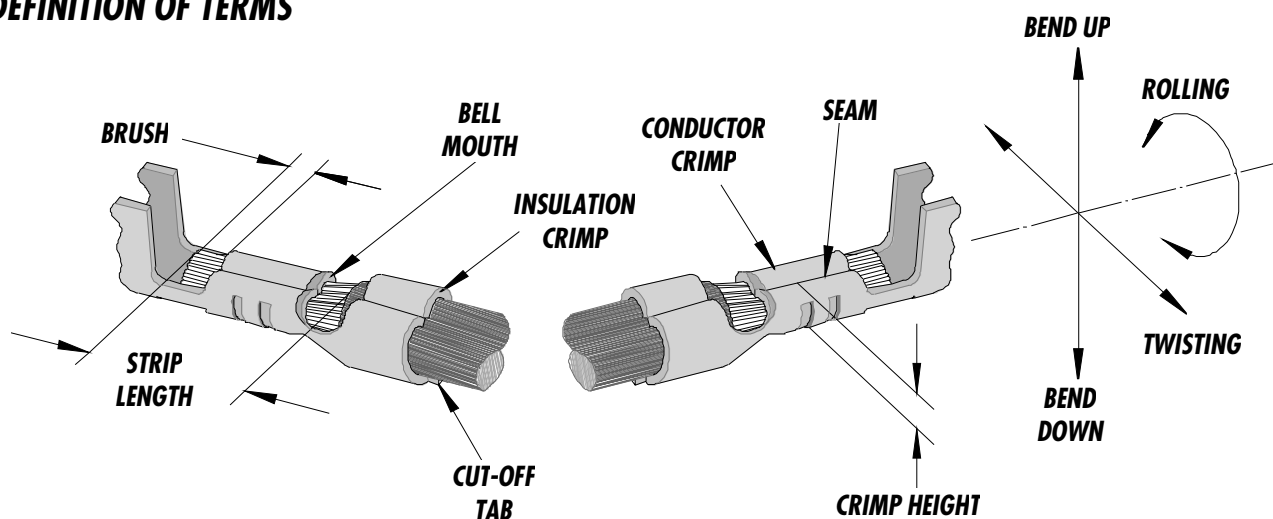

The above terminal drawing is a generic terminal representation. It is not an image of a terminal listed in the scope.

CRIMP SPECIFICATION

Terminal Series No.	Bell mouth		Cut-off Tab Max.		Conductor Brush	
	mm	In.	mm	In.	mm	In.
90198-0001	None	None	0.30	.012	0.00-0.40	.000-.016

Terminal Series No.	Bend up	Bend down	Twist	Roll	Punch Width mm (Ref)				Seam Seam shall not be open and no wire allowed out of the crimping area
	Degree		Degree		Conductor		Insulation		
	mm	In	mm	In	mm	In	mm	In	
90198-0001	N/A	N/A	N/A	N/A	1.00	.039	1.80	.070	

After crimping, the conductor profile should measure the following.

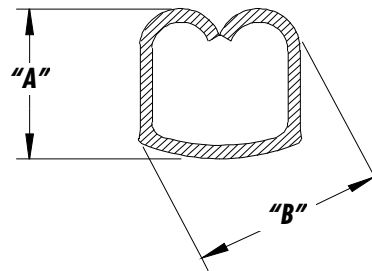

"CRIMP PROFILE"

Terminal Series No.	Wire Size		"A" Crimp Height		"B" Diagonal Dim.		Pull Force Min.	
	AWG	mm ²	mm	In	mm	In.	N	Lb.
90198-0001	22	0.35	0.89 Ref	.035 Ref	1.19 Max	.047 Max	35.6	8.0
90198-0001	24	0.20	0.79 Ref	.031 Ref	1.14 Max	.045 Max	22.2	5.0
90198-0001	26	0.12	0.74 Ref	.029 Ref	1.14 Max	.045 Max	13.3	3.0

Pull Force should be measured with no influence from the insulation crimp.

The above specifications are guidelines to an optimum crimp.

PARTS LIST

Item	Order No	Engineering No.	Description	Quantity
	63863-4000	63863-4000	FineAdjust Applicator (Fig. 1)	REF
1	63457-0002	63457-0002	Conductor Punch	1 Y
2	63455-0006	63455-0006	Conductor Anvil	1 Y
3	63454-0009	63454-0009	Insulation Punch	1 Y
4	63445-1834	63445-1834	Insulation Anvil	1 Y
5	63443-0003	63443-0003	Cut-Off Plunger	1 Y
6	63443-0012	63443-0012	Front Plunger Retainer	1 Y
7	11-24-1067	4996-4	Cut-Off Plunger Spring	1
8	63443-3160	63443-3160	Front Plunger Striker	1
9	63443-0021	63443-0021	Lower Tooling Key	1
10	63443-6003	63443-6003	Rear Cover	1
11	11-18-4083	60707-8	Front Cover	1
12	63443-2420	63443-2420	Anvil Mount	1
13	63443-0009	63443-0009	Scrap Chute	1
14	63443-0054	63443-0054	Stripper Blade	1
15	63800-4900	63800-4900	FineAdjust Applicator	1
16	63443-0053	63443-0053	Stripper Blade Holder	1
17	N/A	N/A	M3 by 6Lg. SHCS	3**
18	N/A	N/A	M4 by 6Lg. SHCS	1**
19	N/A	N/A	M4 by 12Lg. BHCS	2**
20	N/A	N/A	M4 by 16Lg SHCS	1**
21	N/A	N/A	M4 by 20Lg. SHCS	1**
22	N/A	N/A	M4 by 50Lg. SHCS	1**
23	N/A	N/A	3MM by 6Lg. Roll Pin	1**
24	N/A	N/A	#10-32 by 1/4"Lg. BHCS	1**
	63863-4070	63863-4070	Tool Kit (All Y Items)	REF

**** The following purchased parts are available from an Industrial supply company such as MSC (1-800-645-7270).**

Assembly Drawing

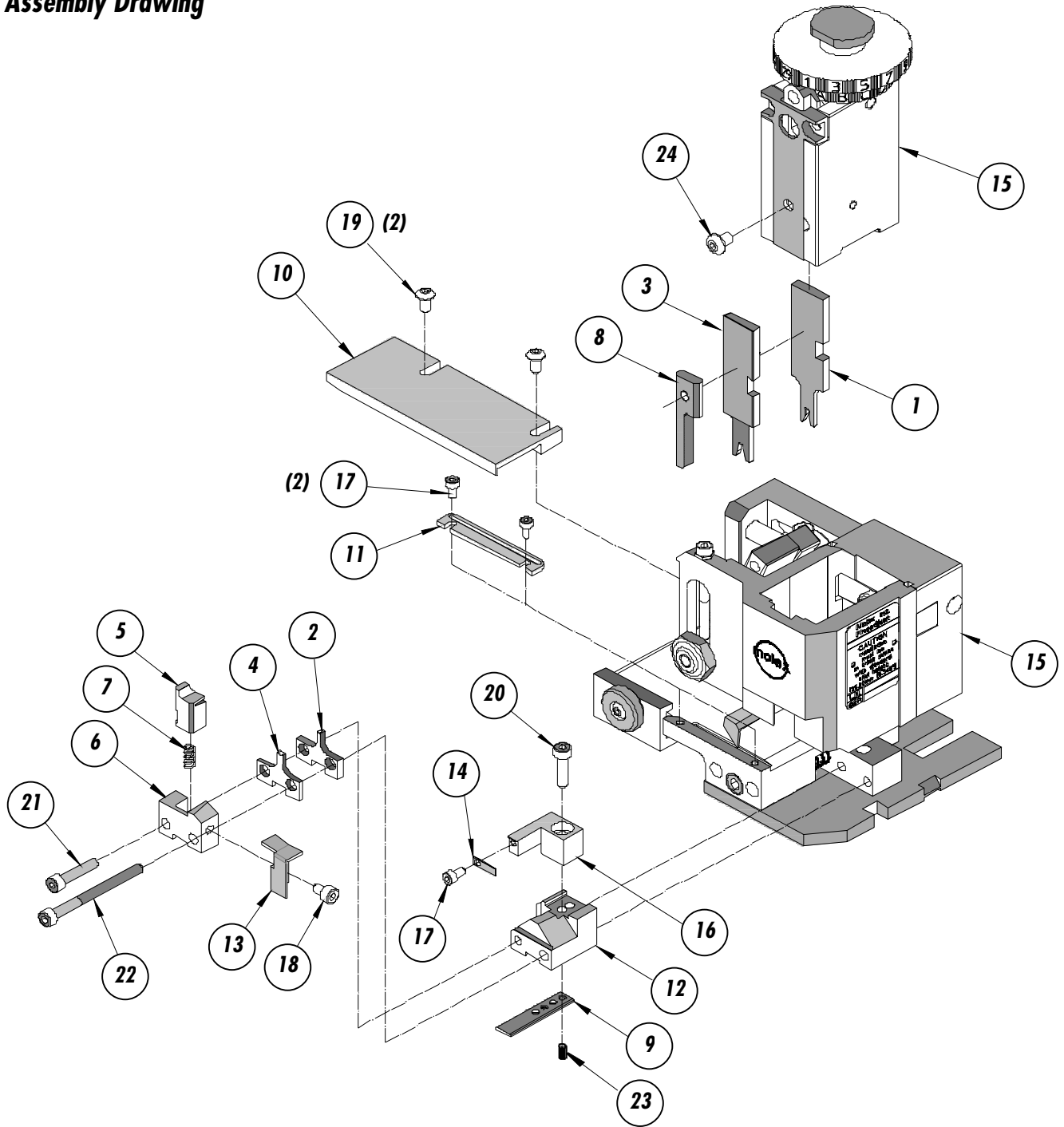

Figure 1

NOTES

1. Molex recommends an extra perishable tooling kit be maintained at your facility.
2. Verify tooling alignment by manually cycling the press and Applicator before crimping under power. Check that all screws are tight.
3. Slugs, Terminals, Dirt and Oil should be kept clear of work area.
4. Wear safety glasses at all times.
5. For recommended maintenance refer to the FineAdjust Manual.

CAUTION: This applicator should only be used in a press with a shut height of 135.8 mm (5.346"). Tooling damage could result at a lower setting.

CAUTION: To prevent injury never operate this Applicator without the guards supplied with the press or wire-processing machine in place. Reference the press or wire processing manufacturer's instruction manual.

CAUTION: Molex crimp specifications are valid only when used with Molex terminals, applicators and tooling.

**Molex Application Tooling Group
1150 E. Diehl Road
Naperville, IL 60563
Tel: (630) 969-4550
Fax: (630) 505-0049**

Visit our Web site at <http://www.molex.com>