

## Low voltage, low current power 8-bit shift register

Datasheet - production data

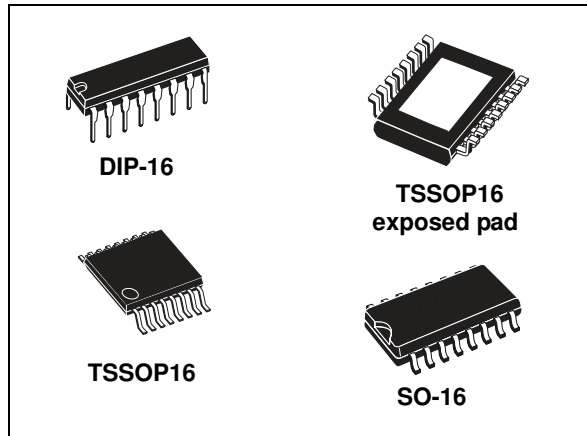

### Description

The STP08CP05 is a monolithic, low voltage, low current, power 8-bit shift register designed for LED panel displays. The STP08CP05 contains an 8-bit serial-in, parallel-out shift register that feeds an 8-bit D-type storage register. In the output stage, eight regulated current sources were designed to provide 5-100 mA constant current to drive the LEDs, the output current setup time is 11 ns (typ), thus improving the system performance.

The STP08CP05 is backward compatible in functionality and footprint with STP8C/L596. Through an external resistor, users can adjust the STP08CP05 output current, controlling in this way the light intensity of LEDs, in addition, user can adjust LED's brightness intensity from 0% to 100% via  $\overline{OE}$  pin.

The STP08CP05 guarantees a 20 V output driving capability, allowing users to connect more LEDs in series. The high clock frequency, 30 MHz, also satisfies the system requirement of high volume data transmission. The 3.3 V of voltage supply is useful for applications that interface with any micro from 3.3 V. Compared with a standard TSSOP package, the TSSOP exposed pad increases heat dissipation capability by a 2.5 factor.

### Features

- Low voltage power supply down to 3 V
- 8 constant current output channels
- Adjustable output current through external resistor
- Serial data IN/parallel data OUT
- 3.3 V micro driver-able
- Output current: 5-100 mA
- 30 MHz clock frequency
- Available in high thermal efficiency TSSOP exposed pad
- ESD protection 2.5 kV HBM, 200 V MM

Table 1. Device summary

Order codes	Package	Packaging
STP08CP05B1R	DIP-16	25 parts per tube
STP08CP05MTR	SO-16 (Tape and reel)	2500 parts per reel
STP08CP05TTR	TSSOP16 (Tape and reel)	2500 parts per reel
STP08CP05XTTR	TSSOP16 exposed pad (Tape and reel)	2500 parts per reel

# Contents

<b>1</b>	<b>Summary description</b> .....	<b>3</b>
	1.1 Pin connection and description .....	3
<b>2</b>	<b>Block diagram</b> .....	<b>4</b>
<b>3</b>	<b>Maximum rating</b> .....	<b>5</b>
	3.1 Absolute maximum ratings .....	5
	3.2 Thermal data .....	5
	3.3 Recommended operating conditions .....	6
<b>4</b>	<b>Electrical characteristics</b> .....	<b>7</b>
<b>5</b>	<b>Switching characteristics</b> .....	<b>8</b>
<b>6</b>	<b>Equivalent circuit and outputs</b> .....	<b>9</b>
<b>7</b>	<b>Truth table and timing diagram</b> .....	<b>11</b>
	7.1 Truth table .....	11
	7.2 Timing diagram .....	11
<b>8</b>	<b>Typical characteristics</b> .....	<b>14</b>
<b>9</b>	<b>Test circuit</b> .....	<b>17</b>
<b>10</b>	<b>Package mechanical data</b> .....	<b>18</b>
<b>11</b>	<b>Packaging mechanical data</b> .....	<b>27</b>
<b>12</b>	<b>Revision history</b> .....	<b>29</b>

# 1 Summary description

**Table 2. Typical current accuracy**

Output voltage	Current accuracy		Output current
	Between bits	Between ICs	
$\geq 1.3$ V	$\pm 1.5\%$	$\pm 3\%$	20 to 100 mA

## 1.1 Pin connection and description

**Figure 1. Connections diagram**

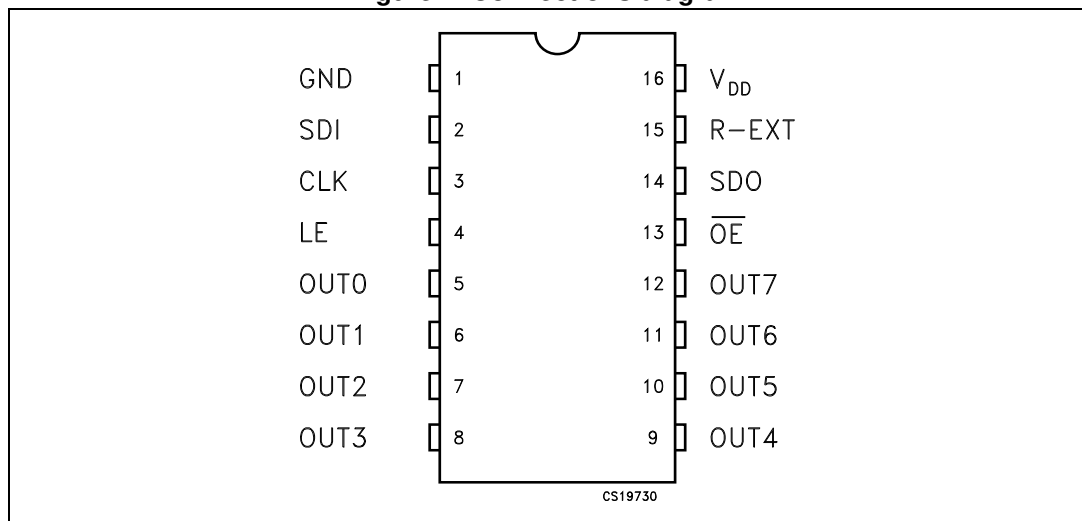

*Note:* The exposed pad should be electrically connected to a metal land electrically isolated or connected to ground.

**Table 3. Pin description**

Pin N°	Symbol	Name and function
1	GND	Ground terminal
2	SDI	Serial data input terminal
3	CLK	Clock input terminal
4	LE	Latch input terminal
5-12	OUT 0-7	Output terminal
13	$\overline{OE}$	Output enable input terminal (active low)
14	SDO	Serial data out terminal
15	R-EXT	Constant current programming
16	$V_{DD}$	5 V supply voltage terminal

## 2 Block diagram

Figure 2. Block diagram

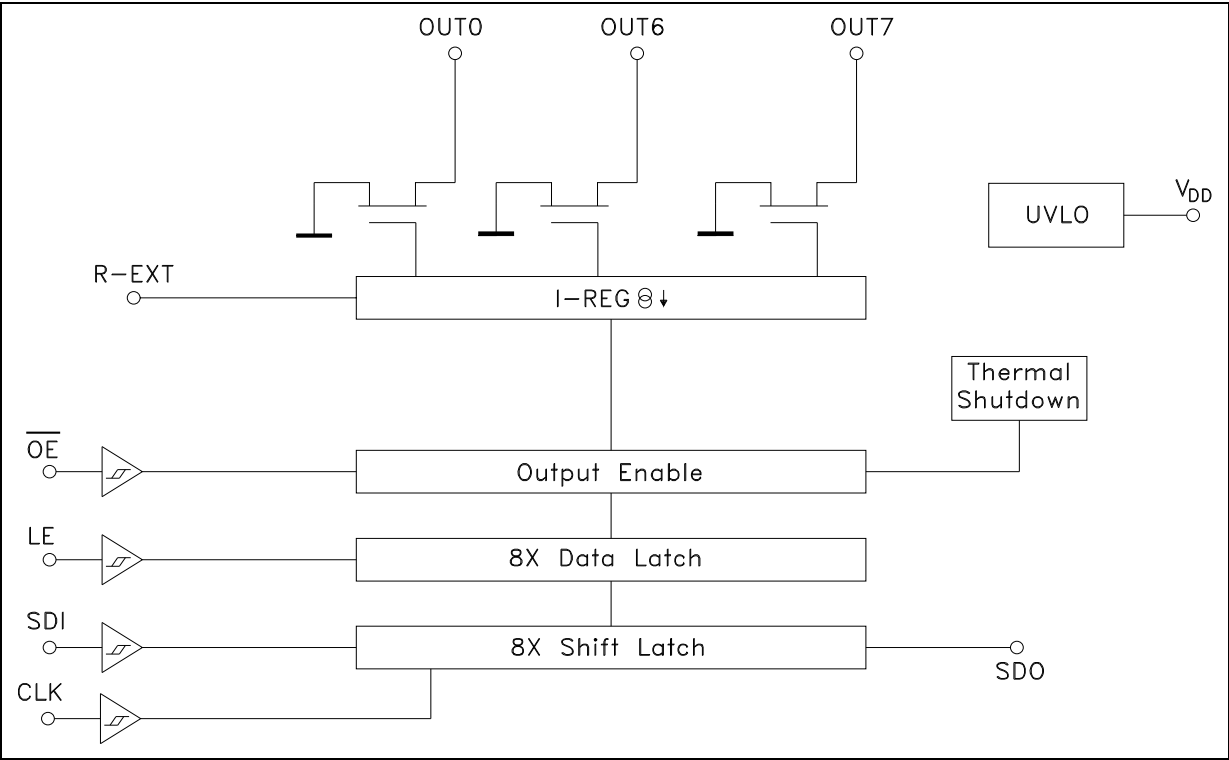

## 3 Maximum rating

Stressing the device above the rating listed in the “absolute maximum ratings” table may cause permanent damage to the device. these are stress ratings only and operation of the device at these or any other conditions above those indicated in the operating sections of this specification is not implied. Exposure to absolute maximum rating conditions for extended periods may affect device reliability.

### 3.1 Absolute maximum ratings

**Table 4. Absolute maximum ratings**

Symbol	Parameter	Value	Unit
$V_{DD}$	Supply voltage $I_{GND}$	0 to 7	V
$V_O$	Output voltage	-0.5 to 20	V
$I_O$	Output current	100	mA
$I_{GND}$	GND terminal current	800	mA
$f_{CLK}$	Clock frequency	50	MHz
$T_{OPR}$	Operating temperature range	-40 to +125	°C
$T_{STG}$	Storage temperature range	-55 to +150	°C

### 3.2 Thermal data

**Table 5. Thermal data**

Symbol	Parameter	DIP-16	SO-16	TSSOP16	TSSOP16 <sup>(1)</sup> exposed pad	Unit
$R_{thJA}$	Thermal resistance junction-ambient	90	125	140	37.5	°C/W

1. The exposed-pad should be soldered to the PBC to realize the thermal benefits

### 3.3 Recommended operating conditions

Table 6. Recommended operating conditions

Symbol	Parameter	Test conditions	Min	Typ	Max	Unit
$V_{DD}$	Supply voltage		3.0		5.5	V
$V_O$	Output voltage				20	V
$I_O$	Output current	OUTn	5		100	mA
$I_{OH}$	Output current	SERIAL-OUT			+1	mA
$I_{OL}$	Output current	SERIAL-OUT			-1	mA
$V_{IH}$	Input voltage		$0.7 V_{DD}$		$V_{DD}+0.3$	V
$V_{IL}$	Input voltage		-0.3		$0.3 V_{DD}$	V
$t_{wLAT}$	LE pulse width	$V_{DD} = 3.0 \text{ to } 5.0 \text{ V}$	20			ns
$t_{wCLK}$	CLK pulse width		20			ns
$t_{wEN}$	$\overline{OE}$ pulse width		200			ns
$t_{SETUP(D)}$	Setup time for DATA		7			ns
$t_{HOLD(D)}$	Hold time for DATA		4			ns
$t_{SETUP(L)}$	Setup time for LATCH		15			ns
$f_{CLK}$	Clock frequency	Cascade operation <sup>(1)</sup>			30	MHz

1. In order to achieve high cascade data transfer, please consider  $t_r/t_f$  timings carefully.

## 4 Electrical characteristics

$V_{DD} = 3.3 \text{ V to } 5 \text{ V}$ ,  $T = 25 \text{ }^\circ\text{C}$ , unless otherwise specified.

**Table 7. Electrical characteristics**

Symbol	Parameter	Test conditions	Min	Typ	Max	Unit
$V_{IH}$	Input voltage high level		$0.7 V_{DD}$		$V_{DD}$	V
$V_{IL}$	Input voltage low level		GND		$0.3V_{DD}$	V
$I_{OH}$	Output leakage current	$V_{OH} = 20 \text{ V}$		0.5	10	$\mu\text{A}$
$V_{OL}$	Output voltage (Serial-OUT)	$I_{OL} = 1 \text{ mA}$		0.03	0.4	V
$V_{OH}$	Output voltage (Serial-OUT)	$I_{OH} = -1 \text{ mA}$	$V_{OH} - V_{DD} = -0.4 \text{ V}$			V
$I_{OL1}$	Output current	$V_O = 0.3 \text{ V}$ , $R_{ext} = 3.9 \text{ k}\Omega$	4.25	5	5.75	mA
$I_{OL2}$		$V_O = 0.3 \text{ V}$ , $R_{ext} = 970 \Omega$	19.4	20	20.6	
$I_{OL3}$		$V_O = 1.3 \text{ V}$ , $R_{ext} = 190 \Omega$	97	100	103	
$\Delta I_{OL1}$	Output current error between bit (All Output ON)	$V_O = 0.3 \text{ V}$ , $R_{EXT} = 3.9 \text{ k}\Omega$		$\pm 5$	$\pm 8$	%
$\Delta I_{OL2}$		$V_O = 0.3 \text{ V}$ , $R_{EXT} = 970 \Omega$		$\pm 1.5$	$\pm 2.75$	
$\Delta I_{OL3}$		$V_O = 1.3 \text{ V}$ , $R_{EXT} = 190 \Omega$		$\pm 1.2$	$\pm 2.5$	
$R_{SIN(up)}$	Pull-up resistor		150	300	600	$\text{K}\Omega$
$R_{SIN(down)}$	Pull-down resistor		100	200	400	$\text{K}\Omega$
$I_{DD(OFF1)}$	Supply current (OFF)	$R_{EXT} = 980$ OUT 0 to 7 = OFF		4	5	mA
$I_{DD(OFF2)}$		$R_{EXT} = 250$ OUT 0 to 7 = OFF		11.2	13.5	
$I_{DD(ON1)}$	Supply current (ON)	$R_{EXT} = 980$ OUT 0 to 7 = ON		4.5	5	
$I_{DD(ON2)}$		$R_{EXT} = 250$ OUT 0 to 7 = ON		11.7	13.5	
Thermal	Thermal protection <sup>(1)</sup>			170		$^\circ\text{C}$

1. Guaranteed by design (not tested)  
The thermal protection switches OFF only the outputs

## 5 Switching characteristics

$V_{DD} = 5\text{ V}$ ,  $T = 25\text{ }^{\circ}\text{C}$ , unless otherwise specified.

**Table 8. Switching characteristics**

Symbol	Parameter	Test conditions		Min	Typ	Max	Unit	
$t_{PLH1}$	Propagation delay time, CLK-OUTn, LE = H, OE = L	$V_{DD} = 3.3\text{ V}$ $V_{IL} = \text{GND}$ $I_O = 20\text{ mA}$ $R_{EXT} = 1\text{ K}\Omega$	$V_{IH} = V_{DD}$ $C_L = 10\text{ pF}$ $V_L = 3.0\text{ V}$ $R_L = 60\text{ }\Omega$	$V_{DD} = 3.3\text{ V}$		35	50	ns
				$V_{DD} = 5\text{ V}$		18	28	
$t_{PLH2}$	Propagation delay time, LE -OUTn, OE = L			$V_{DD} = 3.3\text{ V}$		48	74	ns
				$V_{DD} = 5\text{ V}$		30	50	
$t_{PLH3}$	Propagation delay time, OE -OUTn, LE = H			$V_{DD} = 3.3\text{ V}$		55	82	ns
				$V_{DD} = 5\text{ V}$		37	58	
$t_{PLH}$	Propagation delay time, CLK-SDO			$V_{DD} = 3.3\text{ V}$		21	28	ns
				$V_{DD} = 5\text{ V}$		17	22	
$t_{PHL1}$	Propagation delay time, CLK-OUTn, LE = H, OE = L			$V_{DD} = 3.3\text{ V}$		11	17	ns
				$V_{DD} = 5\text{ V}$		7	11	
$t_{PHL2}$	Propagation delay time, LE -OUTn, OE = L	$V_{DD} = 3.3\text{ V}$		24	40	ns		
		$V_{DD} = 5\text{ V}$		21	31			
$t_{PHL3}$	Propagation delay time, OE -OUTn, LE = H	$V_{DD} = 3.3\text{ V}$		20	35	ns		
		$V_{DD} = 5\text{ V}$		18	28			
$t_{PHL}$	Propagation delay time, CLK-SDO	$V_{DD} = 3.3\text{ V}$		24	32	ns		
		$V_{DD} = 5\text{ V}$		19	25			
$t_{ON}$	Output fall time 10~90% of voltage waveform	$V_{DD} = 3.3\text{ V}$		26	40	ns		
		$V_{DD} = 5\text{ V}$		11	17			
$t_{OFF}$	Output rise time 90~10% of voltage waveform	$V_{DD} = 3.3\text{ V}$		5	10	ns		
		$V_{DD} = 5\text{ V}$		4	8			
$t_r$	CLK rise time <sup>(1)</sup>					5000	ns	
$t_f$	CLK fall time <sup>(1)</sup>					5000	ns	

1. In order to achieve high cascade data transfer, please consider  $t_r/t_f$  timings carefully.



## 6 Equivalent circuit and outputs

Figure 3.  $\overline{OE}$  terminal

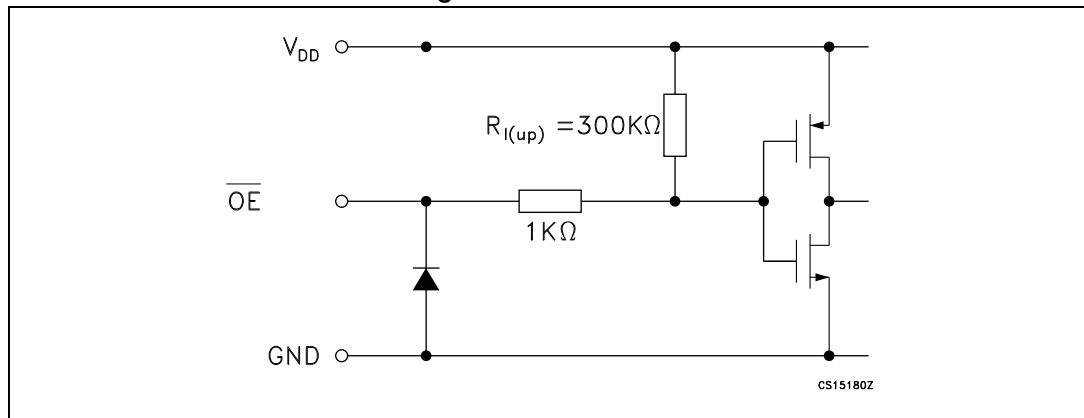

Figure 4. LE terminal

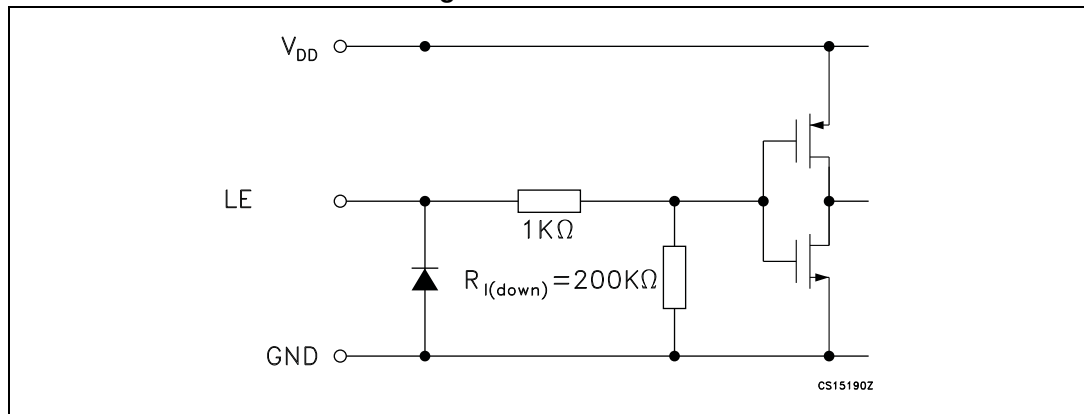

Figure 5. CLK, SDI terminal

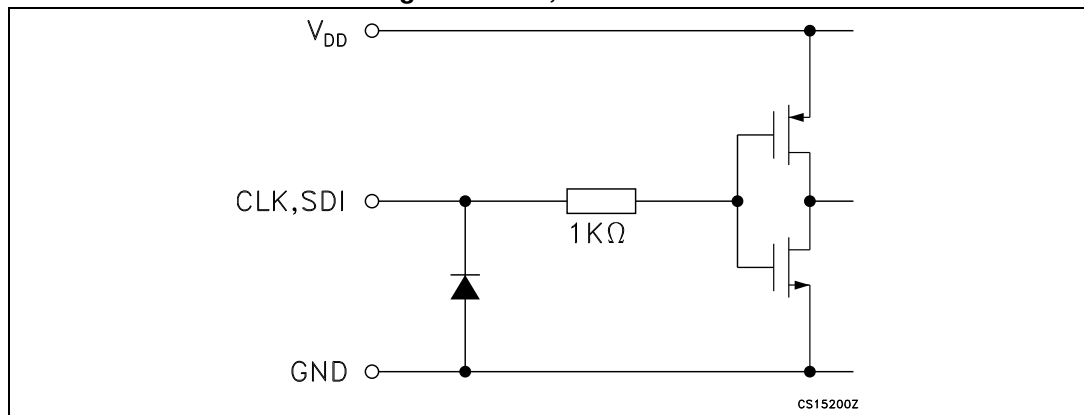
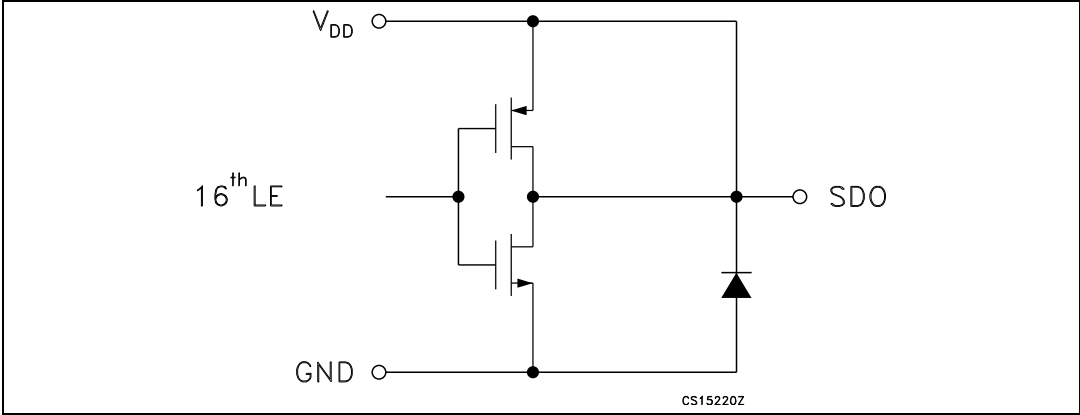

Figure 6. SDO terminal



## 7 Truth table and timing diagram

### 7.1 Truth table

Table 9. Truth table

Clock	$\overline{LE}$	$\overline{OE}$	SDI	$\overline{OUT0}$ ..... $\overline{OUT0}$ ..... $\overline{OUT7}$	SDO
	H	L	Dn	Dn ..... Dn -5 ..... Dn -7	Dn -7
	L	L	Dn + 1	No change	Dn -7
	H	L	Dn + 2	$\overline{Dn +2}$ ..... $\overline{Dn -3}$ ..... $\overline{Dn -5}$	Dn -5
	X	L	Dn + 3	$\overline{Dn +2}$ ..... $\overline{Dn -3}$ ..... $\overline{Dn -5}$	Dn -5
	X	H	Dn + 3	OFF	Dn -5

Note:  $OUT0$  to  $OUT7$  = ON when  $Dn = H$ ;  $OUT0$  to  $OUT7$  = OFF when  $Dn = L$ .

### 7.2 Timing diagram

Figure 7. Timing diagram

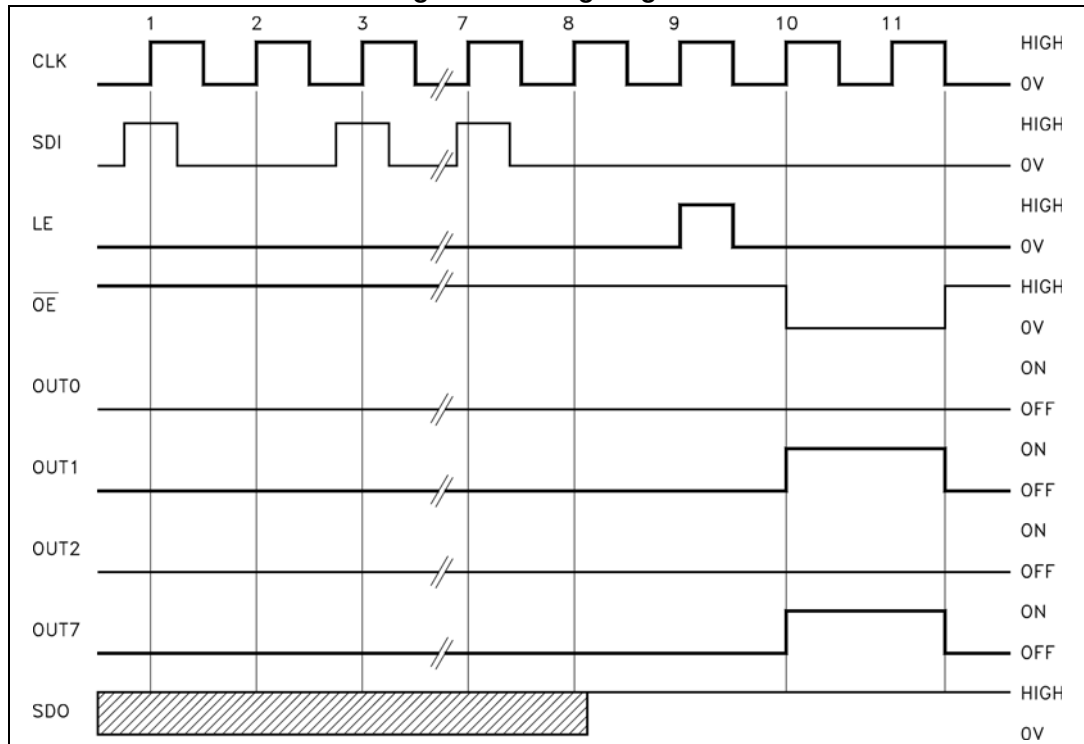

Figure 8. Clock, serial-in, serial-out

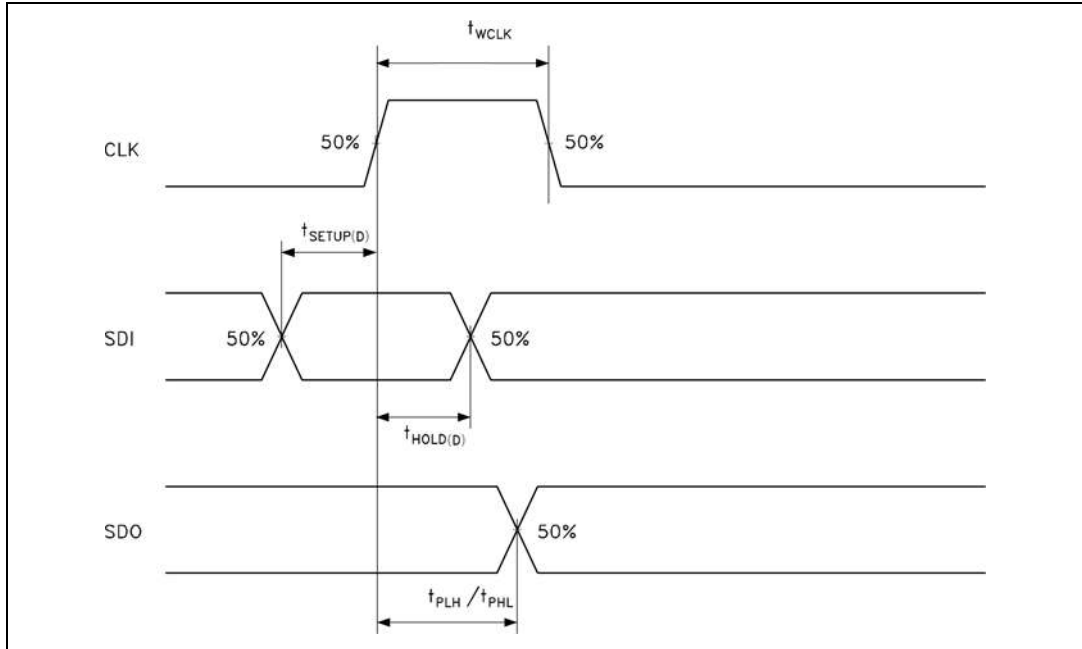

Figure 9. Clock, serial-in, latch, enable, outputs

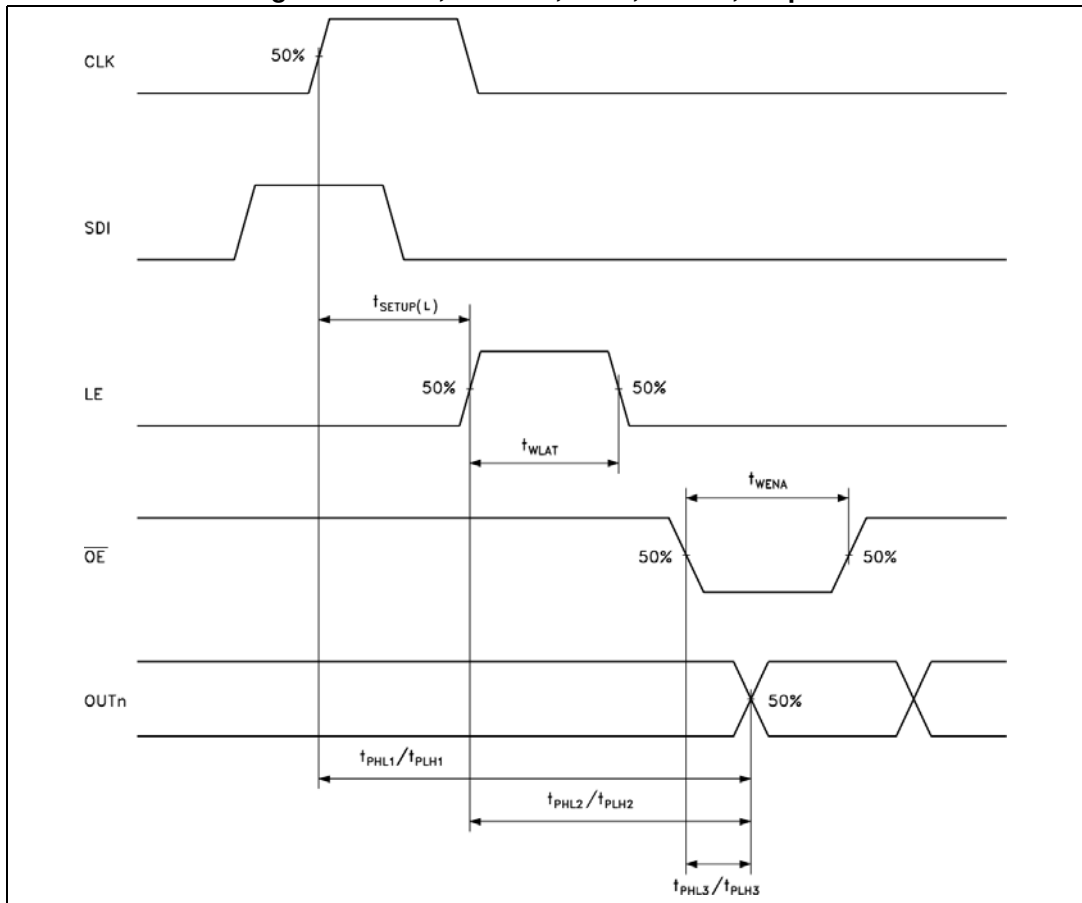
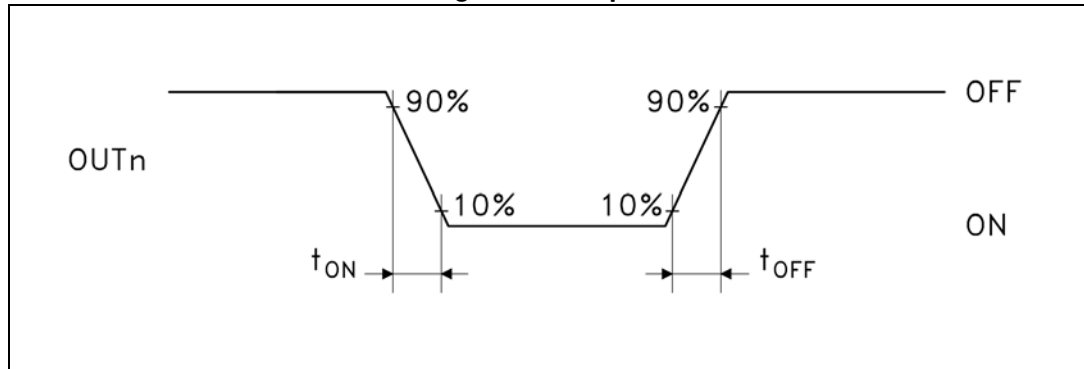

Figure 10. Outputs



## 8 Typical characteristics

Figure 11. Output current- $R_{EXT}$  resistor

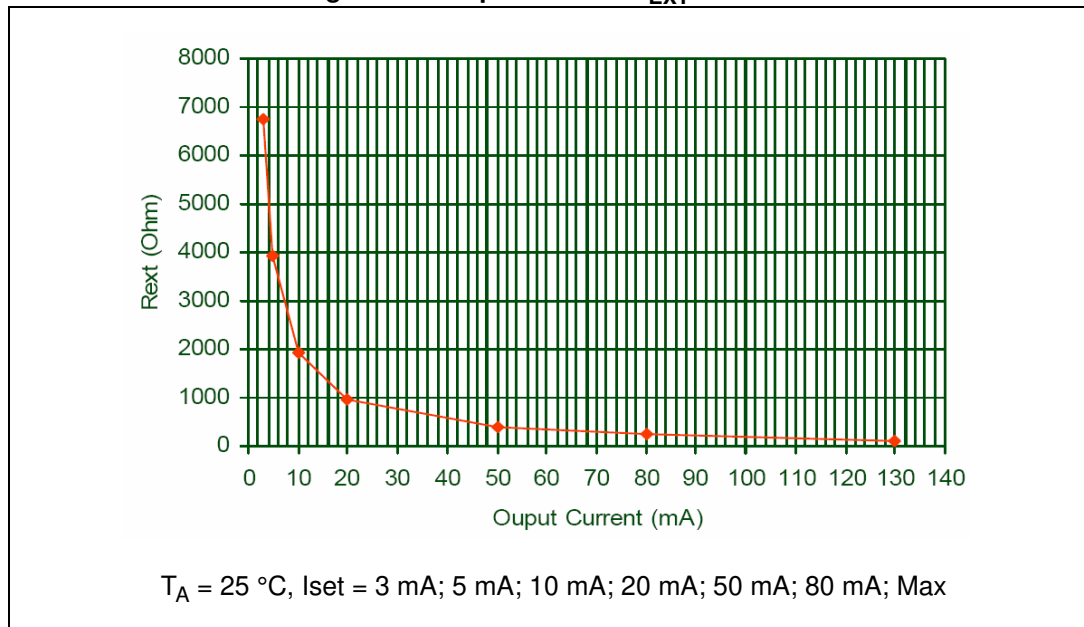

Table 10. Output current- $R_{EXT}$  resistor

Output current (mA)	3	5	10	20	50	80	130
$R_{ext}$ ( $\Omega$ )	6740	3930	1913	963	386	241	124

Note: Maximum output current capabilities setting was 130 mA applying an  $R_{ext} = 124\ \Omega$ .

Figure 12. I<sub>SET</sub> vs. drop out voltage (V<sub>DROP</sub>)

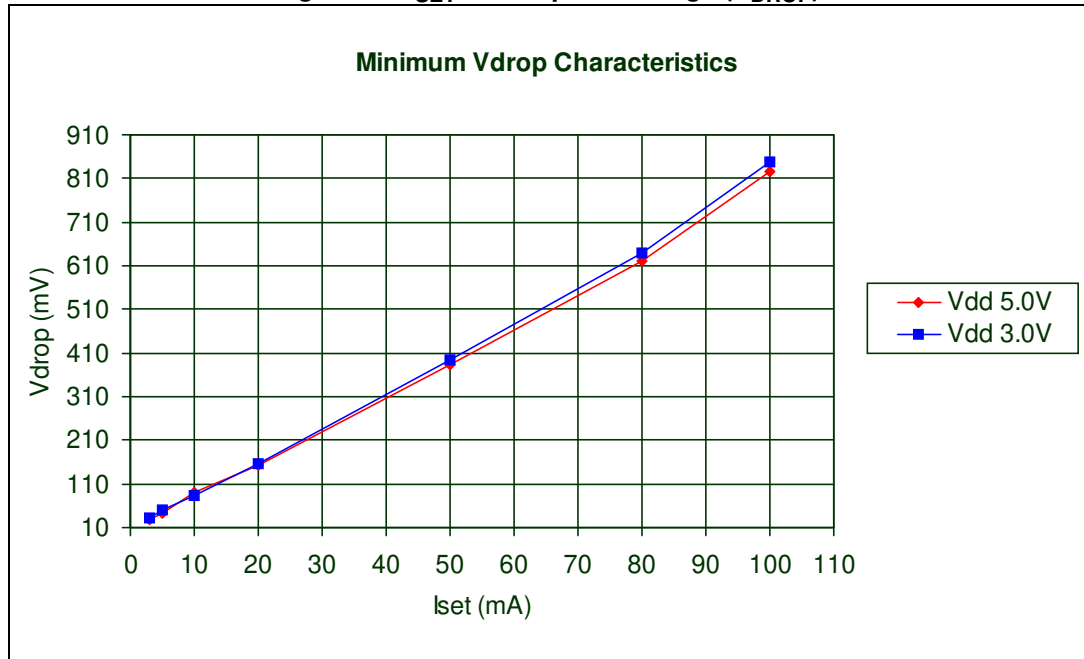
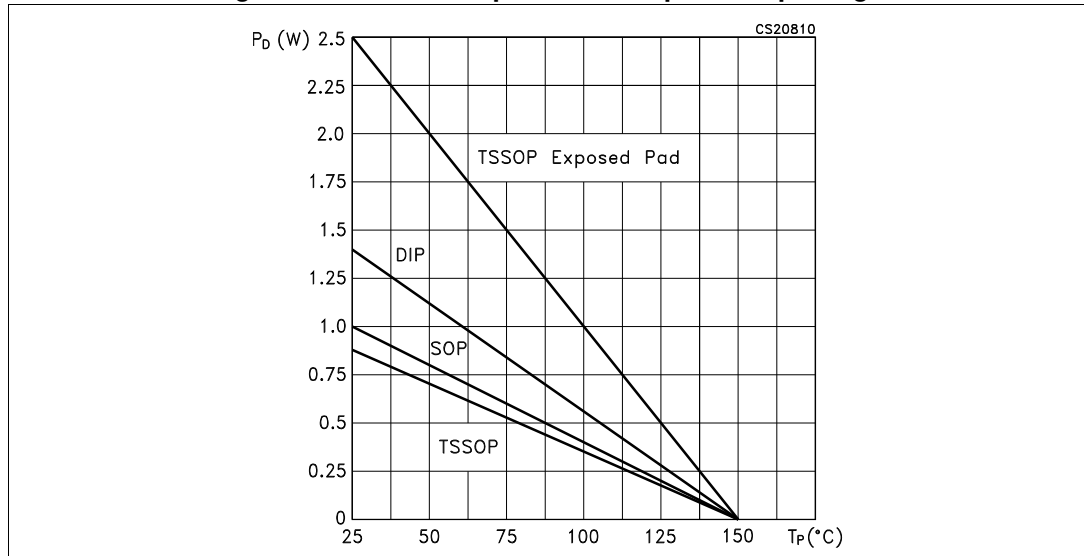

Table 11. I<sub>SET</sub> vs drop out voltage (V<sub>DROP</sub>)

Vdd (V)	Iset (mA)	Rext (Ω)	Vdrop min (mV)	Vdrop max (mV)	Vdrop AVG (mV)
3	3	6470	30.6	31.2	30.93
	5	3930	46.5	52.9	48.63
	10	1910	80.9	100	82.26
	20	963	150	161	157
	50	386	392	396	394.3
	80	241	636	646	640.3
	100	192	846	850	848
5	3	6470	25.6	29	26.96
	5	3930	40.8	41.7	41.16
	10	1910	80.1	105	89.2
	20	963	153	154	154
	50	386	379	386	382
	80	241	618	626	621
	100	192	825	830	827

**Figure 13. Power dissipation vs temperature package**



Note: The exposed-pad should be soldered to the PBC to realize the thermal benefits.

**Figure 14. Current precision between outputs vs output current**

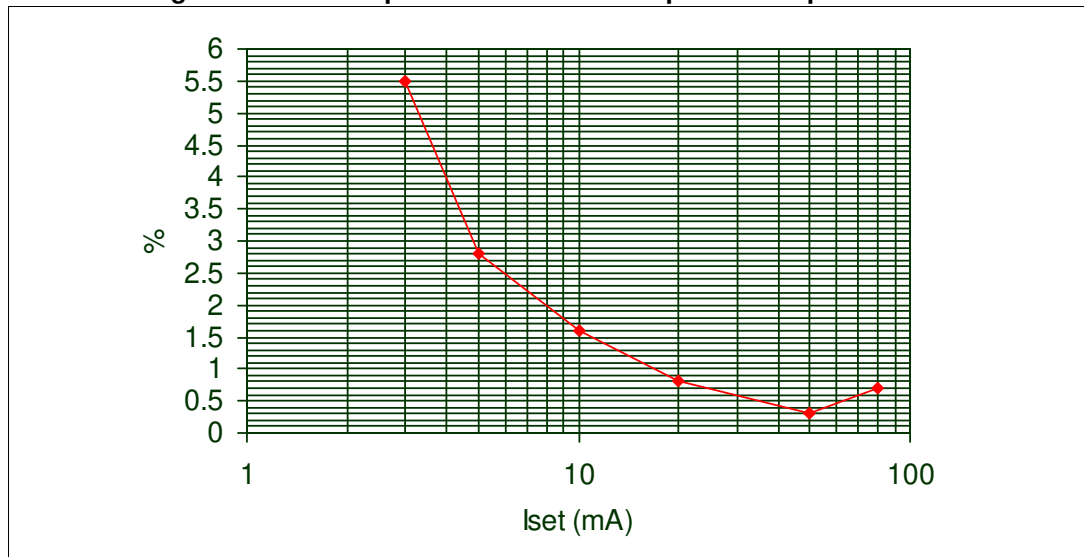



# 9 Test circuit

Figure 15. DC characteristics

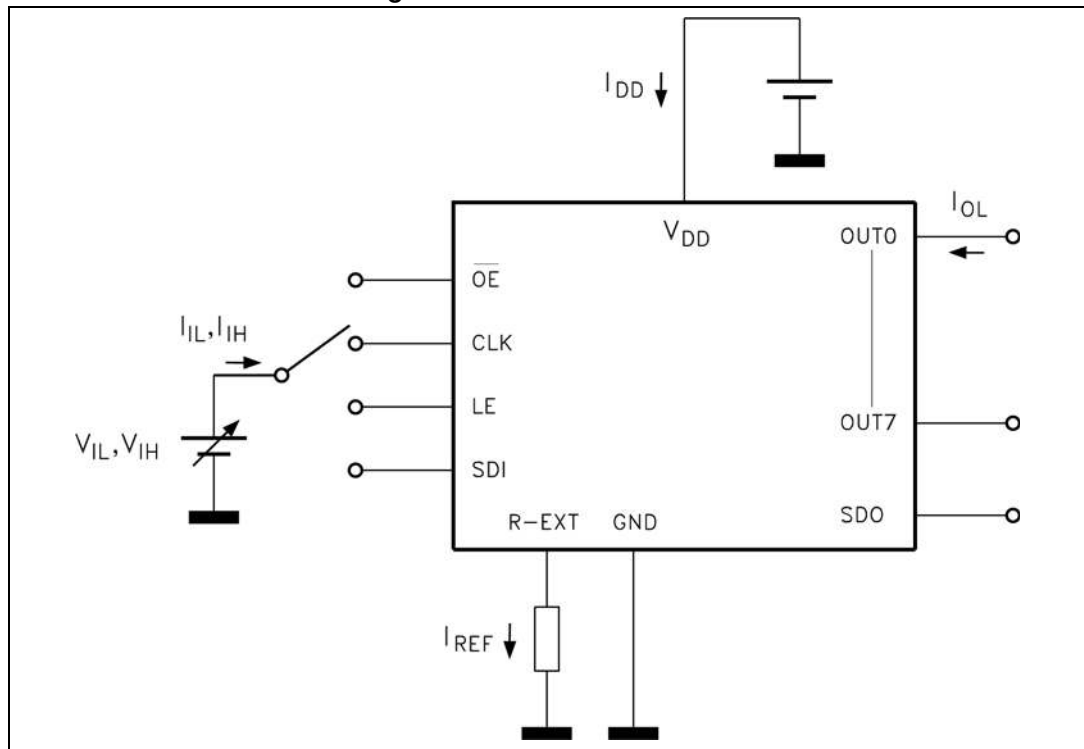
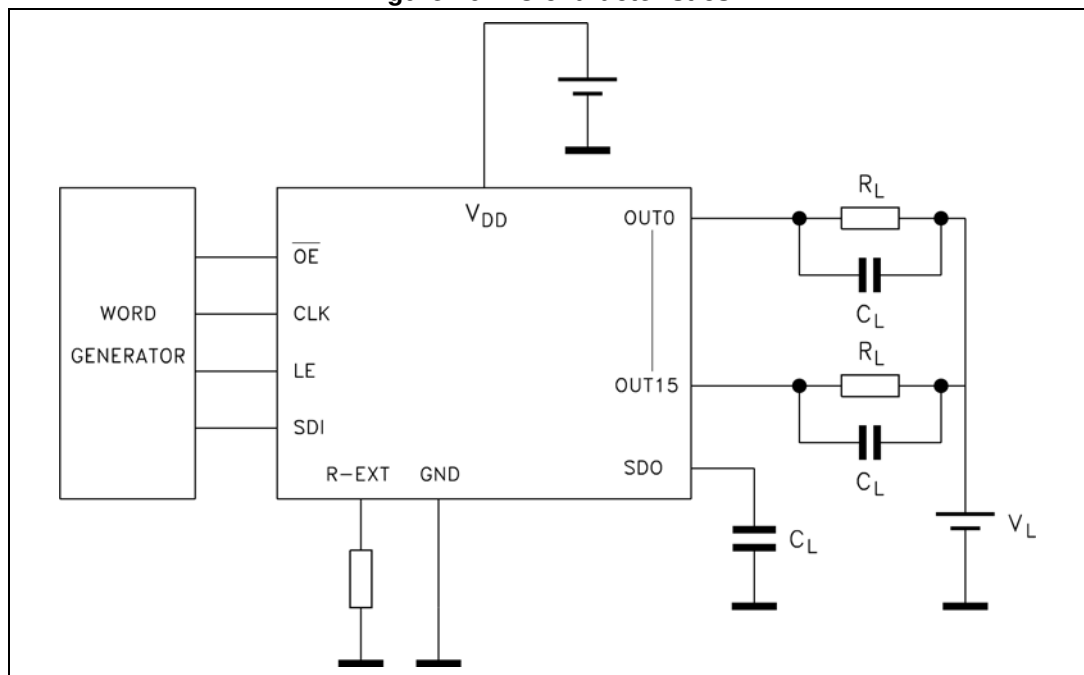

Figure 16. AC characteristics



## 10 Package mechanical data

In order to meet environmental requirements, ST offers these devices in different grades of ECOPACK<sup>®</sup> packages, depending on their level of environmental compliance. ECOPACK<sup>®</sup> specifications, grade definitions and product status are available at: [www.st.com](http://www.st.com). ECOPACK<sup>®</sup> is an ST trademark.

Table 12. DIP-16 mechanical data

Dim.	mm		
	Min.	Typ.	Max.
a1	0.51		
B	0.77		1.65
b		0.5	
b1		0.25	
D			20
E		8.5	
e		2.54	
e3		17.78	
F			7.1
I			5.1
L		3.3	
Z			1.27

Figure 17. DIP-16 drawing

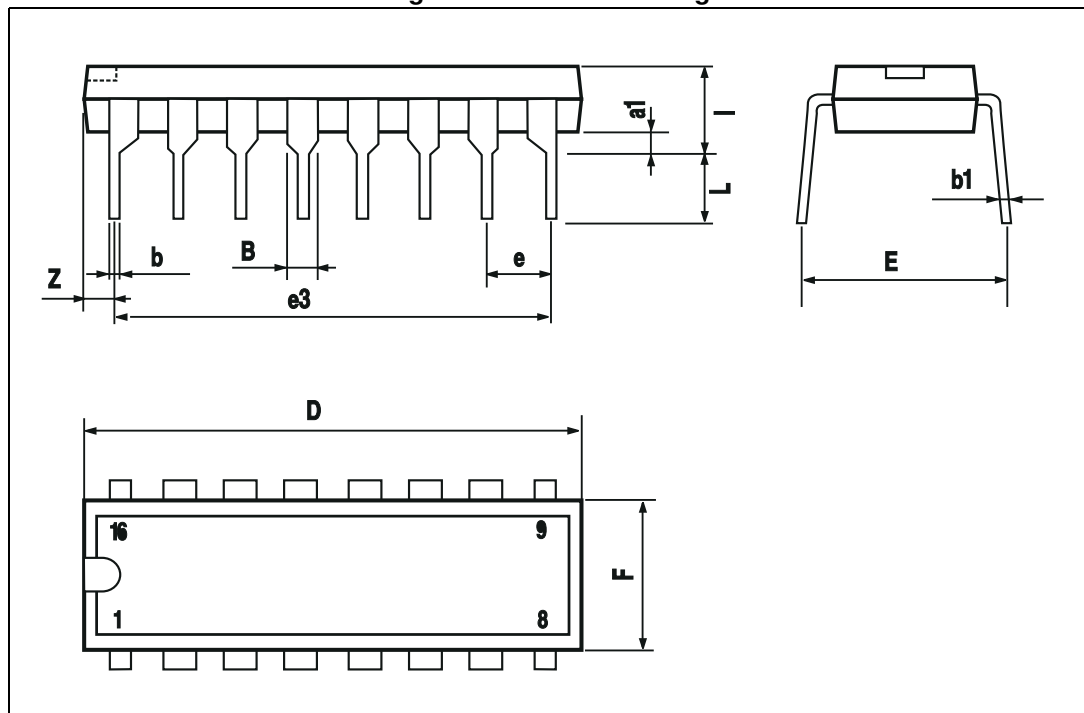

Table 13. TSSOP16 exposed pad mechanical data

Dim.	mm		
	Min.	Typ.	Max.
A			1.20
A1			0.15
A2	0.80	1.00	1.05
b	0.19		0.30
c	0.09		0.20
D	4.90	5.00	5.10
D1		3.00	
E	6.20	6.40	6.60
E1	4.30	4.40	4.50
E2		3.00	
e		0.65	
L	0.45	0.60	0.75
L1		1.00	
k	0.00		8.00
aaa			0.10

Figure 18. TSSOP16 exposed pad drawing

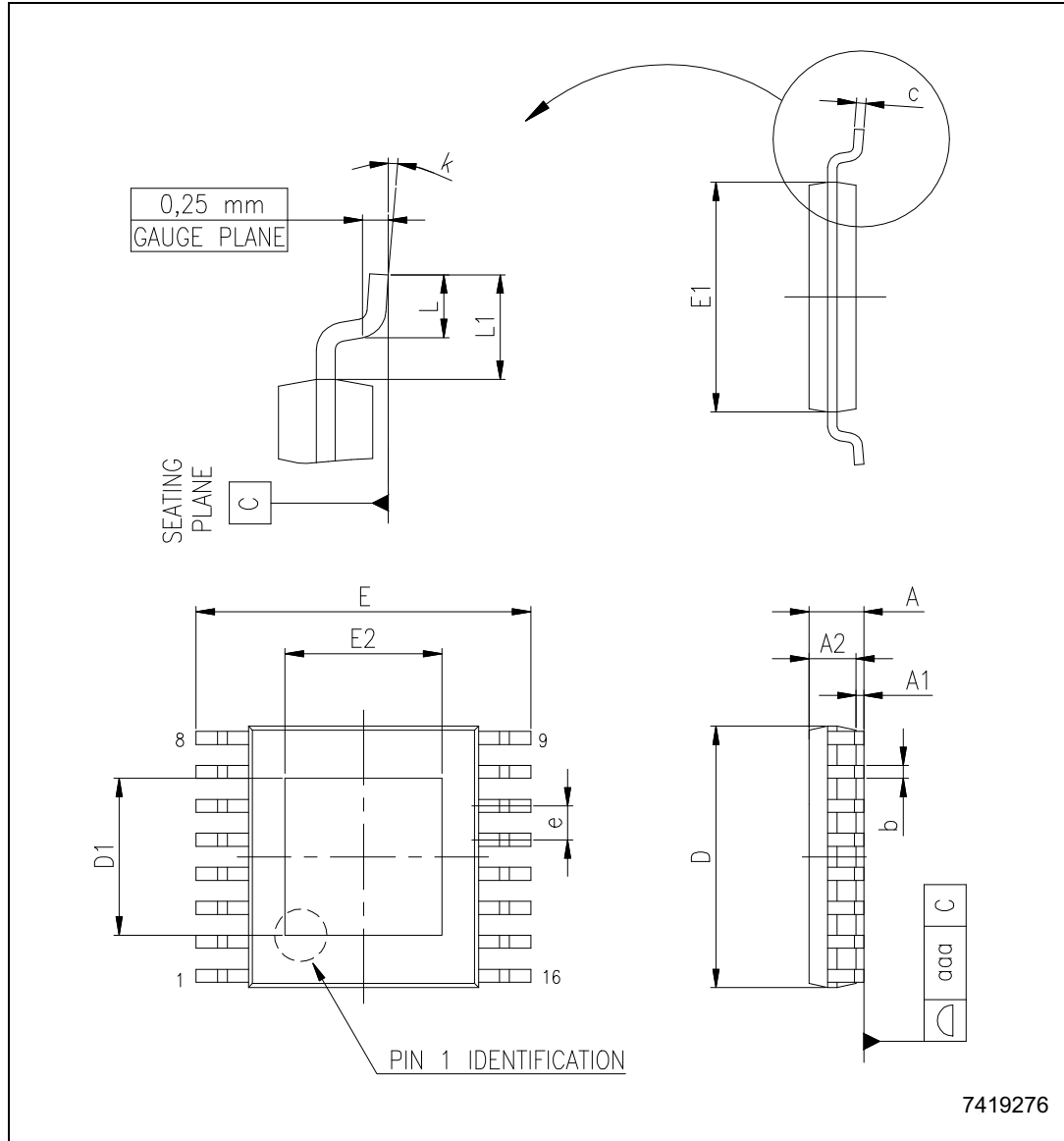

Table 14. TSSOP16 mechanical data

Dim.	mm		
	Min.	Typ.	Max.
A			1.20
A1	0.05		0.15
A2	0.80	1.00	1.05
b	0.19		0.30
c	0.09		0.20
D	4.90	5.00	5.10
E	6.20	6.40	6.60
E1	4.30	4.40	4.50
e		0.65	
L	0.45	0.60	0.75
L1		1.00	
k	0		8
aaa			0.10

Figure 19. TSSOP16 mechanical drawing

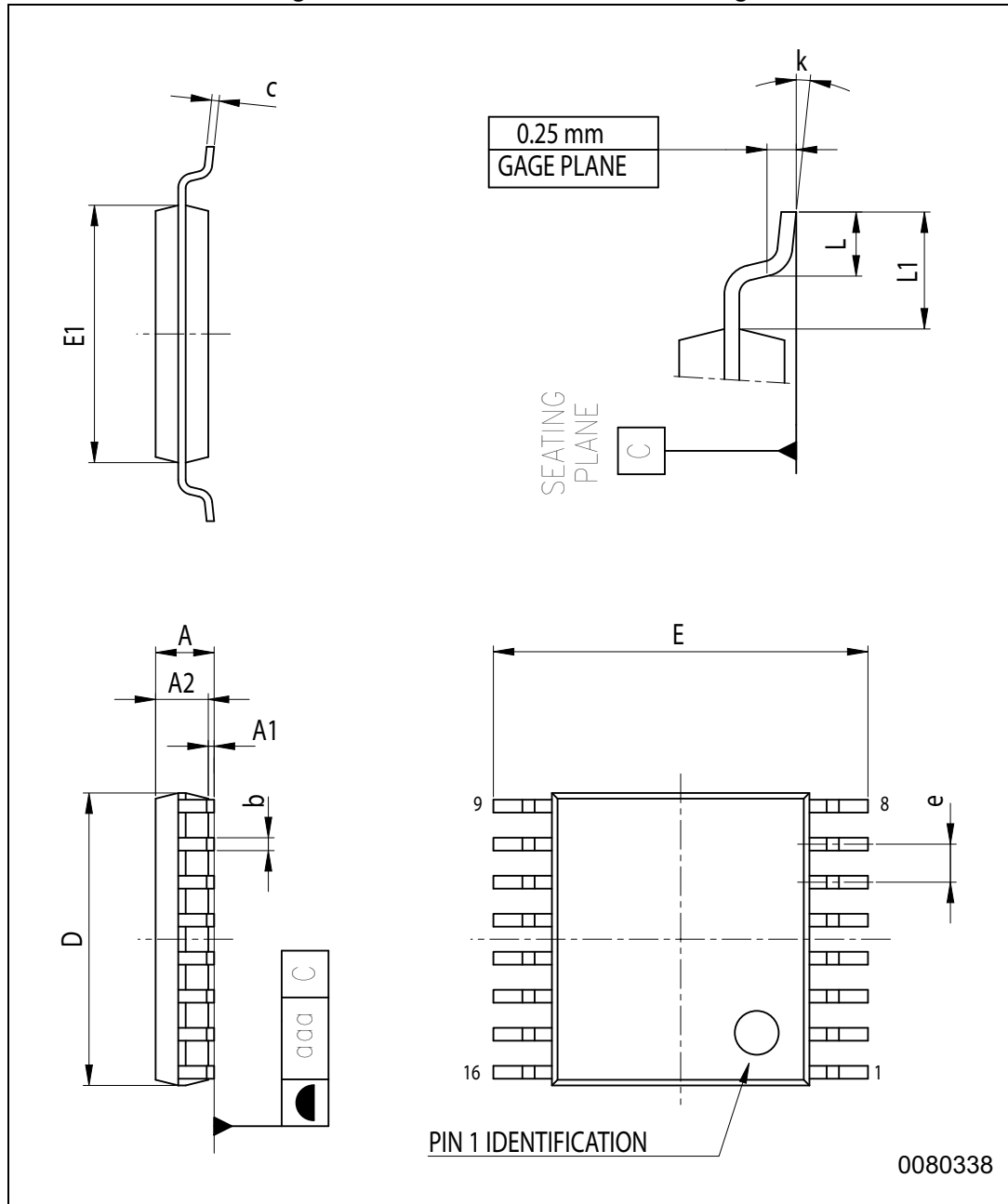
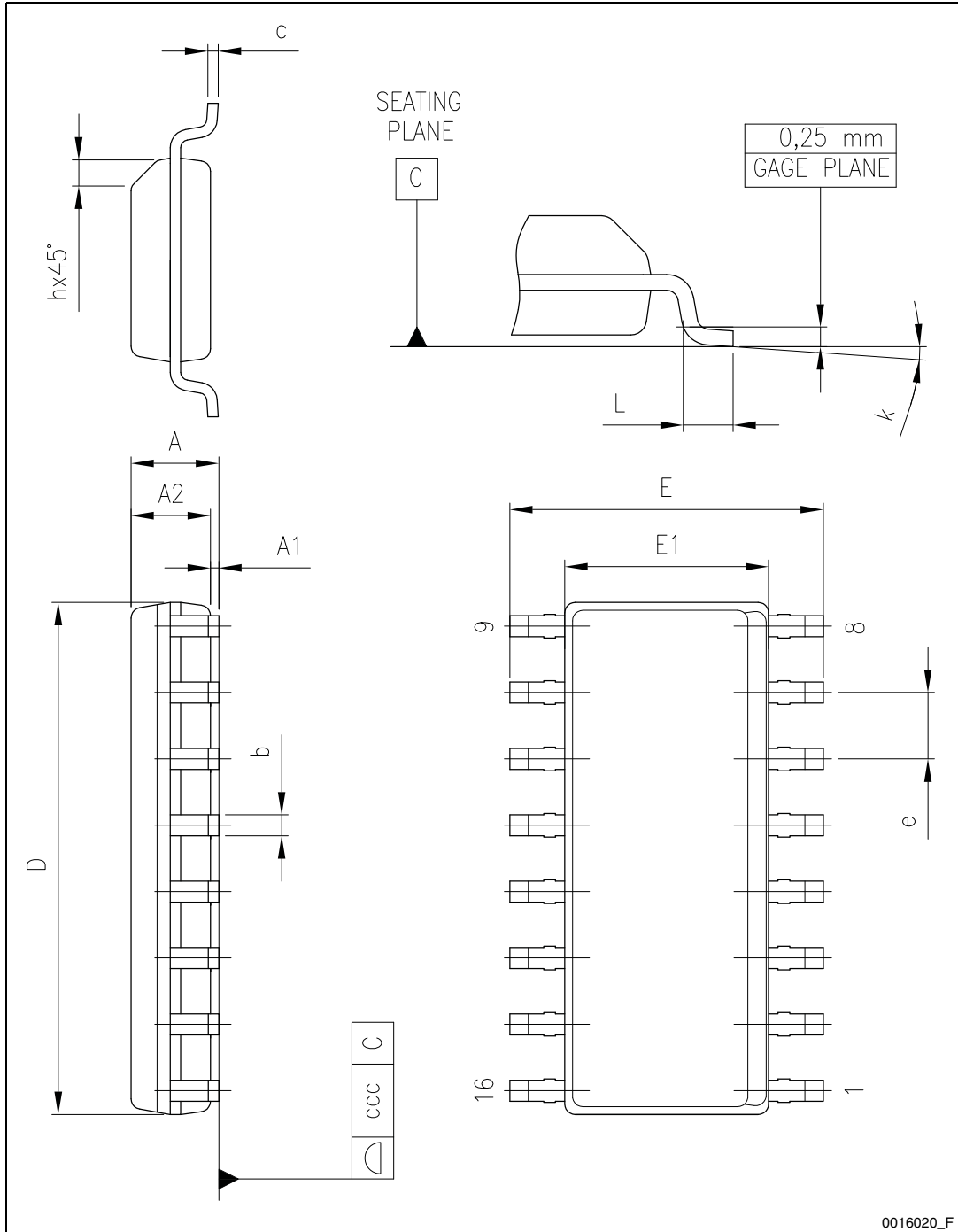

Table 15. SO-16 dimensions

Dim.	mm		
	Min.	Typ.	Max.
A			1.75
A1	0.10		0.25
A2	1.25		
b	0.31		0.51
c	0.17		0.25
D	9.80	9.90	10.00
E	5.80	6.00	6.20
E1	3.80	3.90	4.00
e		1.27	
h	0.25		0.50
L	0.40		1.27
k	0		8°
ccc			0.10

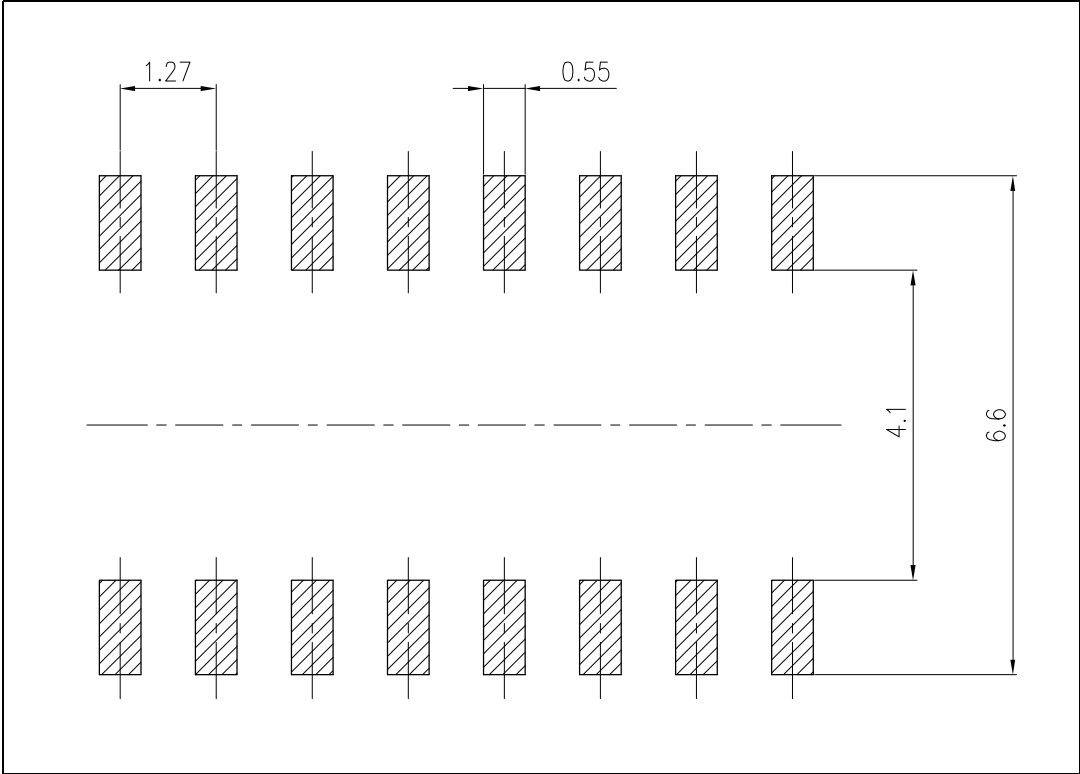

Figure 20. SO-16 package drawing



0016020\_F

Figure 21. SO-16 recommended footprint (dimensions are in mm)



## 11 Packaging mechanical data

Table 16. TSSOP16 exposed pad and TSSOP16 tape and reel mechanical data

Dim.	mm		
	Min.	Typ.	Max.
A			330
C	12.8		13.2
D	20.2		
N	60		
T			22.4
Ao	6.7		6.9
Bo	5.3		5.5
Ko	1.6		1.8
Po	3.9		4.1
P	7.9		8.1

Figure 22. Tape and reel for TSSOP16 exposed pad and TSSOP16

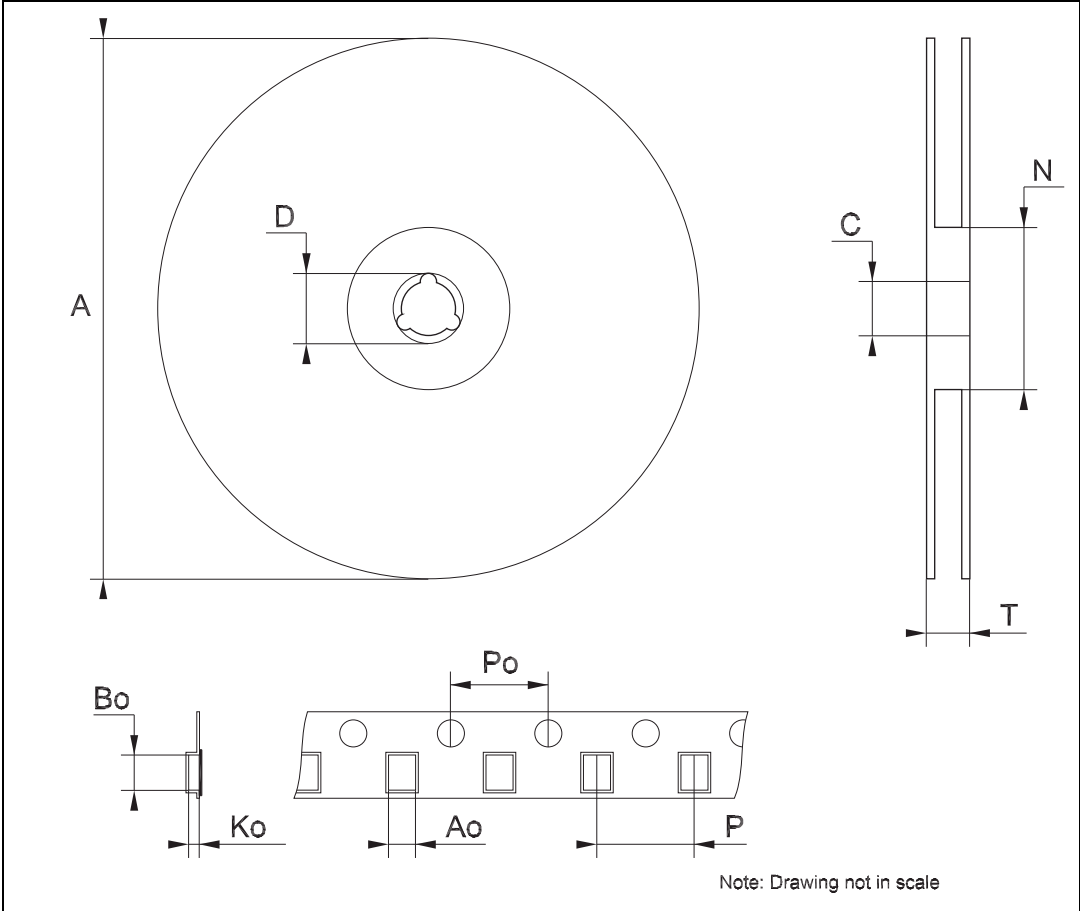

## 12 Revision history

**Table 17. Document revision history**

<b>Date</b>	<b>Revision</b>	<b>Changes</b>
23-May-2007	1	First release
28-Jun-2007	2	Updated Table 7 on page 7
12-Mar-2008	3	Updated Table 8 on page 8 and added Figure 11 and Figure 12 on page 15
07-Aug-2008	4	Updated Section 8: Typical characteristics on page 14
27-Aug-2010	5	Updated Note: on page 3
10-Jul-2013	6	Updated Section 10: Package mechanical data, Figure 3: OE terminal and Figure 4: LE terminal Added Section 11: Packaging mechanical data
28-Jun-2018	7	Updated: Table 14: TSSOP16 mechanical data and Figure 20: TSSOP16 mechanical drawing
29-Aug-2018	8	Updated: <i>Figure 7: Timing diagram, Figure 8: Clock, serial-in, serial-out, Figure 9: Clock, serial-in, latch, enable, outputs, Figure 10: Outputs, Figure 15: DC characteristics and Figure 16: AC characteristics.</i> Minor text changes.

**IMPORTANT NOTICE – PLEASE READ CAREFULLY**

STMicroelectronics NV and its subsidiaries ("ST") reserve the right to make changes, corrections, enhancements, modifications, and improvements to ST products and/or to this document at any time without notice. Purchasers should obtain the latest relevant information on ST products before placing orders. ST products are sold pursuant to ST's terms and conditions of sale in place at the time of order acknowledgement.

Purchasers are solely responsible for the choice, selection, and use of ST products and ST assumes no liability for application assistance or the design of Purchasers' products.

No license, express or implied, to any intellectual property right is granted by ST herein.

Resale of ST products with provisions different from the information set forth herein shall void any warranty granted by ST for such product.

ST and the ST logo are trademarks of ST. All other product or service names are the property of their respective owners.

Information in this document supersedes and replaces information previously supplied in any prior versions of this document.

© 2018 STMicroelectronics – All rights reserved