

APPLICATION SPECIFICATION

COB LED HOLDER APPLICATION SPECIFICATION

1.0 SCOPE

This specification outlines a standard installation and re-work of a Molex LED array holder. These products have two contact points where wires are inserted into releasable wire traps to power the array. Wires can be released for rework or replacement. Additional products such as a directional optic or clear protective cover can be applied during or post installation. This file outlines a re-work or removal of an LED array using the Molex releasable wire-trap.

2.0 PRODUCT DESCRIPTION

This connector consists of a housing with two releasable wire-traps and two wire trap caps or a cover to secure the terminals. Each wire trap can accept 18, 20 and 22 gauge tinned solid core or tinned stranded wire.

2.1 PRODUCT NAME AND PART NUMBER

Material	Material Description
1801500000	ES LED HOLDER W/O COVER
1801500001	ES LED HOLDER WITH COVER
1801900000	HOLDER CITIZEN CL-L340 WITHOUT LENS
1801900001	HOLDER CITIZEN CL-L340 WITH LENS
1802200000	CREE CXA20 LED HOLDER W/O COVER W/O RIBS
1802200001	CREE CXA20 LED HOLDER W COVER W/O RIB
1802600000	HOLDER CITIZEN CL-L330
1803300002	COB LED HOLDER FOR 24 MM X 20 MM RECTANGLE - NYLON
1803300003	COB LED HOLDER FOR 24 MM X 20 MM RECTANGLE ZHAGA COVER
1803300102	COB LED HOLDER FOR 24 MM X 20 MM RECTANGLE - PBT
1803900002	COB LED HOLDER FOR 15 MM X 12 MM RECTANGLE - NYLON
1803900102	COB LED HOLDER FOR 15 MM X 12 MM RECTANGLE - PBT
1805600001	CREE CXA15 WITHOUT PREHOLD - PBT
1805600002	CREE CXA15 WITH PREHOLD - PBT
1805600101	CREE CXA15 WITHOUT PREHOLD - NYLON
1805600102	CREE CXA15 WITH PREHOLD - NYLON
1805800001	COB LED HOLDER FOR 19 MM X 16 MM RECTANGLE - NYLON
1805800004	COB LED HOLDER FOR 19 MM X 16 MM RECTANGLE W/ZHAGA COVER
1805800005	COB LED HOLDER FOR 19 MM X 16 MM RECTANGLE W/ZHAGA COVER LENS ATTACH
1805800101	COB LED HOLDER FOR 19 MM X 16 MM RECTANGLE -PBT
1807200001	CREE CXA25 WITHOUT PREHOLD
1807200002	CREE CXA25 WITH PREHOLD

REVISION: B2	ECR/ECN INFORMATION: EC No: SSL2015-0083 DATE: 17 FEB 2015	TITLE: APPLICATION SPECIFICATION FOR LED ARRAY HOLDERS	SHEET No. 1 of 7
DOCUMENT NUMBER: AS-180328-001	CREATED / REVISED BY: M. COLE	CHECKED BY: Y.ENOMOTO	APPROVED BY: G. MEYER

APPLICATION SPECIFICATION

3.0 REFERENCE DOCUMENTS

Refer to the appropriate file for part numbers and dimensions (SD-180***-000)
 Refer to PS-180***-000 for connector product specification

4.0 PROCEDURE

4.1 GENERAL REQUIREMENTS

4.1.1 Materials needed for installation

- 1) Machine Screws (M3 or 4-40 Screws)
- 2) Torque Wrench (0.2 Nm Min to 0.8 Nm Max Torque)
- 3) Thermal interface material (SIL Pad, phase change pad, or Thermal Grease)
- 4) Power Supply to power LED Array
- 5) Wire Cutter/Stripper
- 6) Straight Pin (Only needed for removal or replacement)

5.0 ASSEMBLY INSTRUCTIONS

5.0.0 - Tap (2) M3 or 4-40 holes in the Heat sink or fixture for the holder screws. See applicable sales drawing for proper hole spacing.

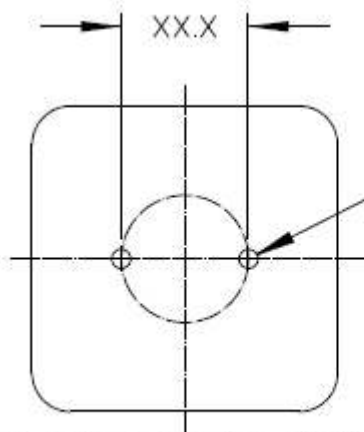

(2) M3 OR 4-40 TAPPED HOLES (2)
 TORQUE: CERAMIC 0,20 N-M MIN TO 0,40 N-M MAX
 ALUMINUM 0,40 N-M MIN TO 0,80 N-M MAX

RECOMMENDED MOUNTING DIMENSIONS (NTS)

REVISION: B2	ECR/ECN INFORMATION: EC No: SSL2015-0083 DATE: 17 FEB 2015	TITLE: APPLICATION SPECIFICATION FOR LED ARRAY HOLDERS	SHEET No. 2 of 7
DOCUMENT NUMBER: AS-180328-001	CREATED / REVISED BY: M. COLE	CHECKED BY: Y.ENOMOTO	APPROVED BY: G. MEYER

APPLICATION SPECIFICATION

5.0.1 – Apply thermal interface material to the back of the LED

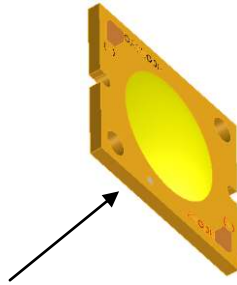

5.0.2 – Apply the M3 or 4-40 screws with 0.2 (MIN) to 0.8 Nm (MAX) of force on each screw
TORQUE: CERAMIC 0.20 N-M MIN TO 0.40 N-M MAX;
ALUMINUM 0.40 N-M MINTO 0.80 N-M MAX

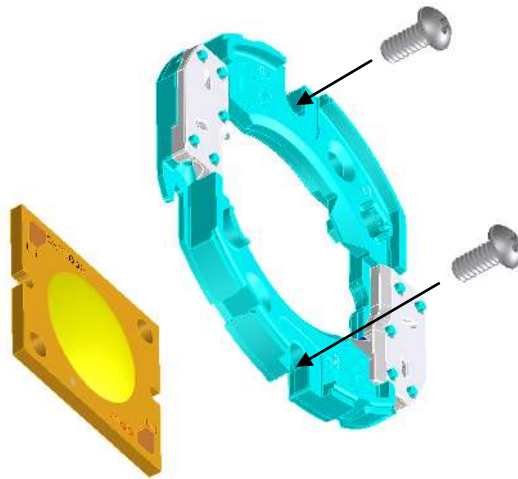

5.0.3 – Insert the black wire into the indicated anode (-) wire trap slot

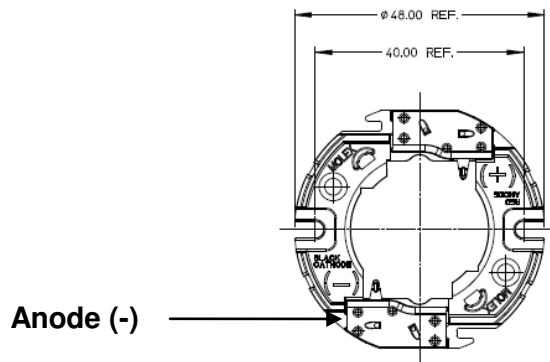

REVISION: B2	ECR/ECN INFORMATION: EC No: SSL2015-0083 DATE: 17 FEB 2015	TITLE: APPLICATION SPECIFICATION FOR LED ARRAY HOLDERS	SHEET No. 3 of 7
DOCUMENT NUMBER: AS-180328-001	CREATED / REVISED BY: M. COLE	CHECKED BY: Y.ENOMOTO	APPROVED BY: G. MEYER

APPLICATION SPECIFICATION

5.0.4 – Insert the red wire into the indicate cathode (+) wire trap slot

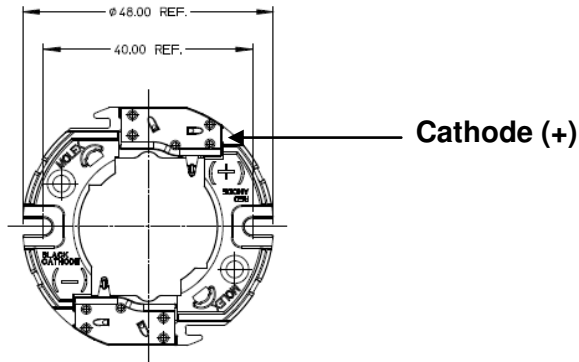

Note: wires can be inserted at either end of the Cathode (+) wire trap

Note: wires can be inserted at either end of the Anode (-) wire trap and should maintain 10mm (+2/-0 mm) strip length

5.0.5 – Bend wires through the slots in the holder (*Only available on select holder designs*)

Note: This step is only required if the wire path holes are directly below the wire slot on the holder

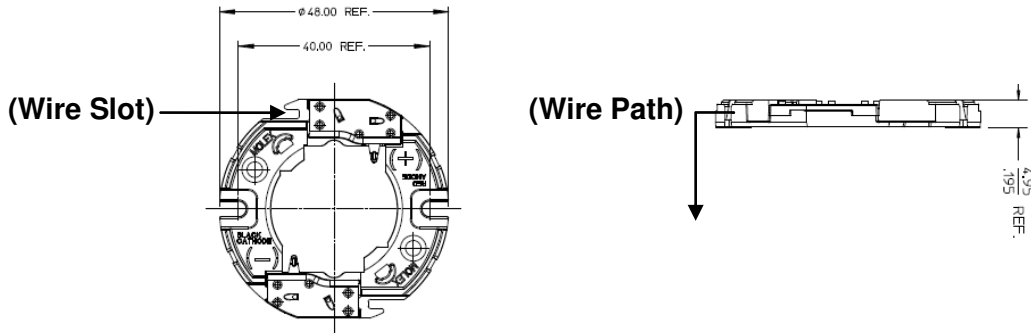

REVISION: B2	ECR/ECN INFORMATION: EC No: SSL2015-0083 DATE: 17 FEB 2015	TITLE: APPLICATION SPECIFICATION FOR LED ARRAY HOLDERS	SHEET No. 4 of 7
DOCUMENT NUMBER: AS-180328-001	CREATED / REVISED BY: M. COLE	CHECKED BY: Y.ENOMOTO	APPROVED BY: G. MEYER

APPLICATION SPECIFICATION

5.0.6 – Thread wires through the two original wire path holes in the heat sink/fixture

Note: Heat sink/Fixture may need to be pre-drilled for wire path

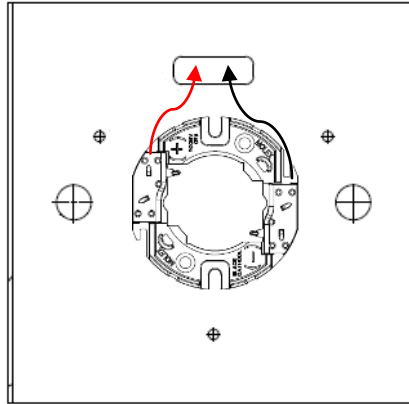

5.0.7 – Pull wires through holes ensuring that the holder is placed and fits flush on the top of the heat sink or with the mounting area on the inside of the fixture

Note: wire strain relief inside fixture recommended prior to attaching power source

5.0.8 – Removal of wire from wire trap

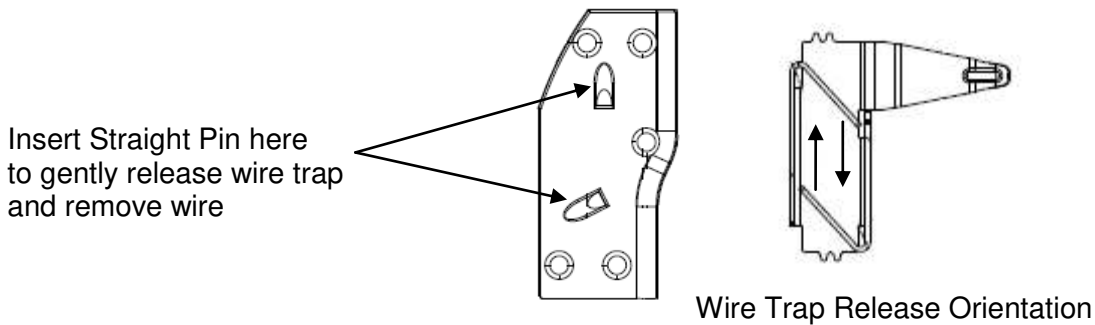

Note: Do not overstress beam when removing, only gentle pressure of 4 Newton or less is required

REVISION: B2	ECR/ECN INFORMATION: EC No: SSL2015-0083 DATE: 17 FEB 2015	TITLE: APPLICATION SPECIFICATION FOR LED ARRAY HOLDERS	SHEET No. 5 of 7
DOCUMENT NUMBER: AS-180328-001	CREATED / REVISED BY: M. COLE	CHECKED BY: Y.ENOMOTO	APPROVED BY: G. MEYER

APPLICATION SPECIFICATION

6.0 THERMAL INTERFACE MATERIAL (TIM) GUIDELINES

6.0.1 Molex holders are designed to be compatible with either thermal grease or TIM pads (typically 0.25mm thick). Note: Customer is responsible for choosing appropriate TIM material or thermal grease.

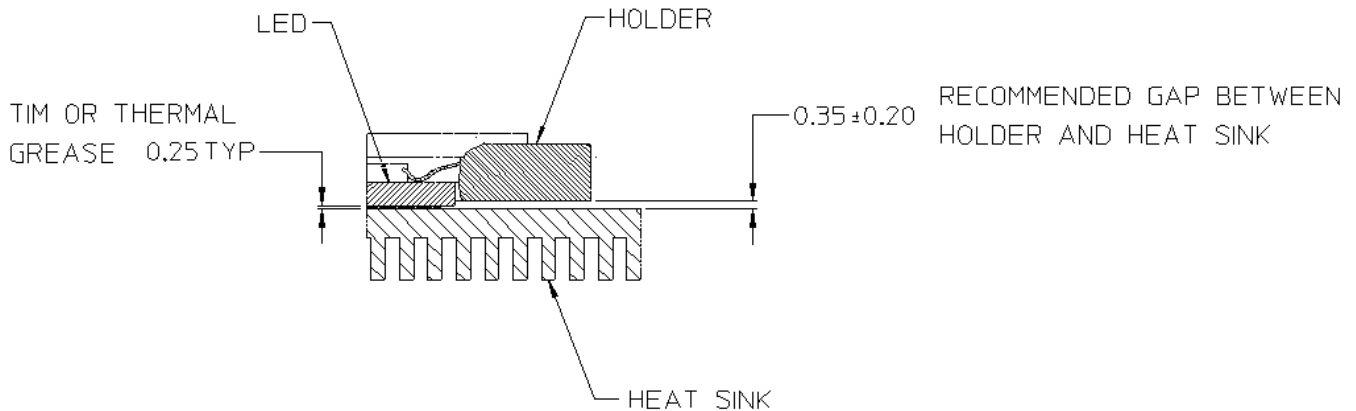

6.0.2 If TIM material exceeds 0.25 mm thickness, the LED holder may tilt excessively when screwed down. It is recommended that the TIM extends to the area below the LED holder as shown below to provide support under the screws.

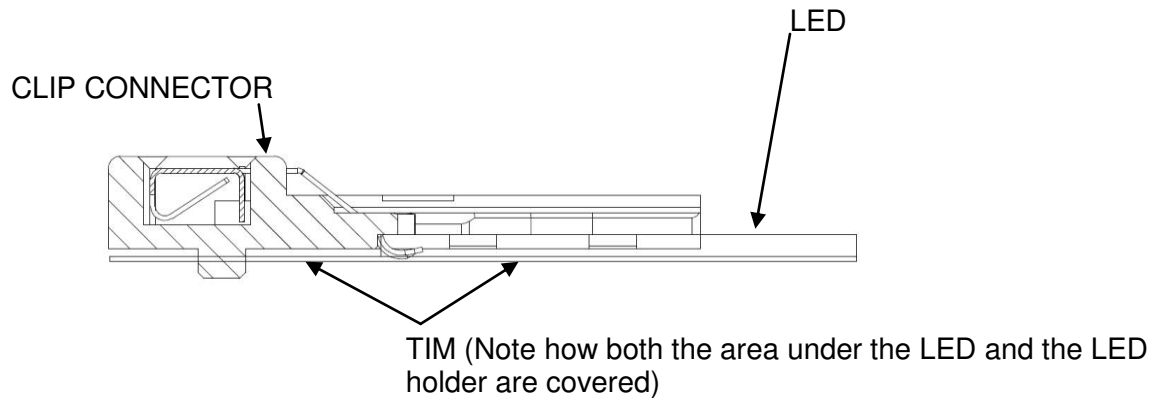

REVISION: B2	ECR/ECN INFORMATION: EC No: SSL2015-0083 DATE: 17 FEB 2015	TITLE: APPLICATION SPECIFICATION FOR LED ARRAY HOLDERS	SHEET No. 6 of 7
DOCUMENT NUMBER: AS-180328-001	CREATED / REVISED BY: M. COLE	CHECKED BY: Y.ENOMOTO	APPROVED BY: G. MEYER

APPLICATION SPECIFICATION

6.0.3 If combined LED and TIM thickness exceeds recommended gap (0.35 ± 0.20), a step or pocket is required in heat sink to provide relief to area below LED/TIM.

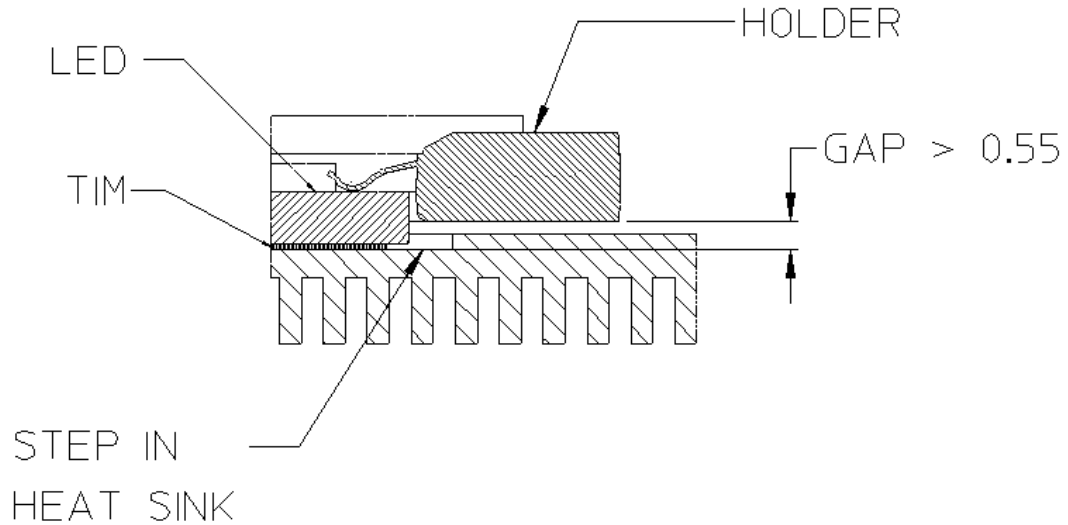

REVISION: B2	ECR/ECN INFORMATION: EC No: SSL2015-0083 DATE: 17 FEB 2015	TITLE: APPLICATION SPECIFICATION FOR LED ARRAY HOLDERS	SHEET No. 7 of 7
DOCUMENT NUMBER: AS-180328-001	CREATED / REVISED BY: M. COLE	CHECKED BY: Y.ENOMOTO	APPROVED BY: G. MEYER