

DO NOT SCALE FROM THIS PRINT

DESIGNED & DIMENSIONED IN MILLIMETERS

MPSC-XX-XX-XX-01-XX-X-RA-XX

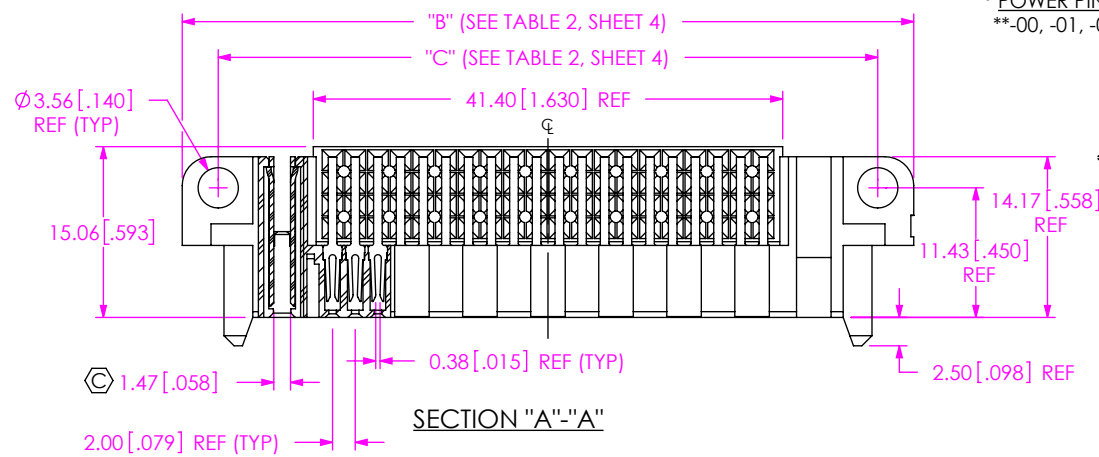

\* POWER PINS (PER END)  
\*\*-00, -01, -02,

\* SIGNAL PINS  
-16: (4 x 4)  
-24: (4 x 6)  
-40: (4X10)  
-80: (4 X 20)

\* POWER PINS (PER END)  
-01, -02, \*\*-03, \*\*-04

LEAD STYLE  
-01

OPTION  
-SD: SCREW DOWN (SEE FIG 1)  
-LC: LOCKING CLIP (SEE FIG 2, SHT 2)  
(-SD OR -LC MUST BE SELECTED)

RIGHT ANGLE

PLATING SPECIFICATION  
-L: SEE TABLE 3, SHEET 4  
-T: SEE TABLE 3, SHEET 4

TAIL LENGTH  
-01: FOR 1.57[.062] THICK PCB  
\*\*\*-02: FOR 2.36[.093] THICK PCB  
-03: FOR 2.36[.093] THICK PCB

\* = SEE TABLE 2 FOR AVAILABLE COMBINATIONS  
\*\* = NOT RELEASED  
\*\*\* = EXISTING CUSTOMERS ONLY

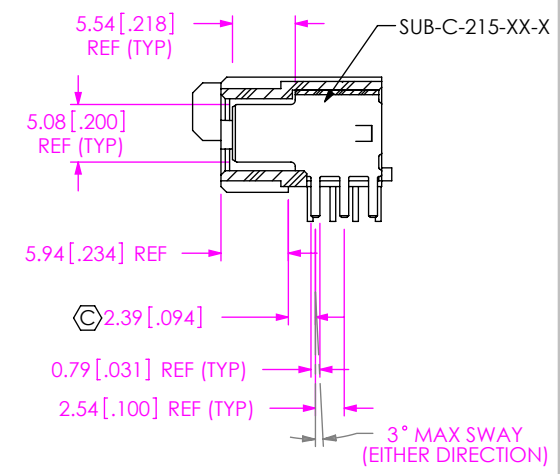
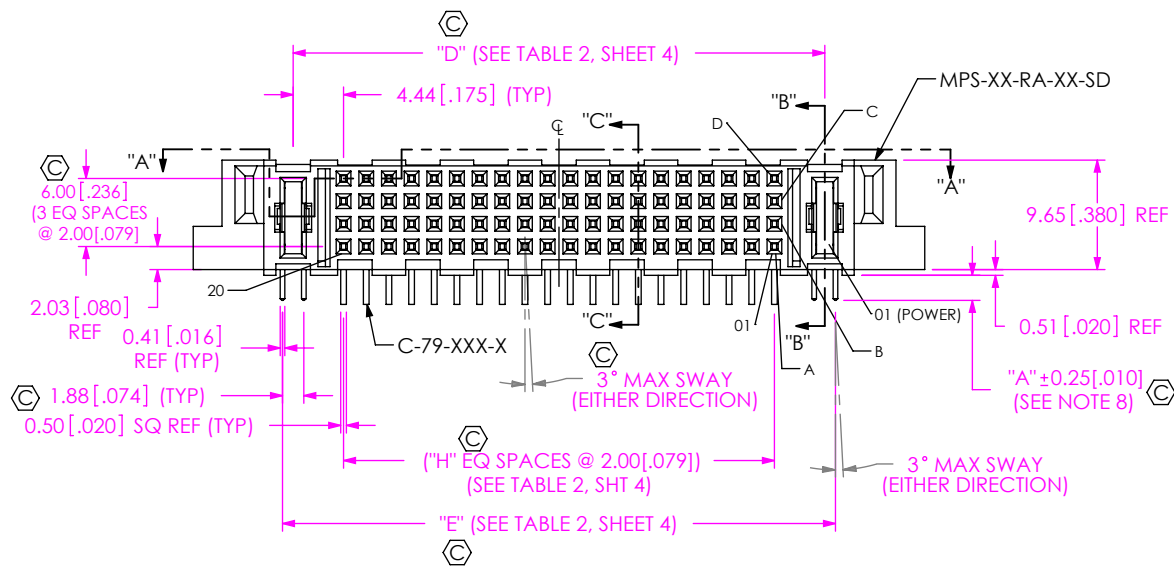

FIG 1  
MPSC-01-80-01-01-01-X-RA-SD SHOWN

PART NUMBER	BODY	SPACER BODY	POWER CONTACT SUB-ASSEMBLY	SIGNAL CONTACT				"A"
				CONTACT 1	CONTACT 2	CONTACT 3	CONTACT 4	
MPSC-XX-XX-XX-01-01-X-RA-XX	MPS-XX-RA-XX-XX	MP-XX-Q	SUB-C-215-01-X	C-79-12-L	C-79-12-L	C-79-23B-L	C-79-23B-L	2.20 [0.087]
MPSC-XX-XX-XX-01-03-X-RA-XX			SUB-C-215-04-X	C-79-12-L	C-79-12-L	C-79-23B-L	C-79-23B-L	3.00 [0.118]

NOTES:

1. Ⓢ REPRESENTS A CRITICAL DIMENSION.
2. MAXIMUM BURR ALLOWANCE: 0.038[.0015]
3. MINIMUM PUSHOUT FORCE: 4.45N[1.0 LB].
4. PARTS TO BE PACKAGED IN TRAYS.
5. BOW ALLOWED AT 0.075MM[.0030]/25.0MM[.98].
6. NOTE DELETED.
7. POSITION ONE MARK ON TRAYS DOES NOT CORRESPOND W/ POSITION 1 LOCATION ON PARTS.
8. THIS DIMENSION APPLIES TO POWER AND SIGNAL PINS.
9. NOTE DELETED.

UNLESS OTHERWISE SPECIFIED, DIMENSIONS ARE IN MILLIMETERS.  
TOLERANCES ARE:  
DECIMALS ANGLES  
.X: ±0.3 [.01] 2°  
.XX: ±0.13 [.005]  
.XXX: ±0.051 [.0020]

PROPRIETARY NOTE  
THIS DOCUMENT CONTAINS CONFIDENTIAL AND PROPRIETARY INFORMATION AND ALL DESIGN, MANUFACTURING, REPRODUCTION, USE, PATENT RIGHTS AND SALES RIGHTS ARE EXPRESSLY RESERVED BY SAMTEC, INC. THIS DOCUMENT SHALL NOT BE DISCLOSED, IN WHOLE OR PART, TO ANY UNAUTHORIZED PERSON OR ENTITY NOR REPRODUCED, TRANSFERRED OR INCORPORATED IN ANY OTHER PROJECT IN ANY MANNER WITHOUT THE EXPRESS WRITTEN CONSENT OF SAMTEC, INC.



520 PARK EAST BLVD, NEW ALBANY, IN 47150  
PHONE: 812-944-6733 FAX: 812-948-5047  
e-Mail info@SAMTEC.com code 55322

MATERIAL: DO NOT SCALE DRAWING SHEET SCALE: 3:2  
INSULATOR: LCP, UL 94 V-0, COLOR: BLACK  
POWER CONTACT: COPPER ALLOY  
SIGNAL CONTACT: PHOS BRONZE

DESCRIPTION:  
RA MINI-POWER W/ SIGNAL SOCKET  
DWG. NO.  
MPSC-XX-XX-XX-01-XX-X-RA-XX  
BY: BRATCHER 2/20/2007 SHEET 1 OF 4

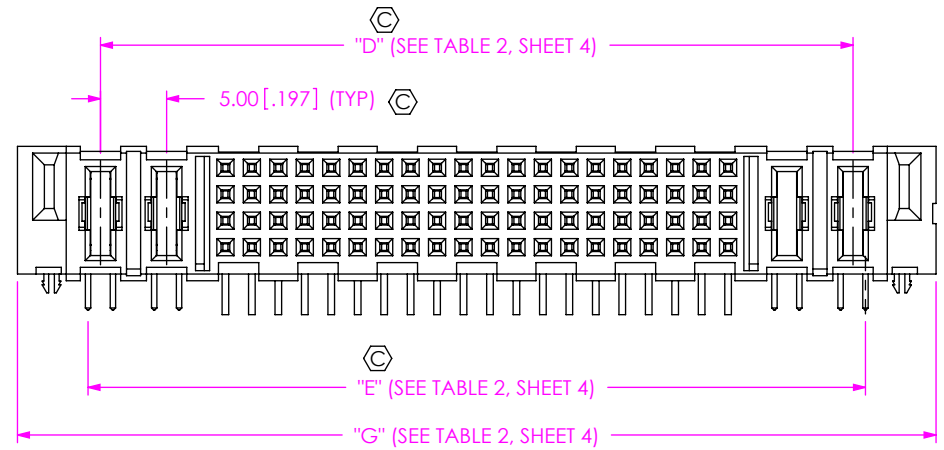
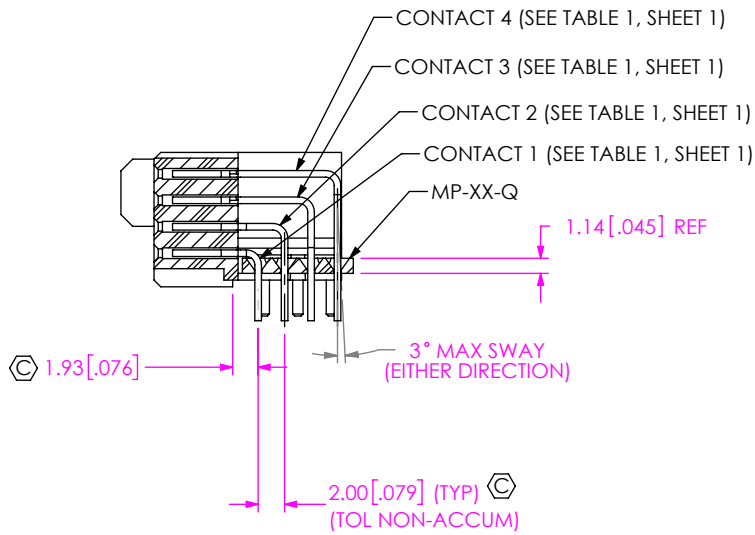

FIG 3  
 MPSC-02-80-02-01-01-X-RA-LC SHOWN  
 (SAME AS FIG 1, UNLESS OTHERWISE STATED)  
 SECTION "C"-"C"

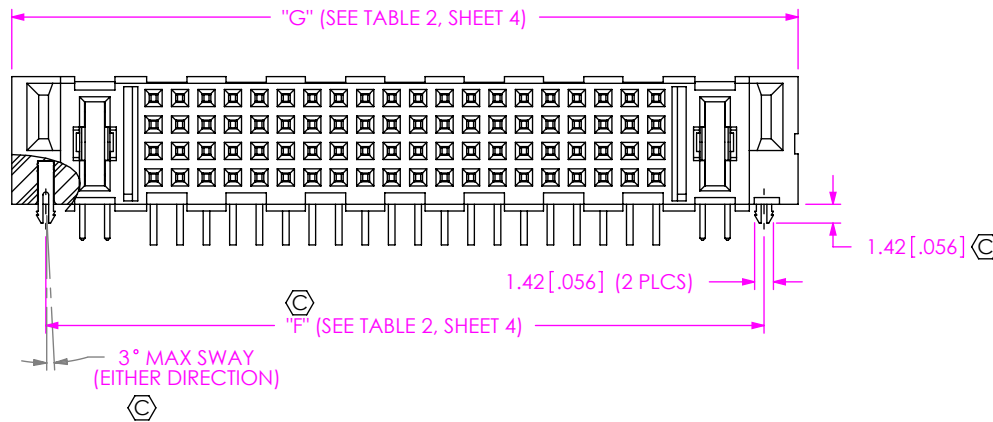
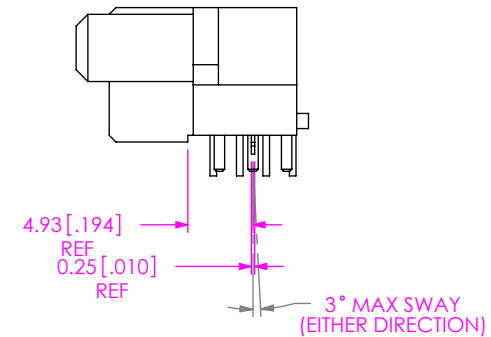

FIG 2  
 MPSC-01-80-01-01-01-X-RA-LC SHOWN  
 (SAME AS FIG 1, UNLESS OTHERWISE STATED)



**PROPRIETARY NOTE**  
 THIS DOCUMENT CONTAINS CONFIDENTIAL AND PROPRIETARY INFORMATION AND ALL DESIGN, MANUFACTURING, REPRODUCTION, USE, PATENT RIGHTS AND SALES RIGHTS ARE EXPRESSLY RESERVED BY SAMTEC, INC. THIS DOCUMENT SHALL NOT BE DISCLOSED, IN WHOLE OR PART, TO ANY UNAUTHORIZED PERSON OR ENTITY NOR REPRODUCED, TRANSFERRED OR INCORPORATED IN ANY OTHER PROJECT IN ANY MANNER WITHOUT THE EXPRESS WRITTEN CONSENT OF SAMTEC, INC.

DO NOT SCALE DRAWING  
 SHEET SCALE: 1:75:1



520 PARK EAST BLVD, NEW ALBANY, IN 47150  
 PHONE: 812-944-6733 FAX: 812-948-5047  
 e-Mail info@SAMTEC.com code 55322

DESCRIPTION:  
 RA MINI-POWER W/ SIGNAL SOCKET

DWG. NO.  
 MPSC-XX-XX-XX-01-XX-X-RA-XX

BY: BRATCHER 2/20/2007 SHEET 2 OF 4

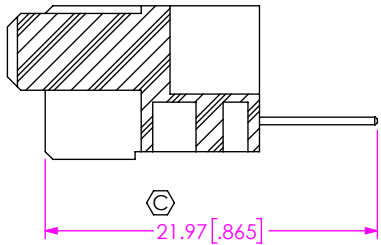

IN-PROCESS 1  
FILL C-79-XXX-X ROW 1

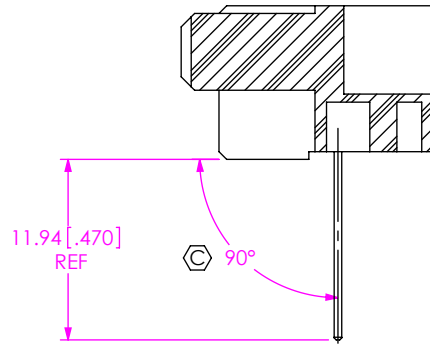

IN-PROCESS 2  
BEND ROW 1

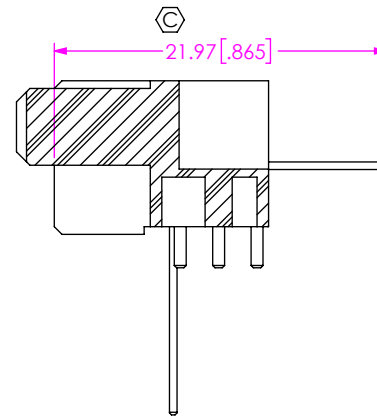

IN-PROCESS 3  
FILL C-79-XXX-X ROW 2

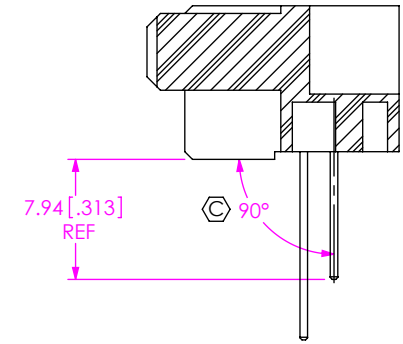

IN-PROCESS 4  
BEND ROW 2

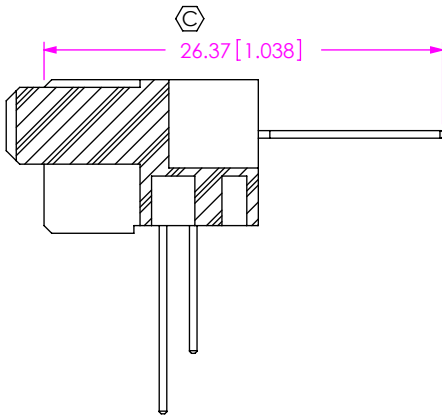

IN-PROCESS 5  
FILL C-79-XXX-X ROW 3

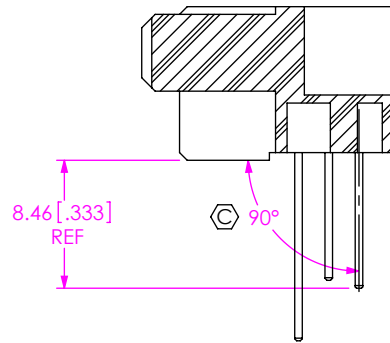

IN-PROCESS 6  
BEND ROW 3

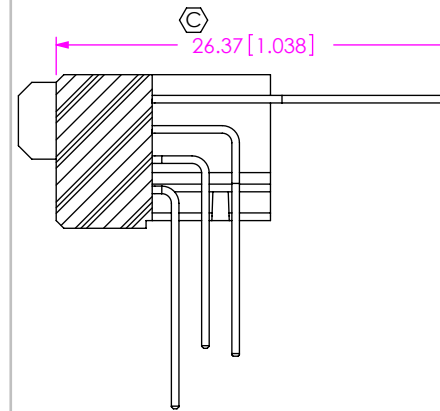

IN-PROCESS 7  
FILL C-79-XXX-X ROW 4

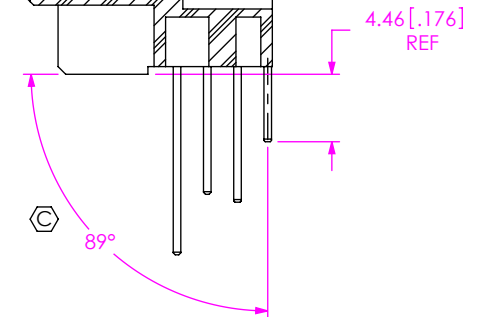

IN-PROCESS 8  
BEND ROW 4

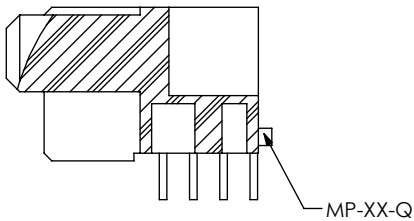

IN-PROCESS 9  
ADD MP-XX-Q

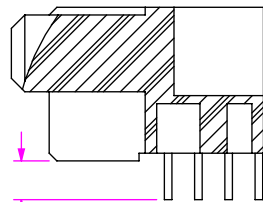

"A"  $\pm 0.25 [0.10]$   
(SEE TABLE 1, SHT 1)

IN-PROCESS 10  
SHEAR

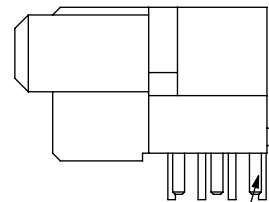

SUB-C-215-XX-X

IN-PROCESS 11  
FILL SUB-C-215-XX-X

F:\DWG\MISC\MKTG\MPSC-XX-XX-01-XX-X-RA-XX-MKT.SLDDRW

**PROPRIETARY NOTE**  
THIS DOCUMENT CONTAINS CONFIDENTIAL AND PROPRIETARY INFORMATION AND ALL DESIGN, MANUFACTURING, REPRODUCTION, USE, PATENT RIGHTS AND SALES RIGHTS ARE EXPRESSLY RESERVED BY SAMTEC, INC. THIS DOCUMENT SHALL NOT BE DISCLOSED, IN WHOLE OR PART, TO ANY UNAUTHORIZED PERSON OR ENTITY NOR REPRODUCED, TRANSFERRED OR INCORPORATED IN ANY OTHER PROJECT IN ANY MANNER WITHOUT THE EXPRESS WRITTEN CONSENT OF SAMTEC, INC.

DO NOT SCALE DRAWING

SHEET SCALE: 2:1



520 PARK EAST BLVD, NEW ALBANY, IN 47150  
PHONE: 812-944-6733 FAX: 812-948-5047  
e-Mail info@SAMTEC.com code 55322

DESCRIPTION:  
RA MINI-POWER W/ SIGNAL SOCKET

DWG. NO.  
MPSC-XX-XX-XX-01-XX-X-RA-XX

BY: BRATCHER 2/20/2007 SHEET 3 OF 4

TABLE 2								
PART NUMBER	BODY	"B" OAL -SD	"C"	"D"	"E"	"F"	"G"	"H"
MPSC-01-80-01-XX-XX-X-RA-XX	MPS-02-RA-80-XX	64.52 [2.540]	58.17 [2.290]	46.89 [1.846]	48.77 [1.920]	54.29 [2.137]	59.44 [2.340]	19
MPSC-02-80-02-XX-XX-X-RA-XX	MPS-04-RA-80-XX	74.52 [2.934]	68.17 [2.684]	56.89 [2.240]	58.77 [2.314]	64.29 [2.531]	69.44 [2.734]	19
MPSC-01-40-01-XX-XX-X-RA-SD	MPS-02-RA-40-SD	44.52 [1.753]	38.17 [1.503]	26.89 [1.059]	28.77 [1.133]	34.29 [1.350]	39.44 [1.553]	9
MPSC-01-24-01-XX-XX-X-RA-XX	MPS-02-RA-24-XX	36.52 [1.438]	30.17 [1.188]	18.89 [0.744]	20.77 [0.818]	26.29 [1.035]	31.44 [1.238]	5
MPSC-02-24-02-XX-XX-X-RA-XX	MPS-04-RA-24-XX	46.52 [1.831]	40.17 [1.581]	28.89 [1.137]	30.77 [1.211]	36.29 [1.429]	41.44 [1.631]	5
MPSC-01-16-01-XX-XX-X-RA-SD	MPS-02-RA-16-SD	32.52 [1.280]	26.17 [1.030]	14.89 [0.586]	16.77 [0.660]	22.29 [0.878]	27.44 [1.080]	3
MPSC-02-16-02-XX-XX-X-RA-SD	MPS-04-RA-16-SD	42.52 [1.674]	36.17 [1.424]	24.89 [0.980]	26.77 [1.054]	32.29 [1.271]	37.44 [1.474]	3
MPSC-00-24-03-XX-XX-X-RA-XX	MPS-03-RA-24-XX-PS	42.52 [1.674]	36.17 [1.424]	N/A	N/A	32.29 [1.271]	37.44 [1.474]	5
MPSC-00-24-04-XX-XX-X-RA-XX	MPS-04-RA-24-XX-PS	47.52 [1.871]	41.17 [1.621]	N/A	N/A	37.29 [1.468]	42.44 [1.671]	5
MPSC-00-20-03-XX-XX-X-RA-XX	MPS-03-RA-20-XX-PS	40.52 [1.595]	34.17 [1.345]	N/A	N/A	30.29 [1.193]	35.44 [1.395]	4
MPSC-00-20-04-XX-XX-X-RA-XX	MPS-04-RA-20-XX-PS	45.52 [1.792]	39.17 [1.542]	N/A	N/A	35.29 [1.389]	40.44 [1.592]	4
MPSC-00-16-03-XX-XX-X-RA-XX	MPS-03-RA-16-XX-PS	38.52 [1.517]	32.17 [1.267]	N/A	N/A	28.29 [1.114]	33.44 [1.317]	3
MPSC-00-16-04-XX-XX-X-RA-XX	MPS-04-RA-16-XX-PS	43.52 [1.713]	37.17 [1.463]	N/A	N/A	33.29 [1.311]	38.44 [1.513]	3
MPSC-00-12-03-XX-XX-X-RA-XX	MPS-03-RA-12-XX-PS	36.52 [1.438]	30.17 [1.188]	N/A	N/A	26.29 [1.035]	31.44 [1.238]	2
MPSC-00-12-04-XX-XX-X-RA-XX	MPS-04-RA-12-XX-PS	41.52 [1.635]	35.17 [1.385]	N/A	N/A	31.29 [1.232]	36.44 [1.435]	2

TABLE 3				
PLATING	POWER PIN CONTACT	POWER PIN TAIL	SIGNAL PIN CONTACT AREA	SIGNAL PIN TAIL
-L	10μ GOLD	MATTE TIN	10μ GOLD	MATTE TIN
-T	MATTE TIN	MATTE TIN	10μ GOLD	MATTE TIN

**PROPRIETARY NOTE**  
 THIS DOCUMENT CONTAINS CONFIDENTIAL AND PROPRIETARY INFORMATION AND ALL DESIGN, MANUFACTURING, REPRODUCTION, USE, PATENT RIGHTS AND SALES RIGHTS ARE EXPRESSLY RESERVED BY SAMTEC, INC. THIS DOCUMENT SHALL NOT BE DISCLOSED, IN WHOLE OR PART, TO ANY UNAUTHORIZED PERSON OR ENTITY NOR REPRODUCED, TRANSFERRED OR INCORPORATED IN ANY OTHER PROJECT IN ANY MANNER WITHOUT THE EXPRESS WRITTEN CONSENT OF SAMTEC, INC.

DO NOT SCALE DRAWING  
 SHEET SCALE: 1:75:1



520 PARK EAST BLVD, NEW ALBANY, IN 47150  
 PHONE: 812-944-6733 FAX: 812-948-5047  
 e-Mail info@SAMTEC.com code 55322

DESCRIPTION:  
 RA MINI-POWER W/ SIGNAL SOCKET

DWG. NO.  
 MPSC-XX-XX-XX-01-XX-X-RA-XX