

Amphenol SS10

© 2021 Amphenol Corporation

revision history				
rev	ecn no	description	dr	date
3	CDXXXX	FOLLOW TE SPEC BY CUSTOMER'S REQUEST	RH	2020/10/13
4	CDXXXX	ADD MYLAY DIMENSIONS	RH	2021/03/15
A	CD2440	OFFICIAL RELEASE	RH	2021/05/12

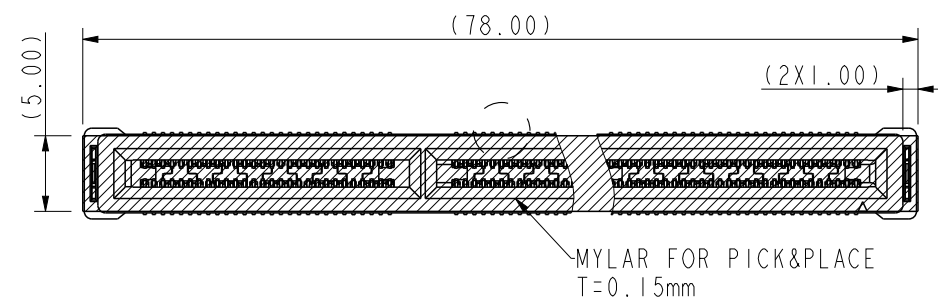
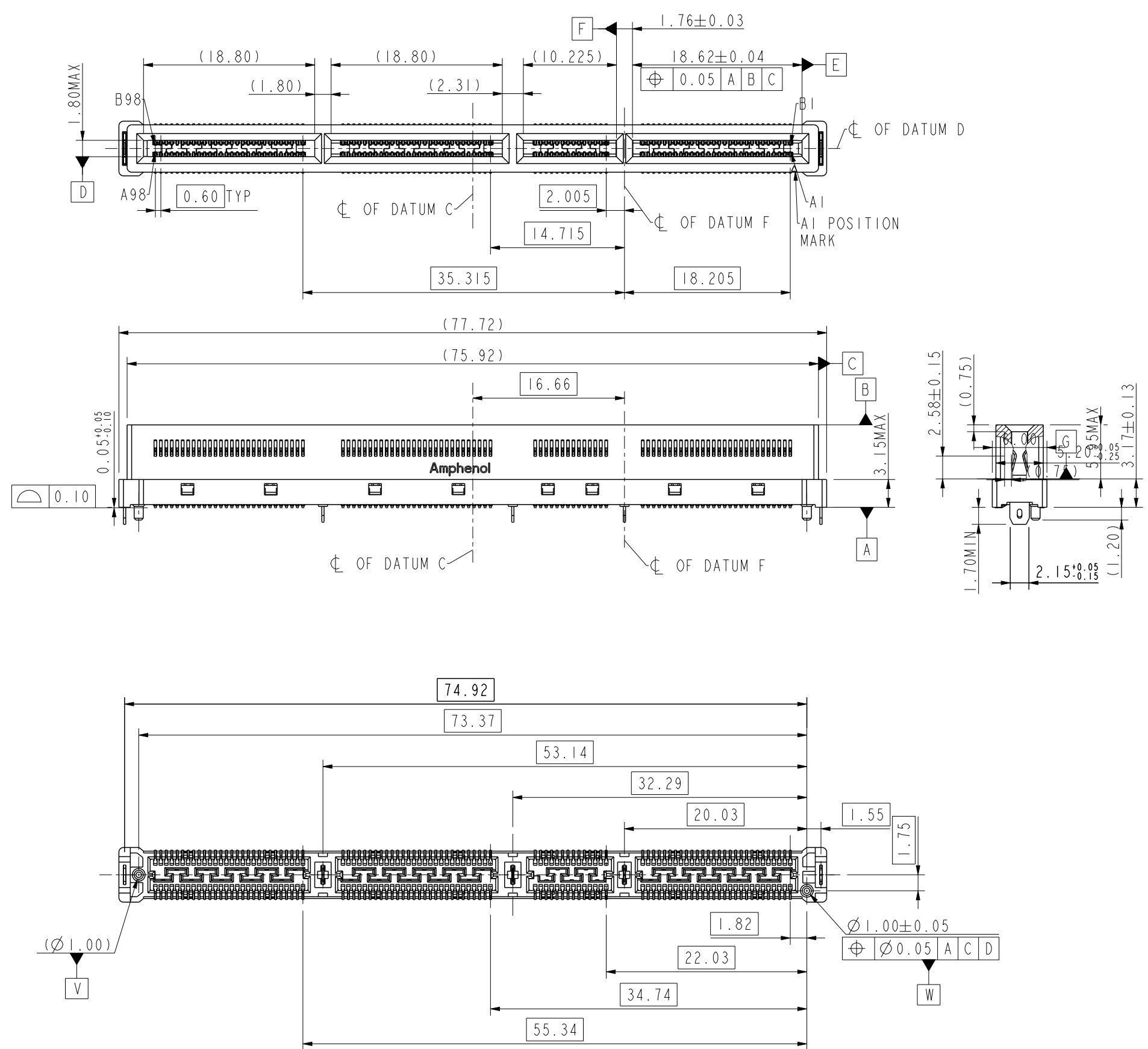

- NOTE:
- MATERIAL:**
HOUSING: HIGH TEMPERATURE THERMOPLASTIC BLACK UL94-V0.
CONTACT: COPPER ALLOY
BOARD LOCK: COPPER ALLOY
 - PLATING:**
CONTACT: MATING AREA: SEE PART NUMBER TABLE LIST
OVER 1.27um MIN NICKEL UNDERPLATED
SOLDER AREA: 1.27um MIN TIN OVER 1.27um MIN NICKEL UNDERPLATED
BOARD LOCK: 1.27um MIN TIN OVER 1.27um MIN NICKEL UNDERPLATED
 - ELECTRICAL PERFORMANCE:**
RATED CURRENT: 1.1A/PIN UP TO 12PINS
LLCR: DELTA 15mΩ MAX
INSULATION RESISTANCE: 1000MΩ MIN.
 - MECHANICAL PERFORMANCE:**
MATING FORCE: 107.8N MAX.
UNMATING FORCE: 9.8N MIN
DURABILITY: 200CYCLES
 - CONNECTOR IS ROHS COMPLIANT
 - ORDERING PN SEE BELOW PART NUMBER TABLE LIST.

ME1019610101015	GXT 0.38um
ME1019610101014	GXT 0.76um
ME1019610101013	GOLD FLASH
ME1019610101012	0.38um Au
ME1019610101011	0.76um Au
PART NUMBER	PLATING SPEC
PART NUMBER LIST TABLE	

spec ref	S-ME-004	dr	Rocky Huang	2022/12/20	
tolerance std	TOLERANCES UNLESS OTHERWISE SPECIFIED	eng	Rocky Huang	2022/12/20	
surface		linear 0.X ± 0.25 0.XX ± 0.20 0.XXX ± 0.15 angular 0° ± 5°	r vwr	Johnny Wang	2022/12/20
			appr	LY Yi	2022/12/20
			projection		
title		MINI COOL EDGE CONNECTOR V/T, 196PIN, 0.60mm PITCH, SMT			
product family					

Amphenol SS10

mm scale 2:1 size A3

ecn no - rel level Released

amphenol-icc.com

part no C ME101961010101X rev A

cat. no. sheet 1 of 3

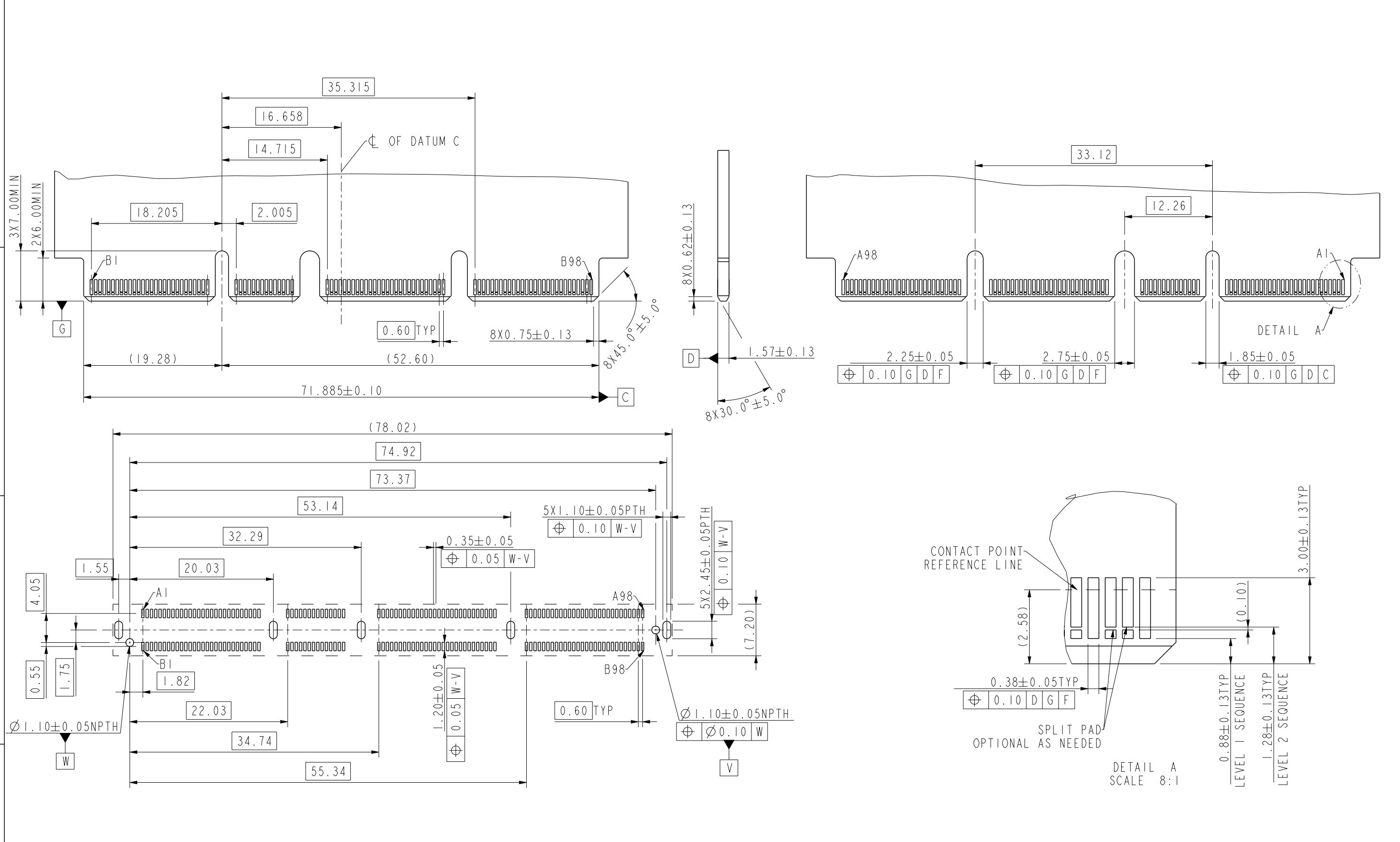

spec ref	S-ME-004	dr	Rocky Huang	2022/12/20	<h1>Amphenol SS10</h1>	mm	scale	2:1	size	A3	
tolerance std	TOLERANCES UNLESS OTHERWISE SPECIFIED	eng	Rocky Huang	2022/12/20		ecn no	-	rel level	Released		
surface	linear 0.X ± 0.25 0.XX ± 0.20 0.XXX ± 0.15 angular 0° ± 5°	projection	Johnny Wang	2022/12/20		amphenol-icc.com		cat. no.	C ME101961010101X	rev	A
		V/T, 196PIN, 0.60mm PITCH, SMT	LY Yi	2022/12/20				product family		sheet 2 of 3	

Creo File:APH-SS10-A3C_REV B_2021-05-07

**Amphenol
SS10**

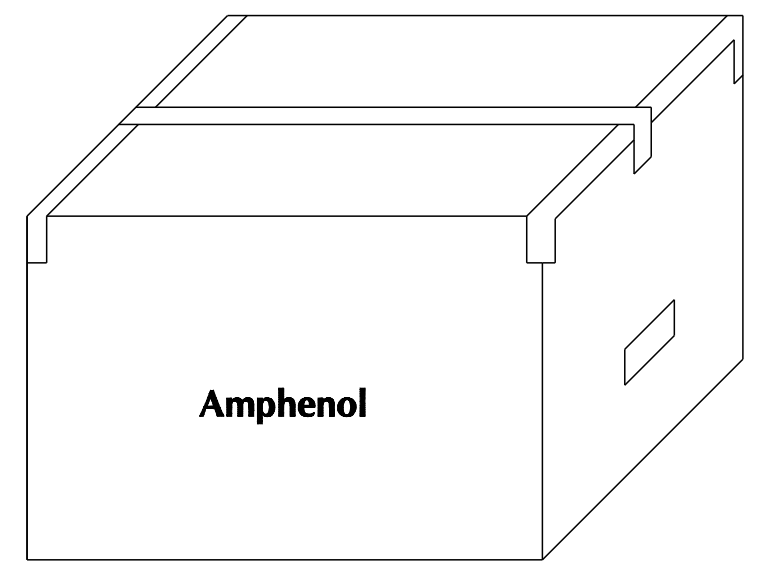
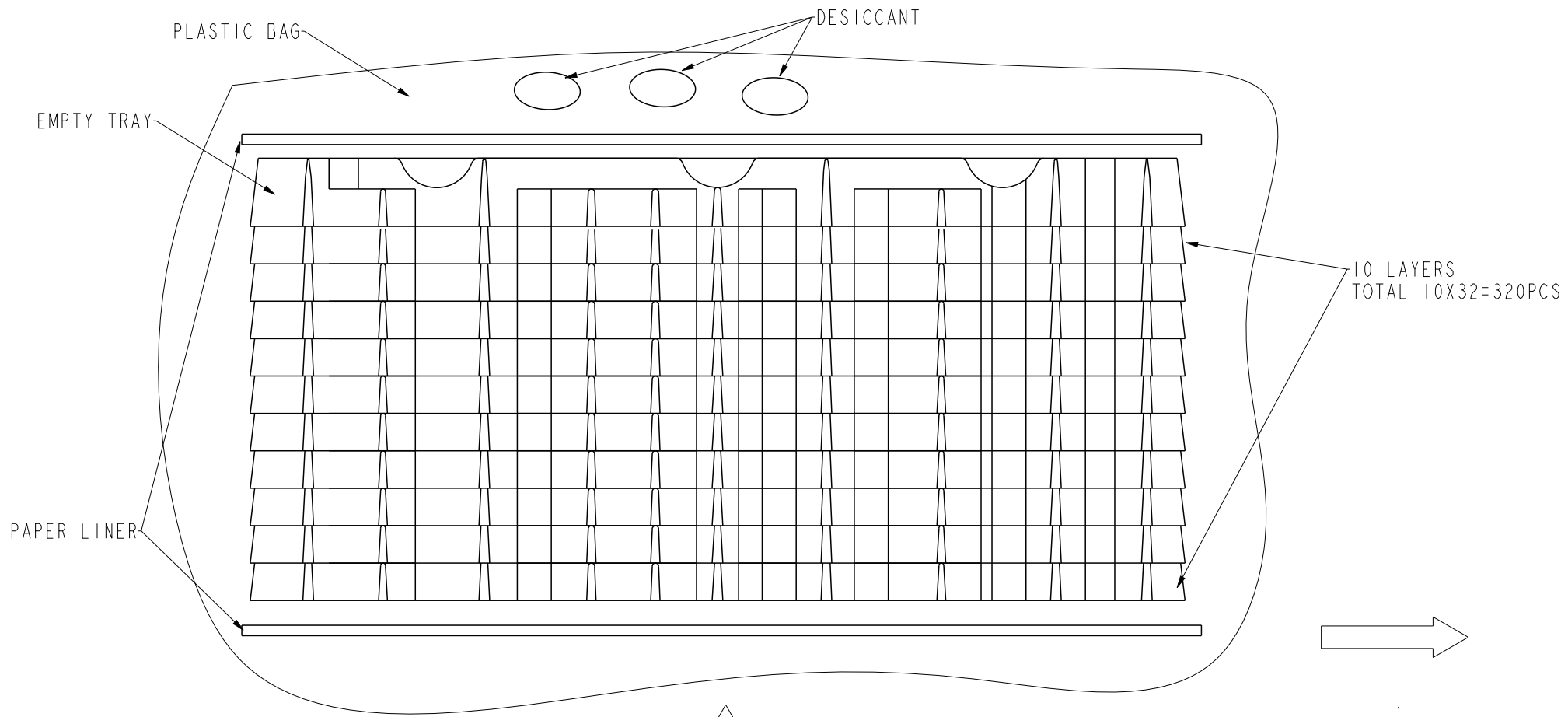

320PCS/CARTON
CARTON SIZE; 335X245X225

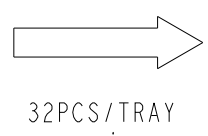
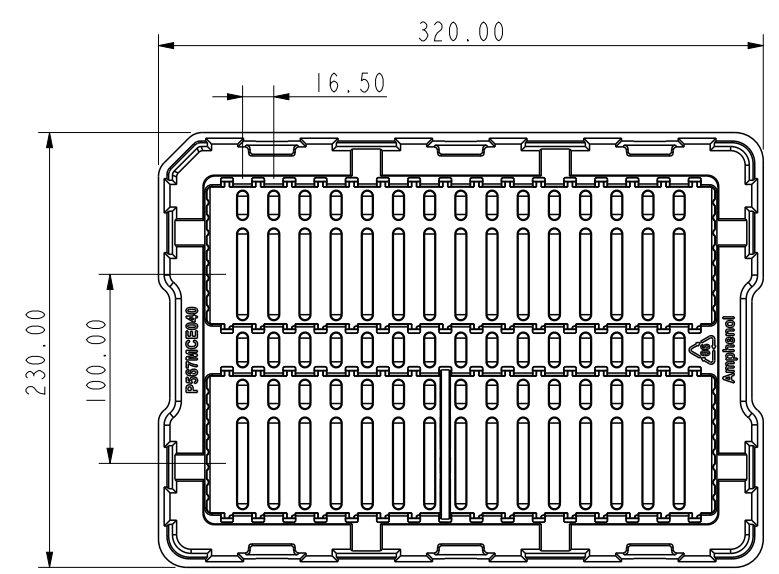

© 2021 Amphenol Corporation

spec ref	S-ME-004		dr	Rocky Huang	2022/12/20	Amphenol SS10	mm	scale	2:1	size	A3	
tolerance std	TOLERANCES UNLESS OTHERWISE SPECIFIED		eng	Rocky Huang	2022/12/20			ecn no				
surface	linear	0.X	± 0.25	r vwr	Johnny Wang			2022/12/20	rel level	Released		
		0.XX	± 0.20	appr	LY Yi			2022/12/20				
		0.XXX	± 0.15	projection		product family		MINI COOL EDGE CONNECTOR	cat. no.	C ME10196101010IX	rev	A
		angular	0°	± 5°	product family		product family		sheet 3 of 3			