

LS37

T-43-15-00



54LS37/DM74LS37

Quad 2-Input NAND Buffers

General Description

This device contains four independent buffer gates each of which performs the logic NAND function.

Connection Diagram

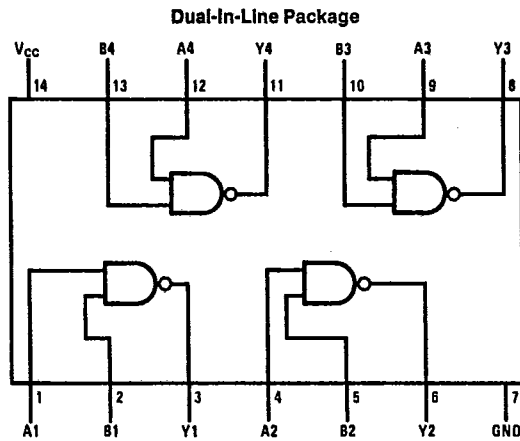

TL/F/8382-1

Order Number 54LS37DMQB, 54LS37FMQB, 54LS37LMQB,
DM74LS37M or DM74LS37N
See NS Package Number E20A, J14A, M14A, N14A or W14B

Function Table

$$Y = \overline{AB}$$

Inputs		Output
A	B	Y
L	L	H
L	H	H
H	L	H
H	H	L

H = High Logic Level
L = Low Logic Level

LS37

Absolute Maximum Ratings (Note)

T-43-15

If Military/Aerospace specified devices are required, please contact the National Semiconductor Sales Office/Distributors for availability and specifications.

Note: The "Absolute Maximum Ratings" are those values beyond which the safety of the device cannot be guaranteed. The device should not be operated at these limits. The parametric values defined in the "Electrical Characteristics" table are not guaranteed at the absolute maximum ratings. The "Recommended Operating Conditions" table will define the conditions for actual device operation.

Supply Voltage	7V
Input Voltage	7V
Operating Free Air Temperature Range	
54LS	-55°C to +125°C
DM74LS	0°C to +70°C
Storage Temperature Range	-65°C to +150°C

Recommended Operating Conditions

Symbol	Parameter	54LS37			DM74LS37			Units
		Min	Nom	Max	Min	Nom	Max	
V _{CC}	Supply Voltage	4.5	5	5.5	4.75	5	5.25	V
V _{IH}	High Level Input Voltage	2			2			V
V _{IL}	Low Level Input Voltage			0.7			0.8	V
I _{OH}	High Level Output Current			-1.2			-1.2	mA
I _{OL}	Low Level Output Current			12			24	mA
T _A	Free Air Operating Temperature	-55		125	0		70	°C

Electrical Characteristics over recommended operating free air temperature range (unless otherwise noted)

Symbol	Parameter	Conditions	Min	Typ (Note 1)	Max	Units
V _I	Input Clamp Voltage	V _{CC} = Min, I _I = -18 mA			-1.5	V
V _{OH}	High Level Output Voltage	V _{CC} = Min, I _{OH} = Max V _{IL} = Max	54LS 2.5			V
V _{OL}	Low Level Output Voltage	V _{CC} = Min, I _{OL} = Max V _{IH} = Min	54LS		0.4	V
			DM74LS	0.35	0.5	
		I _{OL} = 12 mA, V _{CC} = Min		0.25	0.4	
I _I	Input Current @ Max Input Voltage	V _{CC} = Max, V _I = 10V (54LS) V _I = 7V (DM74LS)			0.1	mA
I _{IH}	High Level Input Current	V _{CC} = Max, V _I = 2.7V			20	μA
I _{IL}	Low Level Input Current	V _{CC} = Max, V _I = 0.4V	54LS		-0.40	mA
			DM74LS		-0.36	
I _{OS}	Short Circuit Output Current	V _{CC} = Max (Note 2)	54LS	-30	-130	mA
			DM74LS	-20	-100	
I _{CCH}	Supply Current with Outputs High	V _{CC} = Max		0.9	2	mA
I _{CCL}	Supply Current with Outputs Low	V _{CC} = Max		6	12	mA

Switching Characteristics at V_{CC} = 5V and T_A = 25°C (See Section 1 for Test Waveforms and Output Load)

Symbol	Parameter	54LS		DM74LS		Units
		C _L = 50 pF		C _L = 150 pF, R _L = 687Ω		
		Min	Max	Min	Max	
t _{PLH}	Propagation Delay Time Low to High Level Output		20	4	18	ns
t _{PHL}	Propagation Delay Time High to Low Level Output		20	4	21	ns

Note 1: All typicals are at V_{CC} = 5V, T_A = 25°C.

Note 2: Not more than one output should be shorted at a time, and the duration should not exceed one second.

2