

PART NUMBER	REVISION	DESCRIPTION	FEED TYPE
2150056-2	D	FINE CRIMP HEIGHT ADJUST	PNEUMATIC
7-2150056-2	D	PNEUMATIC AND CRIMP TOOLING KIT	PNEUMATIC
7-2150056-7	A	CRIMP TOOLING KIT	-

ATLANTIC VERSION TERMINATOR INTERFACE ADAPTER

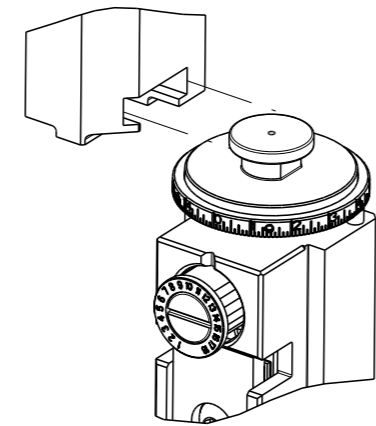

APPLICATOR DATA		
CRIMP	SIZE	TYPE
WIRE	3.56 mm [.140]	F
INSUL	7.87 mm [.310]	F

APPLICATOR INSTRUCTIONS 408-35043

TERMINAL DATA: TE TERMINAL		TE CRIMP SPECIFICATION	
TERMINAL NAME: RECEPTACLE, FASTON .250 SERIES			
WIRE STRIP LENGTH		INSULATION DIAMETER RANGE	
6.02-6.78 mm [.237-.267 IN]		∅ 5.72-6.99 mm [.225-.275 IN] OR (2) ∅ 3.56 mm [.140 IN]	
TERMINAL APPLICATION SPECIFICATION	114-2036		
TERMINALS APPLIED			
TE TERMINAL	TE TERMINAL	TE TERMINAL	TE TERMINAL
60635-1	60635-3	63539-1	1742915-1
60635-2	63419-1	63539-2	

WIRE SIZE	CRIMP HEIGHT mm [INCH]	CRIMP HEIGHT REFERENCE SETTING
10 AWG	2.67 +/- 0.05 [.105 +/- .002]	3.4
(2) 14 AWG	2.39 +/- 0.05 [.094 +/- .002]	5.9
12 AWG	2.24 +/- 0.05 [.088 +/- .002]	8.4
14 AWG	1.93 +/- 0.05 [.076 +/- .002]	11.7



- RECOMMENDED SPARE PARTS
- REFER TO SUPPLIED INSTRUCTION SHEET FOR CLEANING, LUBRICATION AND STORAGE OF APPLICATOR.
- APPLY PART NUMBER 2-23419-6 LOCTITE TO THREADS OF ITEM 242. APPLY PART NUMBER 1-23419-5 LOCTITE TO THREADS OF ITEM 50.
- CRIMP HEIGHT REFERENCE SETTING WAS THE SETTING USED WHEN THE APPLICATOR WAS QUALIFIED AT THE FACTORY. ADJUSTMENT MAY BE NECESSARY WHEN RUNNING APPLICATOR IN THE FIELD.
- TERMINAL PITCH NOT COMPATIBLE WITH MECHANICAL FEED.
- 6. UNLESS SPECIFIED OTHERWISE TORQUE VALUES SHALL BE USED PER DOCUMENT, 101-35000.
- 9600 MAX CMA.

***WARNING**
ON INSTALLATION, SET WIRE DISC TO CRIMP HEIGHT REFERENCE SETTING FOR LARGEST WIRE SIZE. CRIMP HEIGHT REFERENCE SETTINGS GREATER THAN THE VALUE SHOWN MAY CAUSE DAMAGE TO THE CRIMP TOOLING. REFER TO THE INSTRUCTION SHEET FOR PROPER SETUP AND ADJUSTMENTS.

ATLANTIC VERSION
Shown on sheets 1 of 4 & 2 of 4
(Pacific version shown on sheets 3 of 4 & 4 of 4)

LOC	DIST	REVISIONS					
		P	LY#	DESCRIPTION	DATE	OWN	APVD
A	66	B		ECR-13-011562	22JUL2013	XZ	TE
		B1		ECR-18-004774	29MAR2018	AW	CT
		C		ECR-18-014714	17SEP2018	TB	TE
		D		ECR-19-008437	29MAY2019	LG	TE

-	1	1	2119641-1	FEED CAM, AIR FEED	248	
-	1	1	2119082-9	CAM, SNAIL, INSULATION ADJUSTMENT	244	
-	1	1	2079764-1	WASHER, WAVE SPRING, CREST-TO-CREST	243	
-	1	1	2119083-1	RETAINER, INSULATION DIAL	242	
-	1	1	2844940-4	AIR FEED MODULE	238	
-	1	1	1-18028-0	WASHER, FLAT, REG M8	192	
-	1	1	6-9931111-6	PIN, SLOTTED SPRING 3.0 X 14.0	177	
-	1	1	8-22280-7	SPRING, COMPRESSION	176	
-	1	1	1752353-2	GUIDE PIN, HOLDDOWN	175	
-	1	1	1901680-2	GUIDE PIN, HOLDDOWN	174	
-	REF	REF	994970-2	COUNTER, MAGNETIC	164	
-	1	1	455888-6	SPACER, CRIMPER	82	
-	1	1	2119791-5	DEPRESSOR, WIRE	73	
-	1	1	1803607-4	DOCUMENTATION PACKAGE	71	
-	2	2	2-18032-2	SCR, SET, FLT PNT, M3 X 10.0	70	
-	1	1	2119943-1	WASHER, SPACER	69	
-	1	1	2119740-1	TAG, IDENTIFICATION	67	
-	2	2	2168078-1	SCREW, DRIVE, RH, RoHS, 2 x .188	66	
-	1	1	1901681-5	HOLDDOWN, TERMINAL	65	
-	2	2	2168400-5	SHCS, LOW HEAD, RoHS, M4 X 20	64	
-	1	1	2168083-2	SCR, SKT HD CAP, RoHS, M4 X 8.0	60	
-	1	1	5-18022-5	SCR, HEX HD CAP, M4 X 6.0	59	
-	3	3	2168400-4	SHCS, LOW HEAD, RoHS, M4 X 8	57	
-	2	2	1-2168083-0	SCR, SKT HD CAP, RoHS, M4 X 10	56	
-	2	2	5018030-1	NUT, HEX, REG, RoHS, M3	54	
-	2	2	986965-8	NUT, LOCK, HEX, TORQUE (M4)	53	
-	1	1	1-5018030-0	NUT, HEX, REG, RoHS, M3.5	52	
-	1	1	2063961-9	FEED FINGER	51	
-	1	1	1-1976055-3	STANDOFF, HOLD-DOWN	50	
-	1	1	18023-9	SCR, SKT HD CAP M4 X 6.0	49	
-	1	1	2119655-5	APPLICATOR BASIC ASSEMBLY, EF	46	
-	1	1	1803517-1	RAM ASSEMBLY, EF ATLANTIC	44	
-	1	1	1803602-1	SCR, BHSC, RoHS (M8 X 25)	41	
-	7	7	1-18028-2	WASHER, FLAT, REG M4	33	
-	2	2	2168083-9	SCR, SKT HD CAP, RoHS, M4 X 20	31	
-	2	2	2168083-2	SCR, SKT HD CAP, RoHS, M4 X 8.0	29	
-	1	1	690455-2	STRIPPER, FRONT CASTING	27	
-	2	2	1-2168083-5	SCR, SKT HD CAP, RoHS, M4 X 30	25	
-	1	1	1-1752371-2	PLATE, STRIP GUIDE	24	
-	1	1	240825-5	PLATE, STRIP HOLD DOWN	23	
-	2	2	2-22281-3	SPRING, COMPRESSION	22	
-	1	1	1803292-4	DRAG	20	
-	2	2	1901259-6	GUIDE, LOWER STRIP	18	
-	4	4	1-2079383-1	SCR, BHSC, RoHS (M6 X 12)	17	
-	1	1	6-240641-3	SPACER	16	
-	1	1	1752360-1	SPACER, HOLD-DOWN	13	
-	1	1	240644-5	PLATE, REAR SHEAR	11	
-	1	1	4-690495-3	PLATE, FRONT SHEAR	9	
-	1	2	1	4-1633383-8	ANVIL, COMBINATION	8
-	1	1	1	690474-8	BLADE, SLUG	7
-	1	1	1	240641-1	SPACER	5
-	1	1	1	238011-2	BLOCK, CRIMPER SPACER	4
-	1	2	1	4-2119582-0	CRIMPER, INSULATION F PREMIUM	3
-	1	1	1	455888-4	SPACER, CRIMPER	2
-	1	2	1	456411-9	CRIMPER, WIRE PREMIUM	1
-	77	72	2	PART NO	DESCRIPTION	ITEM NO

DIMENSIONS:		TOLERANCES UNLESS OTHERWISE SPECIFIED:		DRAWING NO		NAME	
mm	0 PLC ±	1 PLC ±	2 PLC ±	3 PLC ±	4 PLC ±	SIZE	CAGE CODE
	ANGLES	FINISH				00779	2150056
MATERIAL				WEIGHT		SCALE	
						1:1	

Customer Accessible Production Drawing

LOC		DIST		REVISIONS			
A	66	P	LYR	DESCRIPTION	DATE	OWN	APVD
		-		SEE SHEET 1	-	-	-

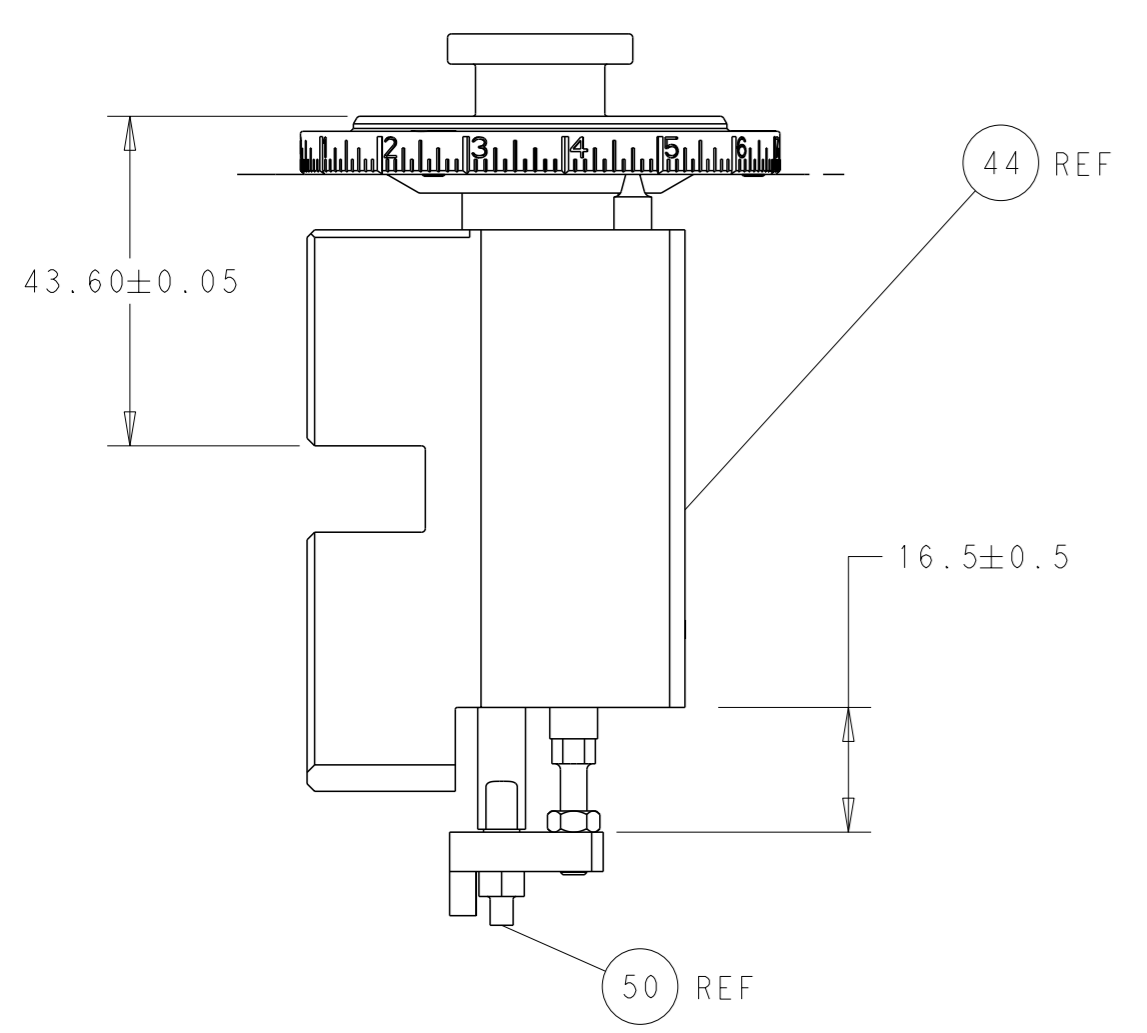

RAM AND HOLDDOWN SET-UP

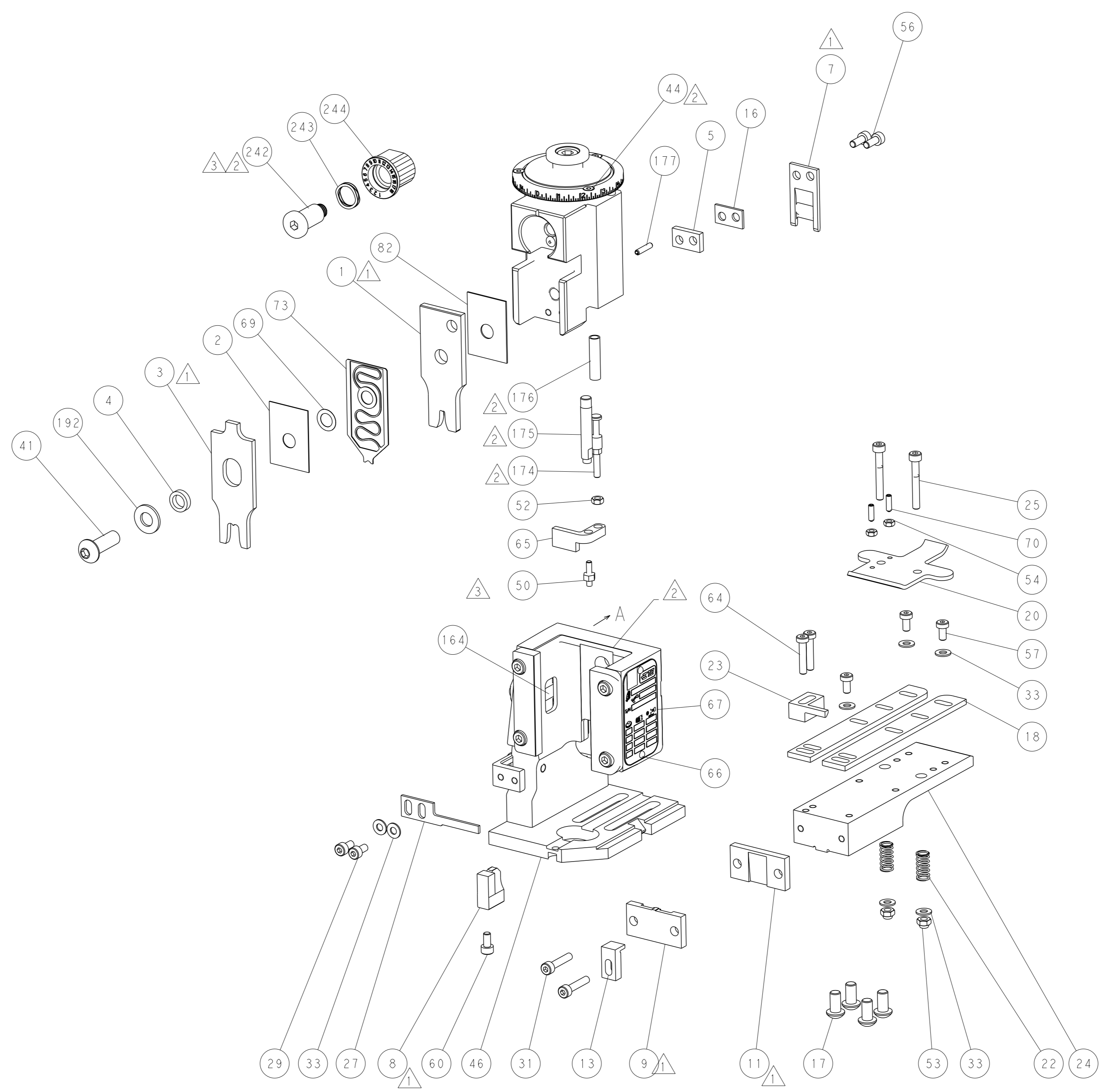

FEED TYPE

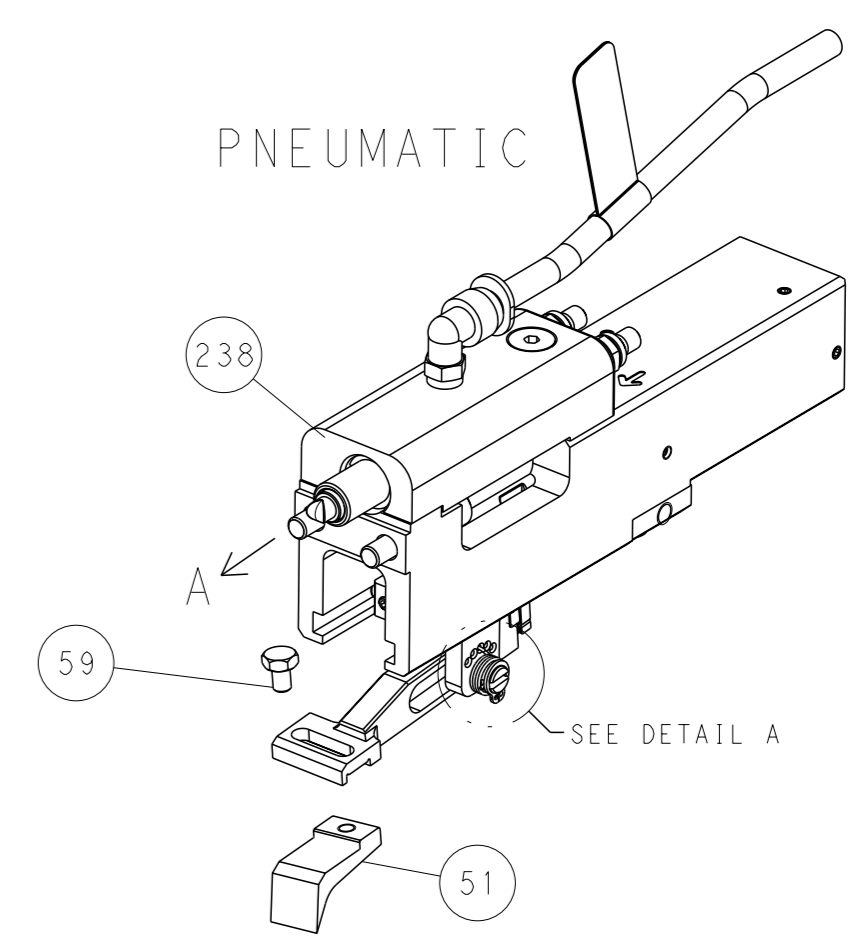

FEED SPRING SETTING POSITION

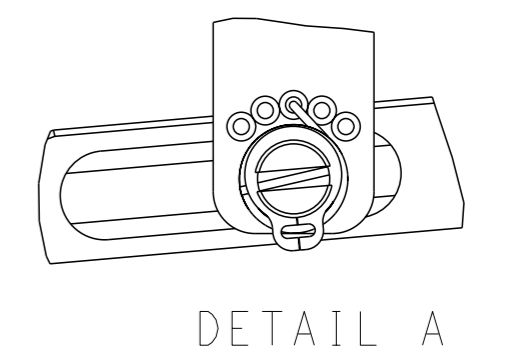

CAM POSITIONS

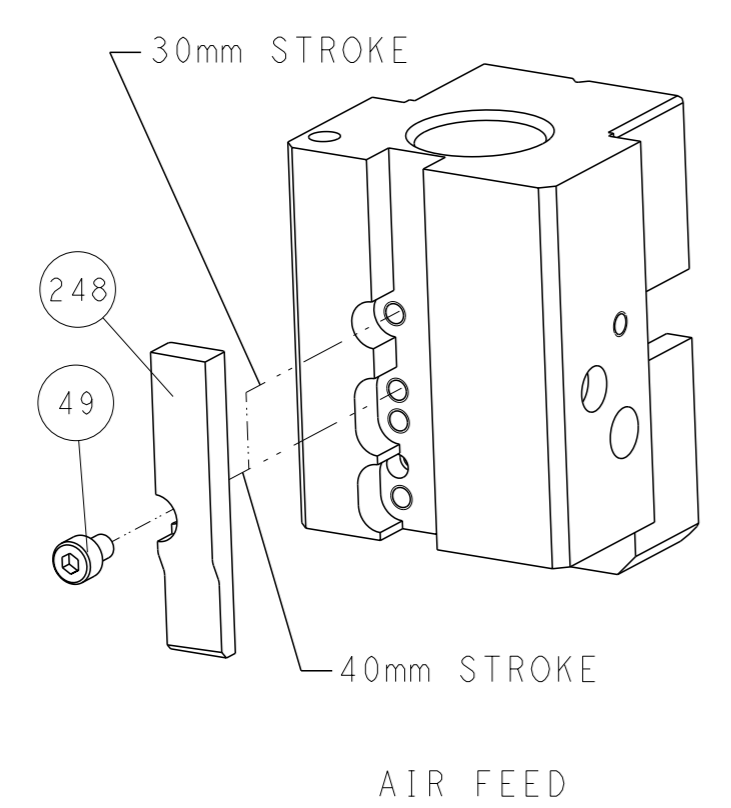

ATLANTIC VERSION
 Shown on sheets 1 of 4 & 2 of 4
 (Pacific version shown on sheets 3 of 4 & 4 of 4)

<small>THIS DRAWING IS A CONTROLLED DOCUMENT FROM TYCO ELECTRONICS CORPORATION. IT IS SUBJECT TO CHANGE AND THE CONTROL AND REVISIONS DISPOSITION SHOULD BE CONTACTED FOR THE LATEST REVISION.</small>		DWN L. ZHANG 03FEB2012 CHK L. ZHANG 03FEB2012 APVD S. XI 03FEB2012	TE Connectivity Harrisburg, PA 17105-3608
DIMENSIONS: mm TOLERANCES UNLESS OTHERWISE SPECIFIED: 0 PLC ± 1 PLC ± 2 PLC ± 3 PLC ± 4 PLC ± ANGLES FINISH ±		NAME Ocean End Feed Applicator PRODUCT SPEC APPLICATION SPEC WEIGHT SCALE 1:1	SIZE A1 CAGE CODE 00779 DRAWING NO. C=2150056 SHEET 2 of 4 REV D
MATERIAL:		Customer Accessible Production Drawing	

PART NUMBER	REVISION	DESCRIPTION	FEED TYPE
2-2150056-2	D	FINE CRIMP HEIGHT ADJUST	PNEUMATIC
7-2150056-7	A	CRIMP TOOLING KIT	-

PACIFIC VERSION TERMINATOR
 INTERFACE ADAPTER

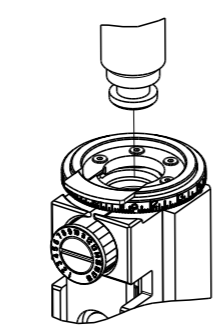

APPLICATOR DATA

CRIMP	SIZE	TYPE
WIRE	3.56 mm [1.40]	F
INSUL	7.87 mm [3.10]	F

APPLICATOR INSTRUCTIONS
 408-35043

TERMINAL DATA: TE TERMINAL TE CRIMP SPECIFICATION

TERMINAL NAME: RECEPTACLE, FASTON .250 SERIES

WIRE STRIP LENGTH	INSULATION DIAMETER RANGE
6.02-6.78 mm [2.37-.267 IN]	∅ 5.72-6.99 mm [1.225-.275 IN] OR (2) ∅ 3.56 mm [1.40 IN]

TERMINAL APPLICATION SPECIFICATION 114-2036

TERMINALS APPLIED

TE TERMINAL	TE TERMINAL	TE TERMINAL	TE TERMINAL
60635-1	60635-3	63539-1	1742915-1
60635-2	63419-1	63539-2	

WIRE SIZE	CRIMP HEIGHT mm [INCH]	CRIMP HEIGHT REFERENCE SETTING
10 AWG	2.67+/-0.05 [1.105+/-0.002]	3.4
(2)14 AWG	2.39+/-0.05 [1.094+/-0.002]	5.9
12 AWG	2.24+/-0.05 [1.088+/-0.002]	8.4
14 AWG	1.93+/-0.05 [1.076+/-0.002]	11.7

- 1 RECOMMENDED SPARE PARTS
- 2 REFER TO SUPPLIED INSTRUCTION SHEET FOR CLEANING, LUBRICATION AND STORAGE OF APPLICATOR.
- 3 APPLY PART NUMBER 2-23419-6 LOCTITE TO THREADS OF ITEM 242. APPLY PART NUMBER 1-23419-5 LOCTITE TO THREADS OF ITEM 50.
- 4 CRIMP HEIGHT REFERENCE SETTING WAS THE SETTING USED WHEN THE APPLICATOR WAS QUALIFIED AT THE FACTORY. ADJUSTMENT MAY BE NECESSARY WHEN RUNNING APPLICATOR IN THE FIELD.
- 5 TERMINAL PITCH NOT COMPATIBLE WITH MECHANICAL FEED.
- 6. UNLESS SPECIFIED OTHERWISE TORQUE VALUES SHALL BE USED PER DOCUMENT, 101-35000.
- 7 9600 MAX CMA.

***WARNING**
 ON INSTALLATION, SET WIRE DISC TO CRIMP HEIGHT REFERENCE SETTING FOR LARGEST WIRE SIZE. CRIMP HEIGHT REFERENCE SETTINGS GREATER THAN THE VALUE SHOWN MAY CAUSE DAMAGE TO THE CRIMP TOOLING. REFER TO THE INSTRUCTION SHEET FOR PROPER SETUP AND ADJUSTMENTS.

PACIFIC VERSION
 Shown on sheets 3 of 4 & 4 of 4
 (Atlantic version shown on sheets 1 of 4 & 2 of 4)

LOC	DIST	REVISIONS				
		P	LYR	DATE	OWN	APVD
A	66	-	-	SEE SHEET 1	-	-

-	1	2119082-9	CAM, SNAIL, INSULATION ADJUSTMENT	244
-	1	2079764-1	WASHER, WAVE SPRING, CREST-TO-CREST	243
-	1	2119083-1	RETAINER, INSULATION DIAL	242
-	1	2844940-4	AIR FEED MODULE	238
-	1	1-18028-0	WASHER, FLAT, REG M8	192
-	4	2079383-9	SCR, BHSC, RoHS (M6 X 20)	186
-	1	6-993111-6	PIN, SLOTTED SPRING 3.0 X 14.0	177
-	1	8-22280-7	SPRING, COMPRESSION	176
-	1	1752353-2	GUIDE PIN, HOLDDOWN	175
-	1	1901680-2	GUIDE PIN, HOLDDOWN	174
-	REF	994970-2	COUNTER, MAGNETIC	164
-	1	2119641-2	FEED CAM, AIR FEED	152
-	1	2168083-8	SCR, SKT HD CAP, RoHS, M4 X 16	144
-	1	2119656-6	APPLICATOR BASIC ASSEMBLY, EF	141
-	1	1803518-1	RAM ASSEMBLY, EF PACIFIC	140
-	1	455888-6	SPACER, CRIMPER	82
-	1	2119791-5	DEPRESSOR, WIRE	73
-	1	1803607-4	DOCUMENTATION PACKAGE	71
-	2	2-18032-2	SCR, SET, FLT PNT, M3 X 10.0	70
-	1	2119943-1	WASHER, SPACER	69
-	1	2119740-1	TAG, IDENTIFICATION	67
-	2	2168078-1	SCREW, DRIVE, RH, RoHS, 2 x .188	66
-	1	1901681-5	HOLDDOWN, TERMINAL	65
-	2	2168400-5	SHCS, LOW HEAD, RoHS, M4 X 20	64
-	1	5-18022-5	SCR, HEX HD CAP, M4 X 6.0	59
-	3	2168400-4	SHCS, LOW HEAD, RoHS, M4 X 8	57
-	2	1-2168083-0	SCR, SKT HD CAP, RoHS, M4 X 10	56
-	2	5018030-1	NUT, HEX, REG, RoHS, M3	54
-	2	986965-8	NUT, LOCK, HEX, TORQUE (M4)	53
-	1	1-5018030-0	NUT, HEX, REG, RoHS, M3.5	52
-	1	2063961-9	FEED FINGER	51
-	1	1-1976055-3	STANDOFF, HOLD-DOWN	50
-	1	18023-9	SCR, SKT HD CAP M4 X 6.0	49
-	1	1803602-1	SCR, BHSC, RoHS (M8 X 25)	41
-	7	1-18028-2	WASHER, FLAT, REG M4	33
-	2	2168083-9	SCR, SKT HD CAP, RoHS, M4 X 20	31
-	2	2168083-2	SCR, SKT HD CAP, RoHS, M4 X 8.0	29
-	1	690455-2	STRIPPER, FRONT CASTING	27
-	2	1-2168083-5	SCR, SKT HD CAP, RoHS, M4 X 30	25
-	1	1-1752371-2	PLATE, STRIP GUIDE	24
-	1	240825-5	PLATE, STRIP HOLD DOWN	23
-	2	2-22281-3	SPRING, COMPRESSION	22
-	1	1803292-4	DRAG	20
-	2	1901259-6	GUIDE, LOWER STRIP	18
-	1	6-240641-3	SPACER	16
-	1	1752360-1	SPACER, HOLD-DOWN	13
-	1	240644-5	PLATE, REAR SHEAR	11
-	1	4-690495-3	PLATE, FRONT SHEAR	9
-	1	4-1633383-8	ANVIL, COMBINATION	8
-	1	690474-8	BLADE, SLUG	7
-	1	240641-1	SPACER	5
-	1	238011-2	BLOCK, CRIMPER SPACER	4
-	1	4-2119582-0	CRIMPER, INSULATION F PREMIUM	3
-	1	455888-4	SPACER, CRIMPER	2
-	1	456411-9	CRIMPER, WIRE PREMIUM	1

DIMENSIONS:		TOLERANCES UNLESS OTHERWISE SPECIFIED:		OWN	CHK	APPV	DATE	NAME	PRODUCT SPEC	APPLICATION SPEC	SIZE	CAGE CODE	DRAWING NO	RESTRICTED TO	
mm	0 PLC ±	1 PLC ±	2 PLC ±	3 PLC ±	4 PLC ±	FINISH	ANGLES	FINISH	WT	WT	WT	WT	WT	WT	
MATERIAL		FINISH		L. ZHANG		03FEB2012		L. ZHANG		03FEB2012		S. YI		03FEB2012	
Customer Accessible Production Drawing		SCALE 1:1		SHEET 3		OF 4		REV D		00779		©=2150056		-	

LOC	DIST	REVISIONS			
A	66	REV	DATE	OWN	APVD
		-	SEE SHEET 1	-	-

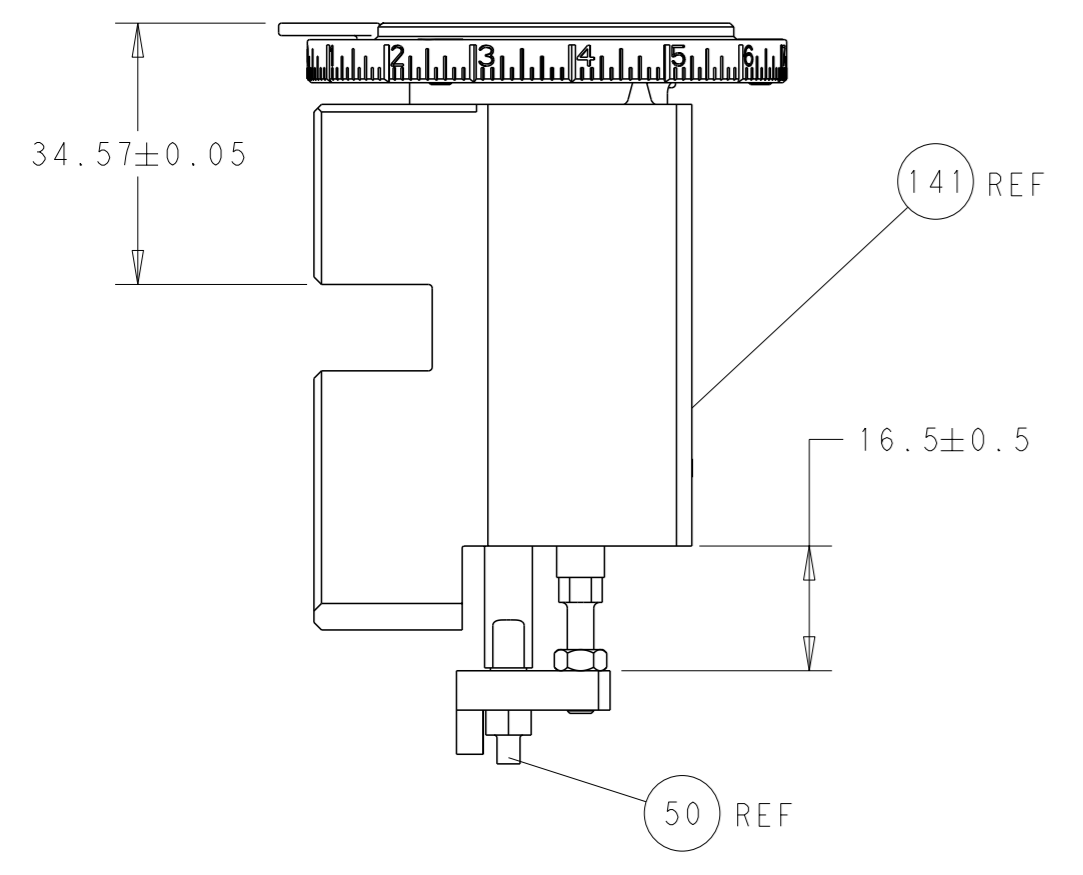

RAM AND HOLDDOWN SET-UP

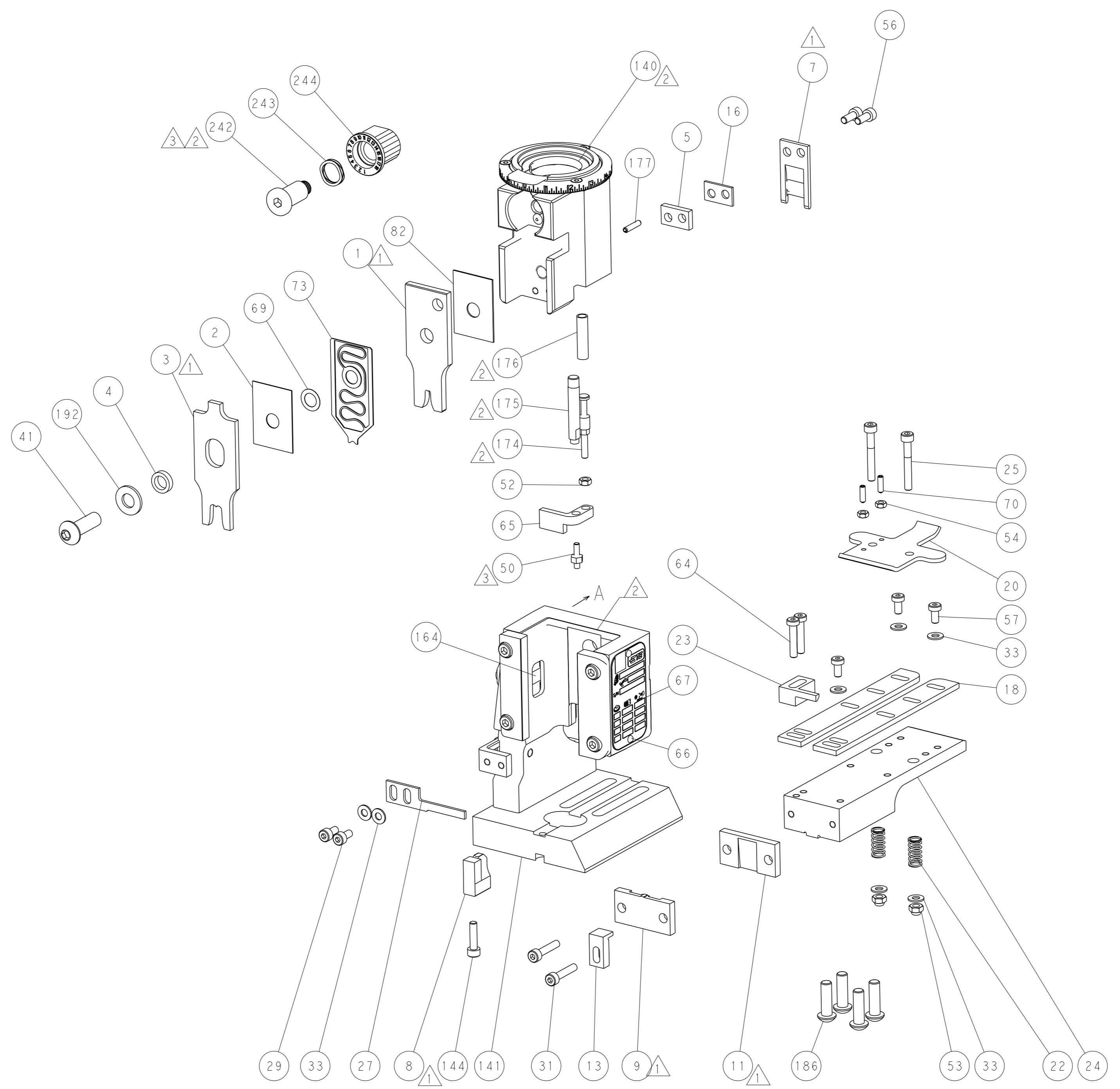

FEED TYPE

PNEUMATIC

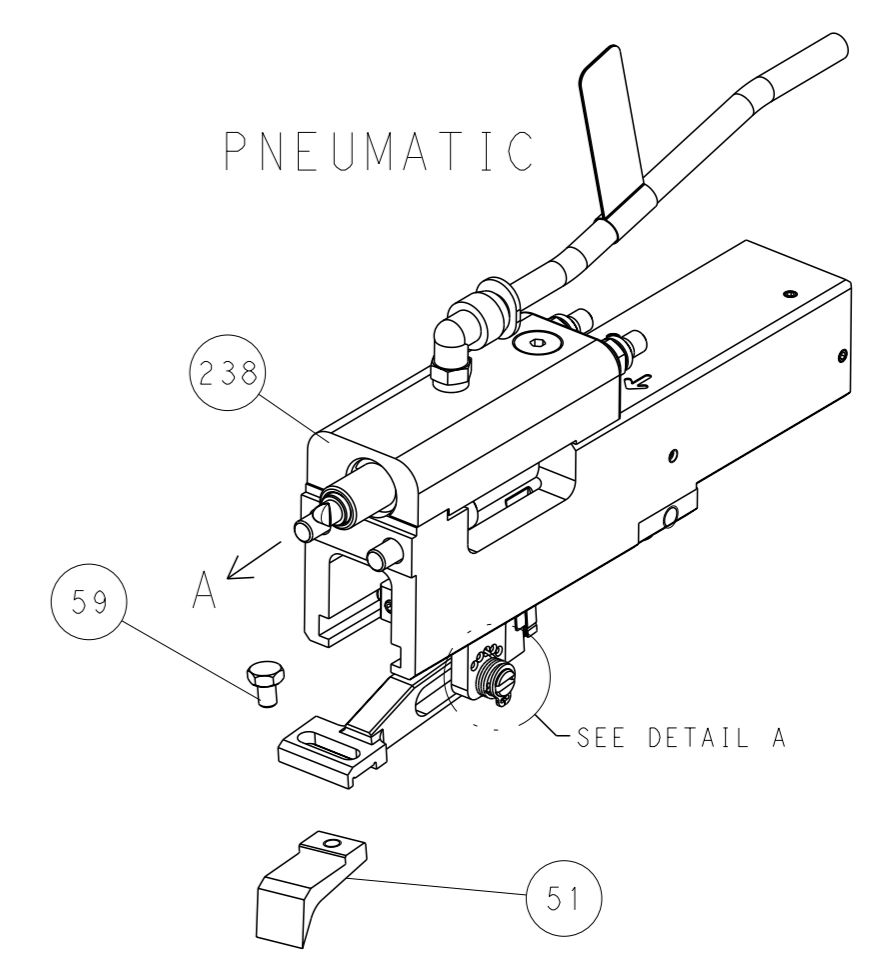

FEED SPRING SETTING POSITION

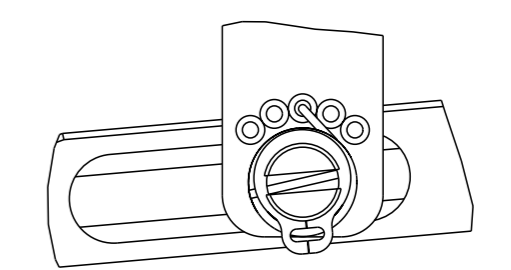

DETAIL A

CAM POSITIONS

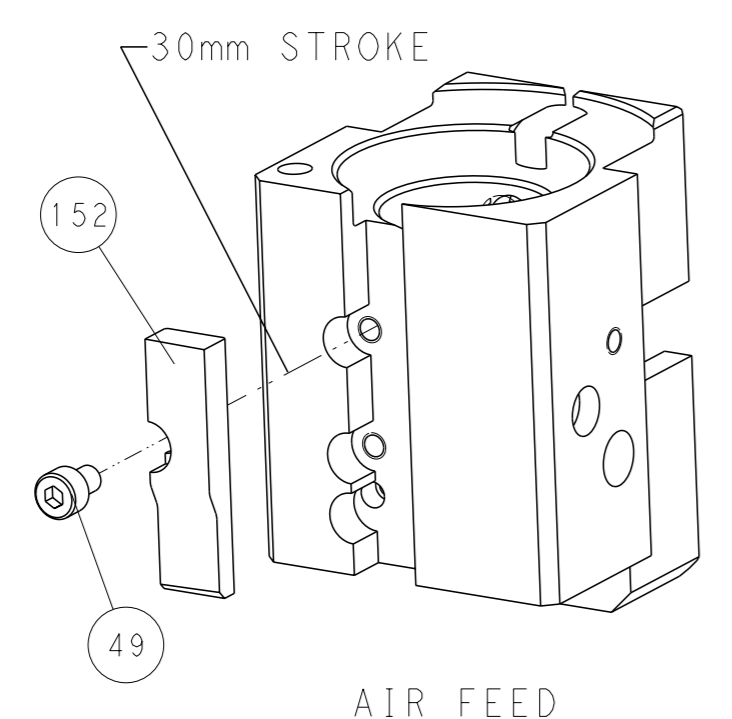

AIR FEED

PACIFIC VERSION
 Shown on sheets 3 of 4 & 4 of 4
 (Atlantic version shown on sheets 1 of 4 & 2 of 4)

DIMENSIONS: mm 		TOLERANCES UNLESS OTHERWISE SPECIFIED: 0 PLC ± 1 PLC ± 2 PLC ± 3 PLC ± 4 PLC ± ANGLES FINISH ±		OWN L. ZHANG 03FEB2012 CHK L. ZHANG 03FEB2012 APVD S. YI 03FEB2012	NAME Ocean End Feed Applicator
MATERIAL:		WEIGHT:		SIZE: A1 CAGE CODE: 00779 DRAWING NO: C=2150056	RESTRICTED TO:
Customer Accessible Production Drawing				SCALE: 1:1	SHEET 4 OF 4 REV D