

## G4 DIGITAL AC OUTPUT MODULES

### Features

- > 4000 volts optical isolation (transient)
- > Built-in LED status indicator
- > Logic levels of 5, 15, and 24 VDC
- > Removable fuse
- > Current rating: 3 amps at 45° C
- > UL Motor Load rating: 1.5 amps
- > Ability to withstand one-cycle surge of 80 amps
- > Operating temperature: -30 °C to 70 °C



G4OAC5A and G4OAC5AMA  
Modules

### DESCRIPTION

Opto 22's G4 AC output modules are used to control or switch AC loads. Each module provides up to 4000 volts of optical isolation (transient) between field outputs and the control side of the circuit, and each features zero voltage turn-on and zero current turn-off.

All AC output modules are equivalent to single-pole, single-throw, normally open contacts (Form A, SPST-NO) except the G4OAC5A5, which is equivalent to a single-pole, single-throw, normally closed contact (Form B, SPST-NC).

Each module is equipped with a 4 amp fast-blow fuse. The fuse breaking capacity is 40 amps at 250 VAC. Current should be limited to prevent the short circuit current from exceeding the rated breaking capacity of the fuse.

Typical applications for AC output modules include switching loads such as AC relays, solenoids, motor starters, heaters, lamps, and indicators.

The G4OAC5MA and the G4OAC5AMA are special modules featuring a manual-on/manual-off/automatic switch, ideal for diagnostic testing of control applications.

Part numbers ending in FM are Factory Mutual approved.

#### Compatible with Raspberry Pi

The following G4 digital AC output modules can be used with the Digital I/O Carrier Board for Raspberry Pi® (part number [OPTO-P1-40P](#)) to monitor and control industrial devices with your Raspberry Pi:

- G4OAC5
- G4OAC5A
- G4OAC5A5
- G4OAC5MA
- G4OAC5AMA

### Part Numbers

Part	Description
G4OAC5*	G4 AC Output 12–140 VAC, 5 VDC Logic
G4OAC5FM	G4 AC Output 12–140 VAC, 5 VDC Logic, Factory Mutual Approved
G4OAC5A*	G4 AC Output 24–280 VAC, 5 VDC Logic
G4OAC5AFM	G4 AC Output 24–280 VAC, 5 VDC Logic, Factory Mutual Approved
G4OAC5A5*	G4 AC Output 24–280 VAC, 5 VDC Logic NC
G4OAC5A5FM	G4 AC Output 24–280 VAC, 5 VDC Logic NC, Factory Mutual Approved
G4OAC5MA*	G4 AC Output 12–140 VAC, 5 VDC Logic With Manual/Auto Switch
G4OAC5AMA*	G4 AC Output 24–280 VAC, 5 VDC Logic With Manual/Auto Switch
G4OAC15	G4 AC Output 12–140 VAC, 15 VDC Logic
G4OAC15A	G4 AC Output 24–280 VAC, 15 VDC Logic
G4OAC24	G4 AC Output 12–140 VAC, 24 VDC Logic
G4OAC24A	G4 AC Output 24–280 VAC, 24 VDC Logic

\* Compatible with Raspberry Pi

Raspberry Pi® is a trademark of the Raspberry Pi Foundation.



## SPECIFICATIONS

	Units	G4OAC5* G4OAC5FM**	G4OAC5A* G4OAC5AFM**	G4OAC5A5* G4OAC5A5FM**	G4OAC5MA*	G4OAC5AMA*
Nominal line voltage	VAC	120	120/240	120/240	120	120/240
Output voltage range	VAC	12–140	24–280	24–280	12–140	24–280
Key feature	—	—	—	Normally closed	Diagnostic switch	Diagnostic switch
Current rating: At 45 °C ambient	A	3	3	3	3	3
At 70 °C ambient	A	2	2	2	2	2
UL Motor Load Rating	A	1.5	1.5	1.5	1.5	1.5
Isolation input-to-output (transient): 1 ms 1 minute	volts	4000 1500	4000 1500	4000 1500	4000 1500	4000 1500
Off-state leakage at nominal voltage (60 Hz)	mA <sub>RMS</sub>	5	1.25/2.5	1.25/2.5	5	1.25/2.5
Nominal logic voltage	VDC	5	5	5	5	5
Logic voltage range	VDC	4–8	4–8	4–8	4–8	4–8
Logic pickup voltage	VDC	4	4	4	4	4
Logic dropout voltage	VDC	1	1	1	1	1
Logic input current at nominal logic voltage	mA	12	12	12	12	12
Control resistance (Rc in schematic)	ohms	220	220	220	220	220
One-cycle surge	A peak	80	80	80	80	80
Turn-on time @ 60 Hz	milliseconds	≤8.3***	≤8.3***	≤8.3***	≤8.3***	≤8.3***
Turn-off time @ 60 Hz	milliseconds	≤8.3****	≤8.3****	≤8.3****	≤8.3****	≤8.3****
Peak repetitive voltage	VAC	500	500	500	500	500
Minimum load current	mA	20	20	20	20	20
Output voltage drop maximum peak	V	1.6	1.6	1.6	1.6	1.6
Operating frequency	Hz	25–65	25–65	25–65	25–65	25–65
dV/dT-off-state	V/micro-seconds	200	200	200	200	200
dV/dT-commutating	--	snubbed for 0.5 power factor load	snubbed for 0.5 power factor load	snubbed for 0.5 power factor load	snubbed for 0.5 power factor load	snubbed for 0.5 power factor load
Temperature Operating:	°C	-30 to +70	-30 to +70	-30 to +70	-30 to +70	-30 to +70
Storage:	°C	-30 to +85	-30 to +85	-30 to +85	-30 to +85	-30 to +85

\* Compatible with Raspberry Pi

\*\* Part numbers ending in FM are Factory Mutual approved.

\*\*\* One-half cycle maximum. Module turns on at the zero volt crossing of the AC sine wave.

\*\*\*\* One-half cycle maximum. Module turns off at the zero current crossing of the AC sine wave.



## SPECIFICATIONS (CONT.)

	Units	G4OAC15***	G4OAC15A***	G4OAC24***	G4OAC24A***
Nominal line voltage	VAC	120	120/240	120	120/240
Output voltage range	VAC	12–140	24–280	12–140	24–280
Key feature	—	—	—	—	—
Current rating:					
At 45 °C ambient	A	3	3	3	3
At 70 °C ambient	A	2	2	2	2
UL Motor Load Rating	A	1.5	1.5	1.5	1.5
Isolation input-to-output (transient):					
1 ms	volts	4000	4000	4000	4000
1 minute		1500	1500	1500	1500
Off-state leakage at nominal voltage (60 Hz)	mA <sub>RMS</sub>	5	1.25/2.5	5	1.25/2.5
Logic voltage range	VDC	10.5–16	10.5–16	19.5–32	19.5–32
Logic pickup voltage	VDC	10.5	10.5	19.5	19.5
Logic dropout voltage	VDC	1	1	1	1
Logic input current at nominal logic voltage	mA	15	15	18	18
Control resistance (R <sub>c</sub> in schematic)	ohms	1 K	1 K	2.2 K	2.2 K
One-cycle surge	A peak	80	80	80	80
Turn-on time @ 60 Hz	micro-seconds	≤8.3*	≤8.3*	≤8.3*	≤8.3*
Turn-off time @ 60 Hz	micro-seconds	≤8.3**	≤8.3**	≤8.3**	≤8.3**
Peak repetitive voltage	VAC	500	500	500	500
Minimum load current	mA	20	20	20	20
Output voltage drop maximum peak	V	1.6	1.6	1.6	1.6
Operating frequency	Hz	25–65	25–65	25–65	25–65
dV/dT-off-state	V/micro-second	200	200	200	200
dV/dT-commutating	--	snubbed for 0.5 power factor load	snubbed for 0.5 power factor load	snubbed for 0.5 power factor load	snubbed for 0.5 power factor load
Temperature					
Operating:	°C	-30 to +70	-30 to +70	-30 to +70	-30 to +70
Storage:	°C	-30 to +85	-30 to +85	-30 to +85	-30 to +85

\* One-half cycle maximum. Module turns on at the zero volt crossing of the AC sine wave.

\*\* One-half cycle maximum. Module turns off at the zero current crossing of the AC sine wave.

\*\*\* Not for use with Opto 22 brains.

## DIMENSIONS

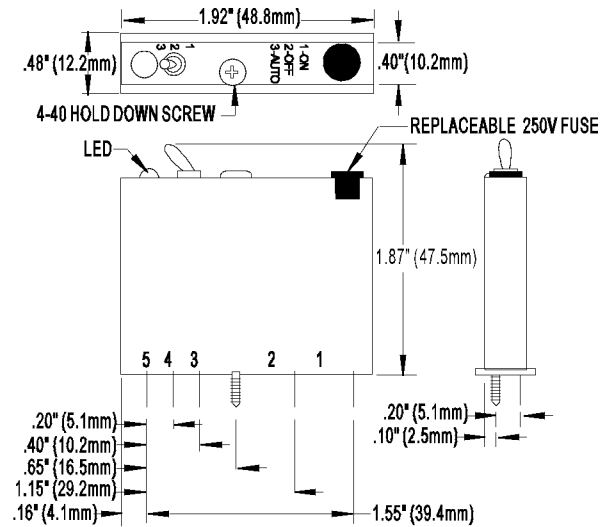
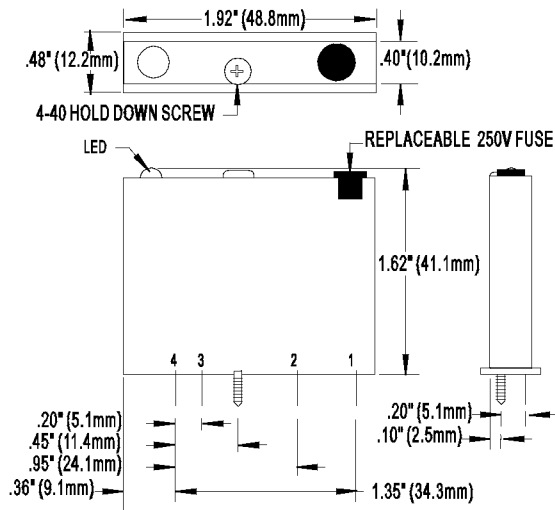

## SCHEMATICS

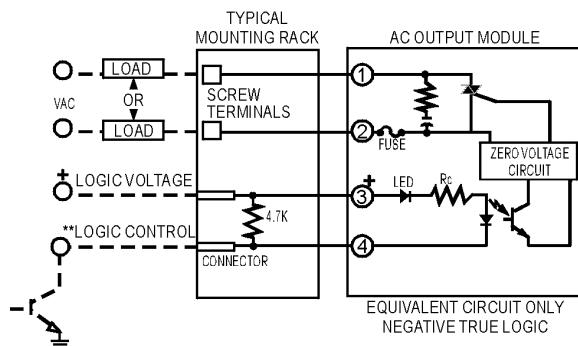

\*\*Control line is compatible with totem pole or tri-state output device.

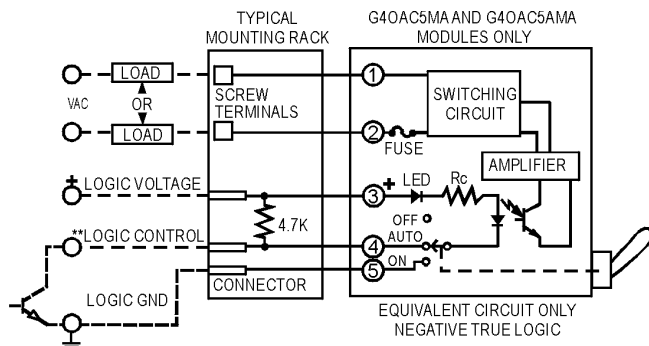

\*\*Control line is compatible with totem pole or tri-state output device.