

iMOTION2go User Manual

iMOTION™ starter kit for iMOTION™ design platform

About this document

Scope and purpose

This application note provides an overview of the evaluation board iMOTION2go including its main features, key technical data, pin assignments and mechanical dimensions.

iMOTION2go is a full motor-control system starter kit including an IMC101T-T038 controller, an inverter IPM and a brushless direct current (BLDC) motor load, which provides a ready-to-use hardware setup for using the iMOTION™ design platform, MCEDesigner and MCEWizard. It also comprises other necessary software/parameter configurations required for directly running a motor with the iMOTION™ motor-tuning tool, MCEDesigner, to evaluate all the features of the iMOTION™ design ecosystem.

The iMOTION2go starter kit was developed to support customers during their first steps designing applications with the iMOTION™ design ecosystem. It also can be used by engineers to debug their script code.

The starter kit iMOTION2go is not intended to be used for real motor-control application designs such as a home appliance and/or light industrial application field.

Intended audience

This application note is intended for all electrical engineers who are interested in evaluating Infineon iMOTION motor-control products, in particular iMOTION tools and software. The iMOTION2go evaluation board is intended to be used with a PC (plugged into the USB port of a PC) under no-load motor conditions.

Safety precautions

Table of contents



About this document.....	1
Table of contents.....	2
1 Safety precautions	3
2 Introduction	4
3 Main features.....	5
4 LED, connector and tuner	7
5 Schematics and layout.....	8
6 Getting started with iMOTION2go	11
7 Reference.....	13
Revision history.....	14

Safety precautions

1 Safety precautions

Please note the following warnings regarding hazards associated with development systems.

Table 1 Precautions

	Caution: <i>The iMOTION2GO system contains parts and assemblies sensitive to electrostatic discharge (ESD). Electrostatic control precautions are required when installing, testing, servicing or repairing the assembly. Component damage may result if ESD control procedures are not followed. If you are not familiar with electrostatic control procedures, refer to the applicable ESD protection handbooks and guidelines.</i>
	Caution: <i>Bad handling or application errors such as touching the motor winding wire, clamping the motor, bending the board, supplying an incorrect or inadequate DC supply, or excessive ambient temperatures may result in system malfunction.</i>
	Caution: <i>The iMOTION2GO system is designed for software tools learning and practicing. It is not a hardware design reference for a power load. Operating with any additional load may cause board malfunction or damage.</i>

Introduction

2 Introduction

The iMOTION2go starter kit is designed to present an easy-to-use motor drive solution based on Infineon's iMOTION™ controller and design platform. The board contains a USB interface, a DC/DC converter, an IMC controller, an IPM, and a 3-phase BLDC motor.

The features of this board are described in the design feature chapter of this document, whereas the remaining paragraphs provide information to help users to copy, modify and qualify the design for production according to their own specific requirements.

The boards provided by Infineon are only subject to MCEDesigner & MCEWizard functional testing.

This board is intended to be used under no load conditions and only for purpose of evaluating iMOTION motor control software and tools.

The block diagram of the iMOTION2go is depicted in Figure 1.

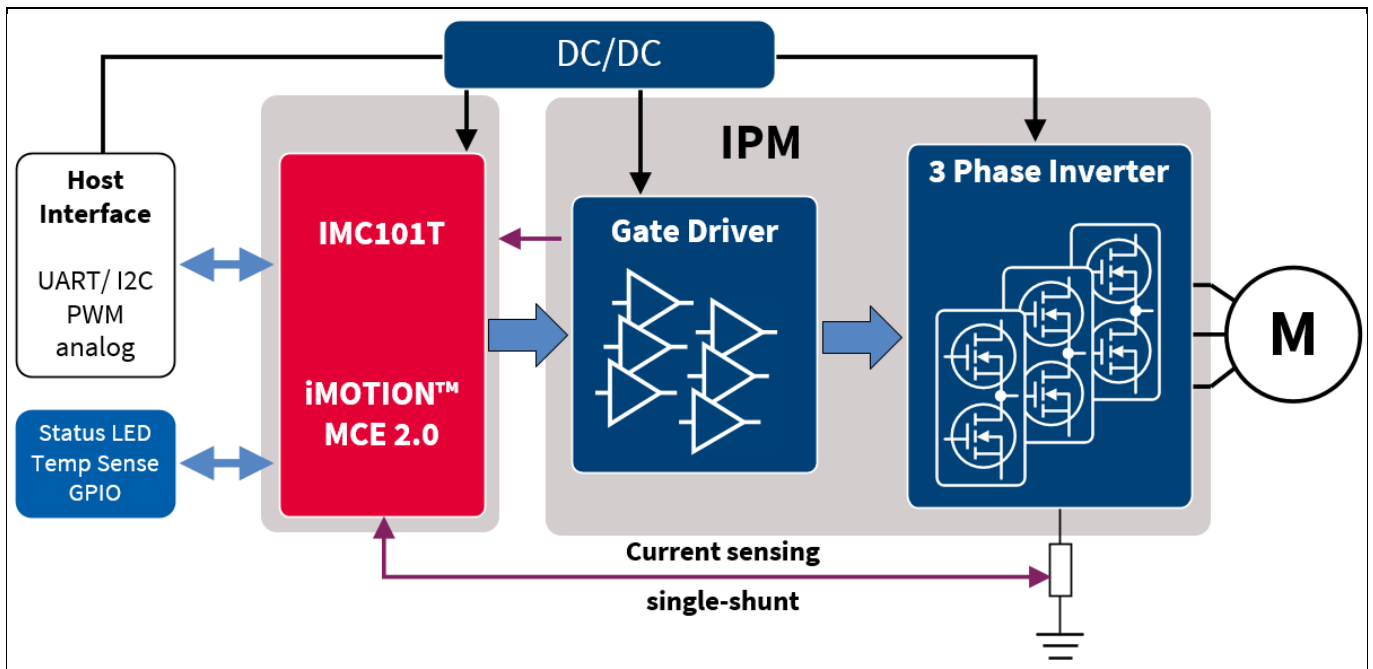

Figure 1 iMOTION2go block diagram

Main features

3 Main features

iMOTION2go starter kits are intended for learning and practicing the iMOTION™ design platform, MCEDesigner and MCEWizard. The main features of MCEWizard include:

- Creation of parameter sets for full motor control system
- Design of a script code for application adaption
- Configuration for individual digital pins and analog pins

The main features of MCEDesigner include:

- Programming and updating of code/parameters to controller IC
- Controlling, monitoring and tuning of the motor drive system
- Setup of a function that commands speed profiles for testing of specific application

The main characteristics of the demo board include:

- Entire motor control system
- Powered by PCB USB output
- No hardware setup needed
- Algorithm integrated in IMC101 iMOTION motor controller
- System parameters pre-configured for instantaneous start of the motor
- Pre-loaded with script that runs the varying speed demo
- Free software tools for system monitoring and tuning
- On-board-debugger chip for communication and programming of IMC101T chip

Table 1 lists all the important specifications of the evaluation board iMOTION2go.

Table 1 iMOTION2go specifications

Parameters	Values	Conditions
Input voltage	5 V _{rms}	USB socket
Motor phase current	50 mA _{rms}	
Maximum DC bus voltage	16 V	generated on board
Minimum DC bus voltage	14 V	
Shunt resistor RS1	1000 mΩ	Single shunt configuration
IPM power supply	15V±5%, max. 50 mA	For inverter IPM
Controller power supply	3.3V±2%, max. 20 mA	For IMC101T
PCB material	FR4, 2 layers, 2 oz copper	
PCB dimensions	62 mm x 22 mm	
Ambient temperature	From 0 to 60°C	

Main features

Figure 2 points out the functional parts of the iMOTION2go demo board.

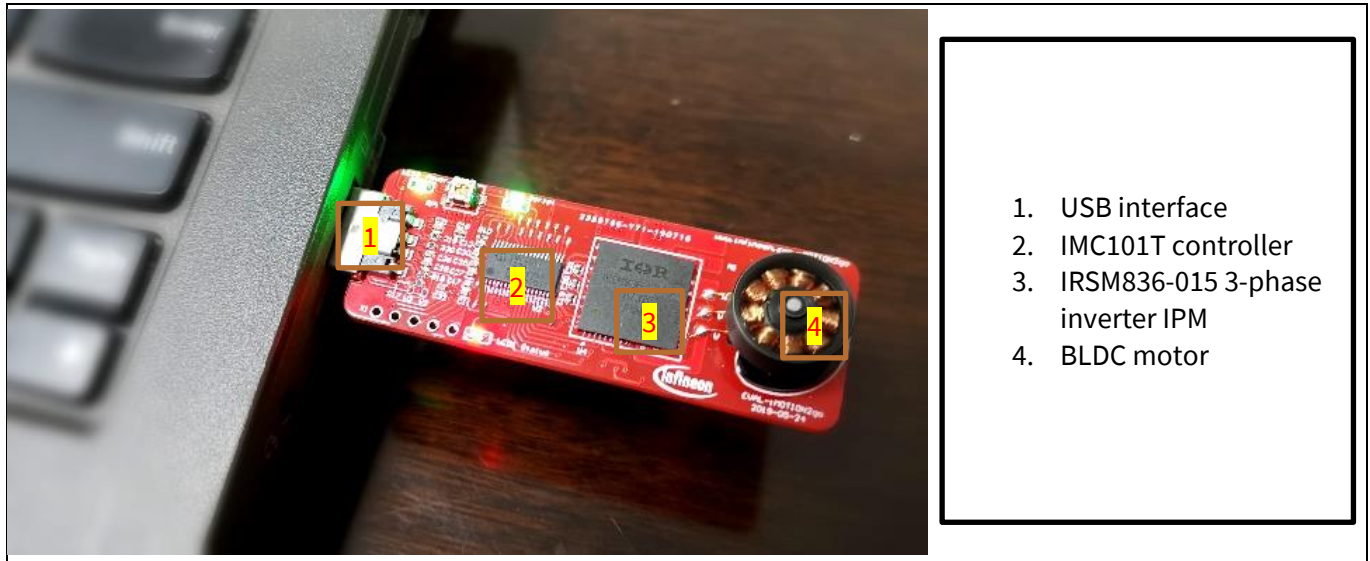

Figure 2 Functional part of the iMOTION2go

LED, connector and tuner

4 LED, connector and tuner

Table 2 Description of on-board LED, connector and tuner

Name	Description
LED1	System <i>status</i>
LED2	<i>Script</i> running status
LED3	<i>Power</i> supply monitor
RP1	Motor speed reference(tuned by a screwdriver)
X1	Programming port

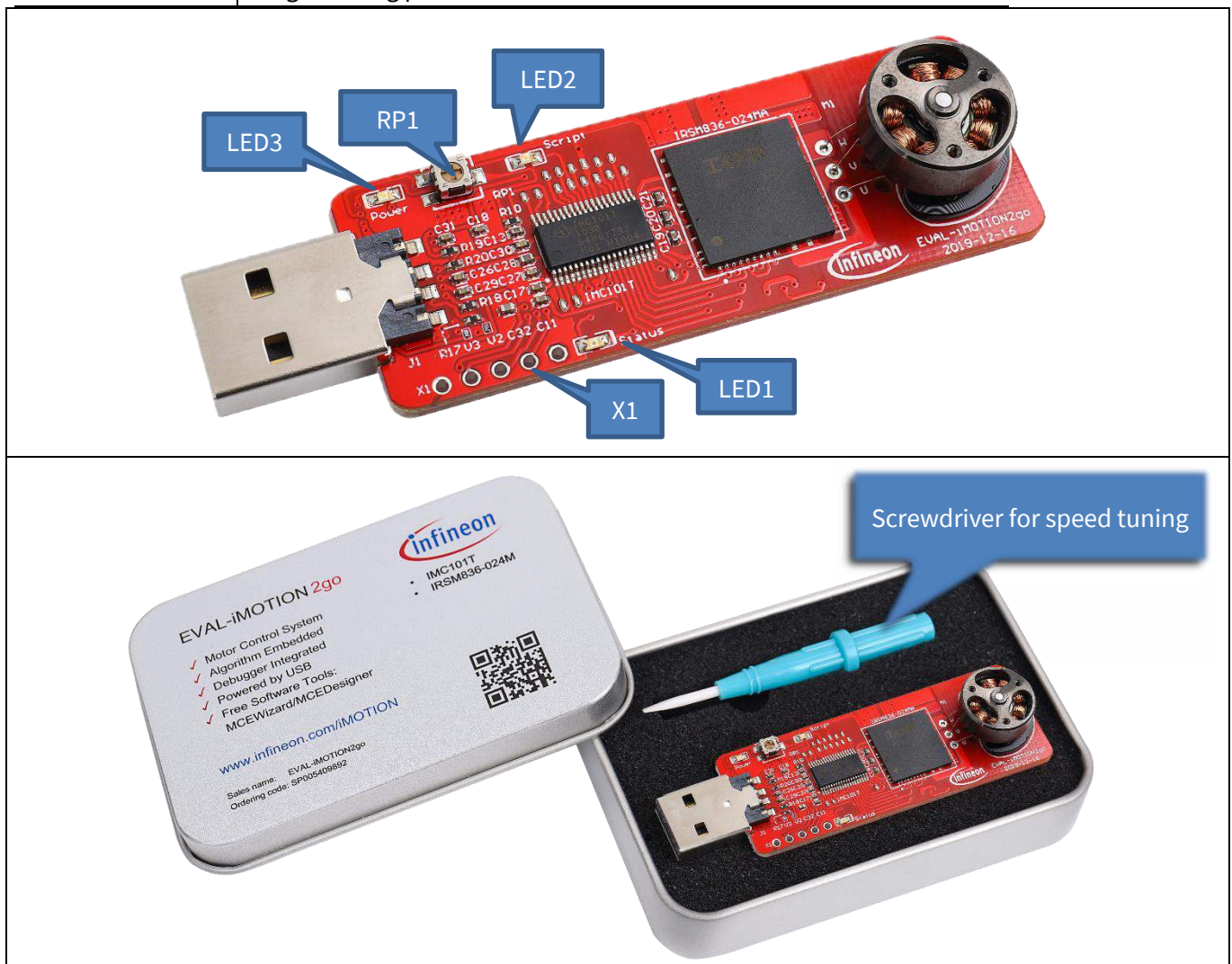

Figure 3 LED, connector and tuner

Schematics and layout

5 Schematics and layout

Given its pure demonstration purpose, with focus on tools, this board is not intended to be used as a reference for hardware design, the schematics and layout are included in this chapter for better understanding system. In Figure 4, Figure 5, Figure 6 and Figure 7, an overview of the different parts of the iMOTION2go are presented.

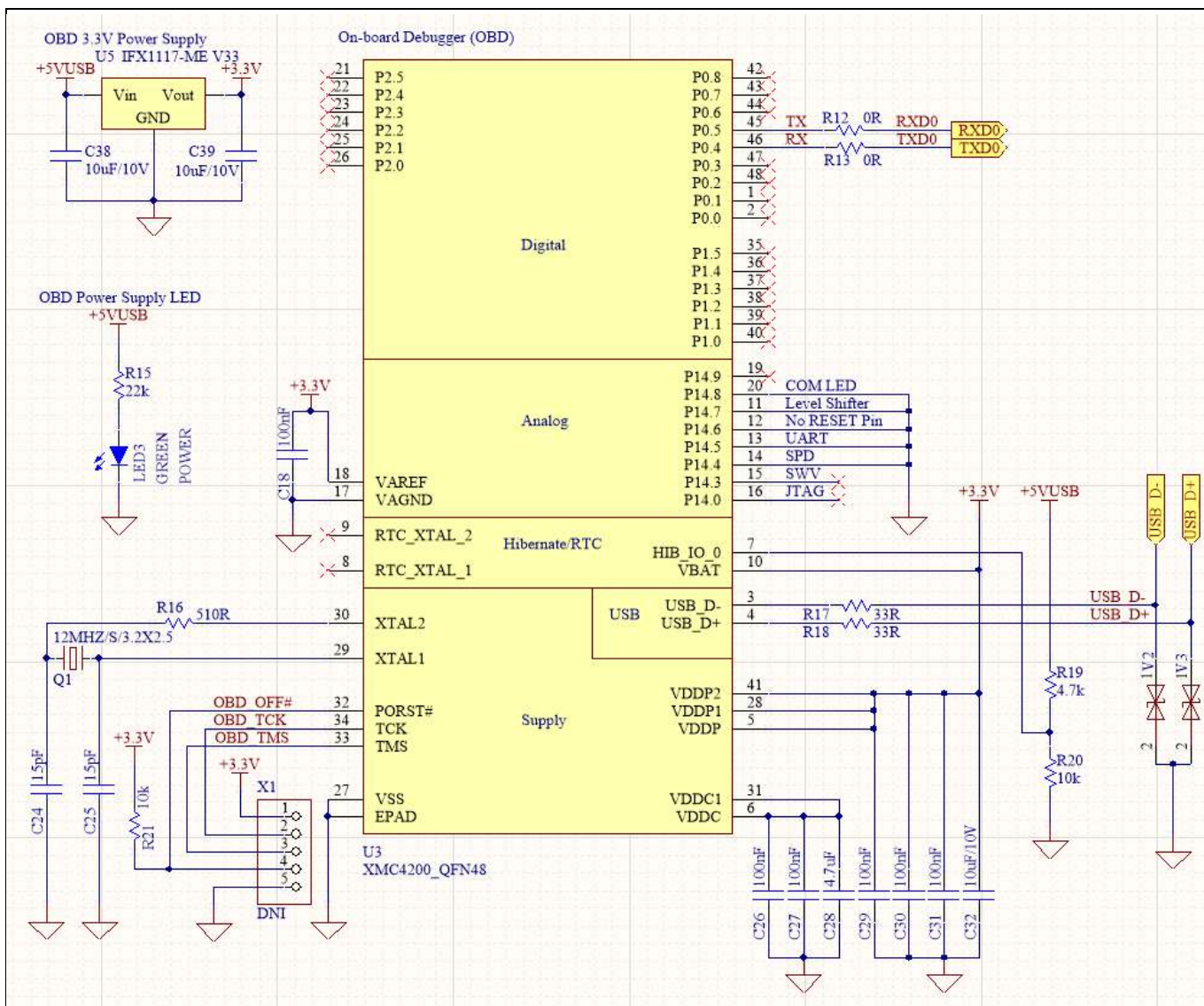

Figure 4 On-board debugger

Schematics and layout

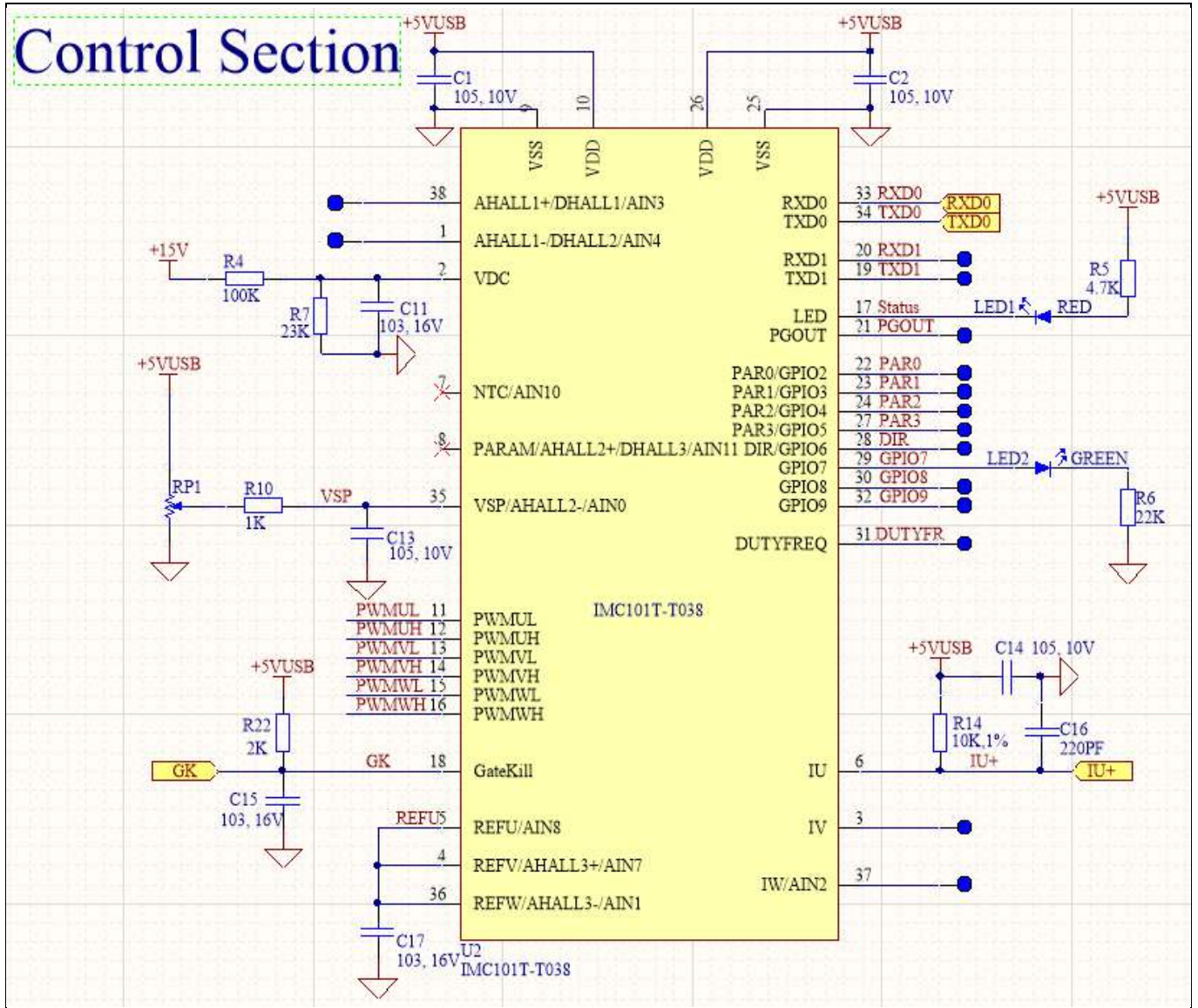

Figure 5 Controller

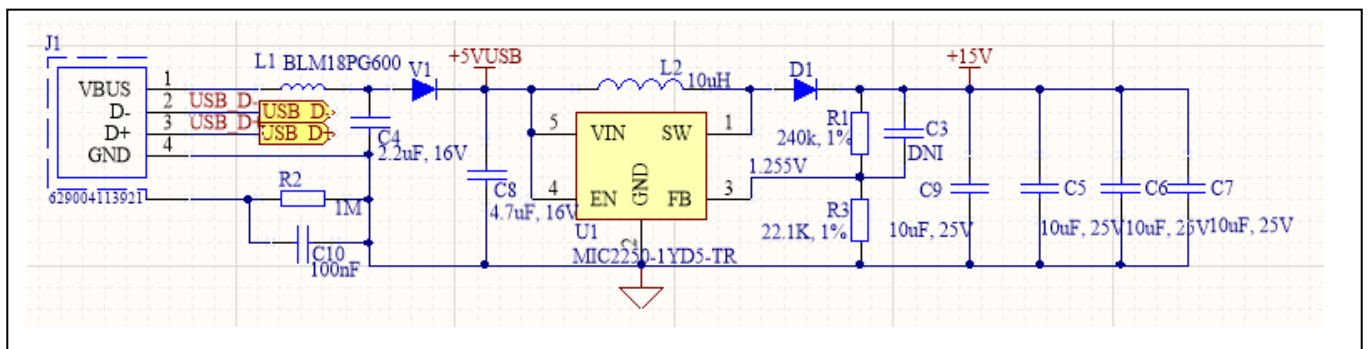

Figure 6 Power supplies

Schematics and layout

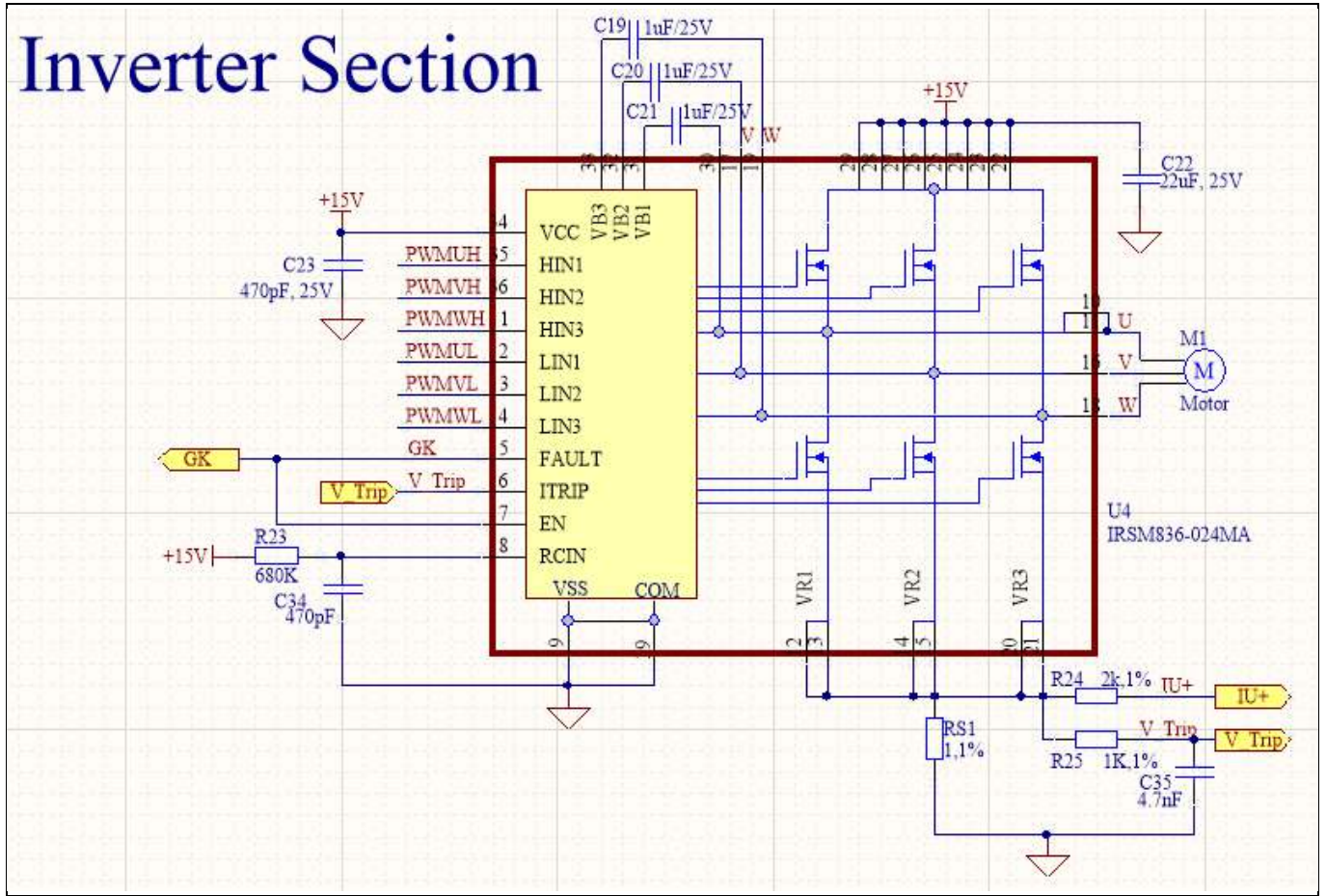

Figure 7 Power inverter

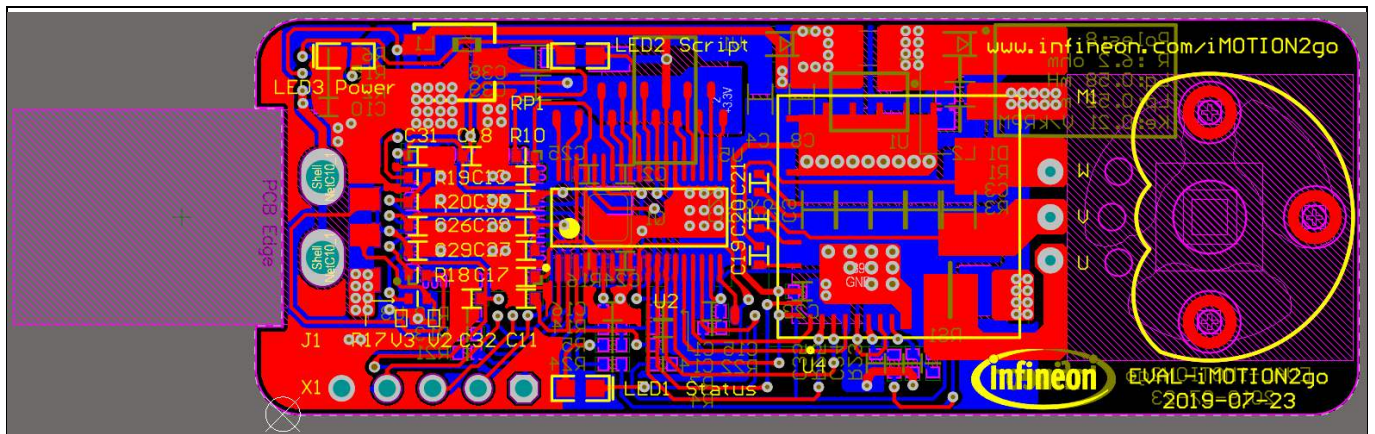

Figure 8 Top assembly print of the iMOTION2go evaluation board

Getting started with iMOTION2go

6 Getting started with iMOTION2go

The iMOTION2go is shipped with all software and parameters programmed. **The motor on board will automatically run by an embedded demo code once it is plugged into your computer USB socket, so don't touch the motor when you plug the board to the slot.** The motor speed can be tuned via the RP1 with a screwdriver. All files which are used for setting up this demo are available as .zip package at www.infineon.com/imotion2go/software.

File list in this package:

1. IMC101T-T038_A_V1.02.20.ldf-----MCE firmware code
2. iMOTION2go190904-Neweco2_Script.ldf-----script code
3. iMOTION2go190904-Neweco2_IMC101T.map-----variable list in script
4. Test190904-Neweco2.txt-----parameter file
5. IMC101T_V1.02.20_iMOTION2go.irc-----MCEDesigner tuning file

The iMOTION™ software tools MCEDesigner and MCEWizard are required in order to study the design platform. These tools are available for download via the Infineon website (<http://www.infineon.com/imotion-software>). All supported tool and software versions are listed there. Please visit this page periodically to check for tool/software updates.

Once the tools are installed, you can use them to check waveform/tune parameters/function control of this board by. When the board is plugged into the board in the USB slot, the motor will automatically run, it is controlled by the demo script code. To switch to be controlled by MCEDesigner, these steps are to be followed:

1. Start MCEDesigner and open the tuning file, IMC101T_V1.02.20_iMOTION2go.irc by clicking “File” > “Open”.

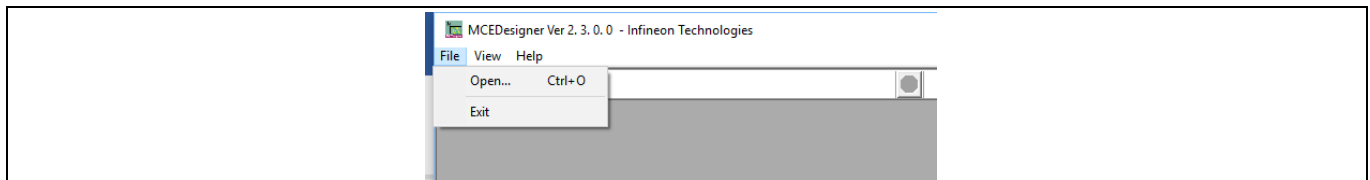

Figure 9 Open the tuning file(.irc)

2. MCEDesigner should automatically connect to the iMOTION2go evaluation board using default COM port (indicated by green circle next to “COMx Up” status in the bottom frame of the MCEDesigner GUI). If it cannot establish the connection, change COM port by doing the following: click on the “System” window and then click on “Preferences” > “Connection” > “Connect using”, and choose one of the other available COM ports from the drop-down list.

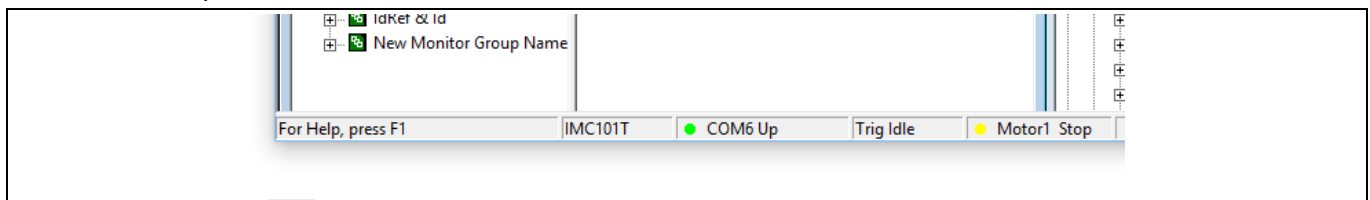

Figure 10 Connection to the board

3. In the “Motor” window, you can set register 'Script_Command' to '1' or '0' to switch the control by embedded script code or by MCEDesigner. Before changing this setting user needs to stop the motor if it is running (click on red traffic light icon) and afterwards he needs to start it again (green traffic light icon) with new setting active.

Getting started with iMOTION2go

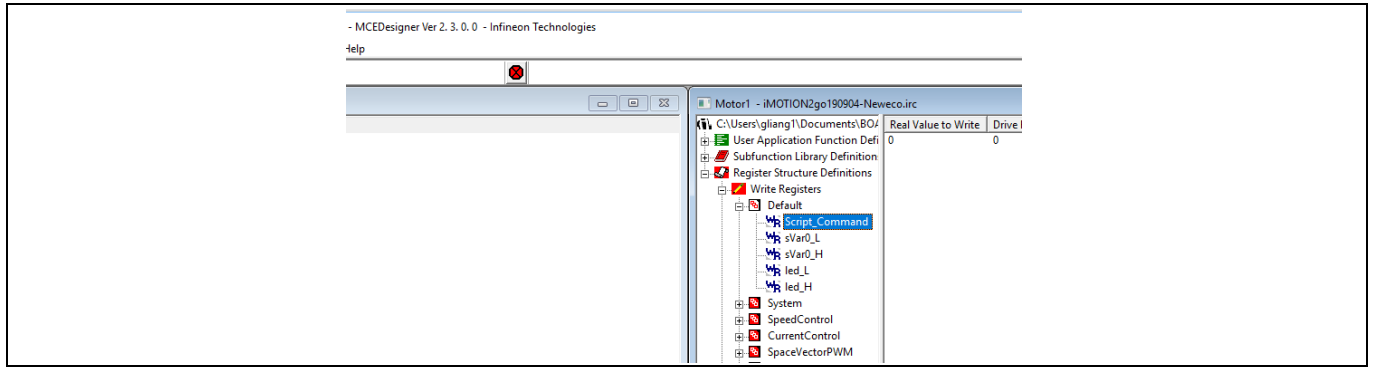

Figure 11 Demonstration script disable/enable

4. Refer to MCEDesigner Application Guide.pdf and MCEWizard User Guide.pdf for more information.

*Note: For more information about the iMOTION™ design platform, please visit our website:
<https://www.infineon.com/imotion>*

Reference

7 Reference

- [1] Infineon-IMC100-DS-v01_04-EN.pdf
- [2] Infineon-MCESW-RM-UserManual-v01_02-EN.pdf
- [3] MCEWizard_V2.0.1.1 User Guide.pdf
- [4] MCEDesigner_V2.0.1.1 Application Guide.pdf

Notice:

Infineon's product registration is online now. Register your board and download more information.

Follow three easy steps to register:

1. Go to www.infineon.com/ login to myinfineon
2. Click on "Product Registration"
3. Choose your board and enter board series number; download the related information package

Revision history

Document version	Date of release	Description of changes
1.0	2020-04-02	First Release
1.1	2020-04-10	Some description modification

Trademarks

All referenced product or service names and trademarks are the property of their respective owners.

Edition 2019-06-18

**Published by Infineon Technologies AG
81726 Munich, Germany**

**© 2019 Infineon Technologies AG All
Rights Reserved.**

**Do you have a question about any aspect
of this document?**

Email: erratum@infineon.com

Document reference

IFX-vqf1553180223116

IMPORTANT NOTICE

The information given in this document shall in no event be regarded as a guarantee of conditions or characteristics ("Beschaffenheitsgarantie").

With respect to any examples, hints or any typical values stated herein and/or any information regarding the application of the product, Infineon Technologies hereby disclaims any and all warranties and liabilities of any kind, including without limitation warranties of non-infringement of intellectual property rights of any third party.

In addition, any information given in this document is subject to customer's compliance with its obligations stated in this document and any applicable legal requirements, norms and standards concerning customer's products and any use of the product of Infineon Technologies in customer's applications.

The data contained in this document is exclusively intended for technically trained staff. It is the responsibility of customer's technical departments to evaluate the suitability of the product for the intended application and the completeness of the product information given in this document with respect to such application.

WARNINGS

Due to technical requirements products may contain dangerous substances. For information on the types in question please contact your nearest Infineon Technologies office.

Except as otherwise explicitly approved by Infineon Technologies in a written document signed by authorized representatives of Infineon Technologies, Infineon Technologies' products may not be used in any applications where a failure of the product or any consequences of the use thereof can reasonably be expected to result in personal injury